

ANNUAL 2020

# title

book



GENERAL TABLE OF CONTENTS **INDICE GENERALE**  
 hauptinhaltsverzeichnis - index général - índice general - содержание



<b>Indice alfabetico</b> <span style="float: right;">2</span>	<b>Concrete Effect</b> <span style="float: right;">130</span>
alphabetical index / alphabetisches Verzeichnis / index alphabétique / índice alfabético / алфавитный указатель	gres effetto cemento / concrete effect stoneware / Beton-Cotto-Optik Feinsteinzeug / grès effet ciment cotto / gres efecto cotto cemento / керамогранит с эффектом неглазурованной керамики-цемента
<b>Indice per effetto</b> <span style="float: right;">3</span>	<b>Wood Effect</b> <span style="float: right;">196</span>
index by look / verzeichnis nach optik / índice por efectos / index par effet / указатель по эффектам	gres effetto legno / wood effect stoneware / Holzoptik Feinsteinzeug / grès effet bois / gres de efecto madera / керамогранит с эффектом дерева
<b>Indice per formati</b> <span style="float: right;">4</span>	<b>XT20</b> <span style="float: right;">282</span>
index of sizes / inhaltsübersicht formate / index des formats / índice de formatos / перечень форматов	extra spessore 20mm / extra thickness 20 mm / Überstärke 20mm / épaisseur extra 20 mm / grosor extra de 20 mm / увеличенная толщина
<b>Indice per superfici</b> <span style="float: right;">6</span>	<b>Small Sizes</b> <span style="float: right;">360</span>
index of surfaces / verzeichnis oberfläche / index finitions / índice de superficies / указатель поверхностей	piccoli formati / kleine formate / petits formats / formatos pequeños / маленькие форматы
<b>Company profile</b> <span style="float: right;">8</span>	<b>Wall Tiles</b> <span style="float: right;">396</span>
<b>Maiora</b> <span style="float: right;">16</span>	rivestimenti / wandfliesen / revêtements de mur / revestimientos / настенная плитка
lastre in gres porcellanato / porcelain stoneware slabs / Feinsteinzeugplatten / dalles en grès cérame / placas de gres porcelánico / плиты из керамогранита	<b>Homeline - Floor</b> <span style="float: right;">522</span>
<b>Marble Effect</b> <span style="float: right;">40</span>	porcelain stoneware / feinstezeug / grès cérame / gres porcelánico / керамогранит
gres effetto marmo / marble effect porcelain stoneware / Feinsteinzeug in Marmor-Optik / grès cérame effet marbre / gres porcelánico efecto mármol / керамогранит с эффектом мрамор	<b>Homeline - Wall</b> <span style="float: right;">552</span>
<b>Stone Effect</b> <span style="float: right;">62</span>	Rivestimenti / wall tiles / wandfliesen / revêtements de mur / revestimientos / настенная плитка
gres effetto pietra / stone effect stoneware / Feinsteinzeug in Natursteinoptik / grès effet pierre / gres efecto piedra / керамогранит под камень	<b>Appendice</b> <span style="float: right;">584</span>
	appendix / anhang / appendice / арéndice / приложение

Abitare	366	Maiora	18	Studio	180
A_Mano	370	Off	480	Tactile	420
Bistrot	42, 440	Ottocento	374	Tempera	472
Boom	156	Patina	148	Terracruda	432
Brass	568	Patina XT20	348	TexCem	454
Brick Glossy	378	Re_Solution	142	Touch	382
Calce	384	Realstone_Cardoso	92	Trama	510
Candy	554	Realstone_Cardoso XT20	306	Unitech	392
Casablanca	532, 570	Realstone_Jerusalem	98	Woodchalet	250
Cocciopesto	410	Realstone_Jerusalem XT20	310	Woodchoice	280
Colours	574	Realstone_Quarzite	104	Woodclass	264
Concept	170	Realstone_Quarzite XT20	314	Woodclassic	234
Concept XT20	356	Realstone_Lunar	64	Woodcomfort	258
Contrasti	362	Realstone_Lunar XT20	284	Woodcraft	272
Craft	576	Realstone_Navigli	70	Woodessence	276
Creek	524, 558	Realstone_Navigli XT20	288	Woodglam	278
Eden	386	Realstone_PietrAntica	74	Woodlike	262
Emilia	548	Realstone_PietrAntica XT20	292	Woodliving	206
Energy	578	Realstone_Rain	86	Woodliving XT20	334
Epoca	186	Realstone_Rain XT20	302	Woodmania	214
Escape	546	Realstone_Slate	80	Woodmania XT20	344
Fantasy	518	Realstone_Slate XT20	298	Woodpassion	268
Feel	580	Replace	528, 564	Woodplace	226
Flex	484	Resina	398	Woodreal	238
Focus	582	Rewind	162, 502	Woodsense	198
Fornace	390	Rewind XT20	352	Woodsense XT20	326
Frame	490	Ritual	446	Woodshape	242
Freestyle	498	Rock Ground	124	Woodside	218
Freetime	547	Season	538	Woodsoft	222
Galassia	550	Sound	544	Woodspace	202
Grace	560	Stone	128	Woodspace XT20	330
Harmony	254	Stoneway_Ardesia	108	Woodspirit	230
Imperiale	56, 462	Stoneway_Ardesia XT20	318	Woodstory	246
Ironstone	132	Stoneway_Barge Antica	114	Woodtale	210
Jazz	192	Stoneway_Barge Antica XT20	322	Woodtale XT20	338
Land	562	Stoneway_Porfido	120		
Life	536	Stoneway_Porfido XT20	324		



<b>Maiora</b>		Woodshape	242	32,5X97,7	
Maiora_Marble Effect	20	Woodstory	246	Ritual	Slim 6/8 mm 446
Maiora_Concrete Effect	32	Woodchalet	250	TexCem	Slim 6/8 mm 454
<b>Marble Effect</b>		Harmony	254		
Bistrot	42, 440	Woodcomfort	258	30x90	
Imperiale	56, 462	Woodlike	262	Tempera	472
<b>Stone Effect</b>		Woodclass	264	Imperiale	462
Realstone_Lunar	64	Woodpassion	268	Off	480
Realstone_Navigli	70	Woodcraft	272		
Realstone_PietrAntica	74	Woodessence	276	25X76	
Realstone_Slate	80	Woodglam	278	Flex	484
Realstone_Rain	86	Woodchoice	280	Frame	490
Realstone_Cardoso	92	<b>XT20</b>		Freestyle	498
Realstone_Jerusalem	98	Realstone_Lunar XT20	284	Rewind	502
Realstone_Quarzite	104	Realstone_Navigli XT20	288	Trama	510
Stoneway_Ardesia	108	Realstone_PietrAntica XT20	292		
Stoneway_Barge Antica	114	Realstone_Slate XT20	298	30X60	
Stoneway_Porfido	120	Realstone_Rain XT20	302	Fantasy	Slim 6/8 mm 518
Rock Ground	124	Realstone_Cardoso XT20	306	<b>Home Line - Floor</b>	
Stone	128	Realstone_Jerusalem XT20	310	Creek	524
<b>Concrete Effect</b>		Realstone_Quarzite XT20	314	Replace	528
Ironstone	132	Stoneway_Ardesia XT20	318	Casablanca	532
Re_Solution	142	Stoneway_Barge Antica XT20	322	Life	536
Patina	148	Stoneway_Porfido XT20	324	Season	538
Boom	156	Woodsense XT20	326	Sound	544
Rewind	162, 502	Woodspace XT20	330	Escape	546
Concept	170	Woodliving XT20	334	Freetime	547
Studio	180	Woodtale XT20	338	Emilia	548
Epoca	186	Woodmania XT20	344	Galassia	High Performance 550
Jazz	192	Patina XT20	348	<b>Home Line - Wall</b>	
Resina Slim 6/8 mm - wall tiles	398	Rewind XT20	352	20X50	
Cocciopesto Slim 6/8 mm - wall tiles	410	Concept XT20	356	Candy	554
Tactile Slim 6/8 mm - wall tiles	420	<b>Small Sizes</b>		Creek	558
Terracruda Slim 6/8 mm - wall tiles	432	Contrasti	362	Grace	560
Ritual Slim 6/8 mm - wall tiles	446	Abitare	366	Land	562
TexCem Slim 6/8 mm - wall tiles	454	A_Mano	370	Replace	564
Flex wall tiles	484	Ottocento	374		
<b>Wood Effect</b>		Brick Glossy	378	25X38	
Woodsense	198	Touch	382	Brass	568
Woodspace	202	Calce	384	Casablanca	570
Woodliving	206	Eden	386	Colours	574
Woodtale	210	Fornace	390	Craft	576
Woodmania	214	Unitech	392	Energy	578
Woodside	218	<b>Wall Tiles</b>		Feel	580
Woodsoft	222	40X120		Focus	582
Woodplace	226	Resina Slim 6/8 mm	398		
Woodspirit	230	Cocciopesto Slim 6/8 mm	410		
Woodclassic	234	Tactile Slim 6/8 mm	420		
Woodreal	238	Terracruda Slim 6/8 mm	432		
		Bistrot Slim 6/8 mm	440		

INDEX OF SIZES **INDICE PER FORMATI**

inhaltsübersicht formate - index des formats - índice de formatos - перечень форматов

<b>120X278</b>		<b>30X120</b>	
Maiora	18	Concept	170
		Woodliving	206
<b>120X240</b>		Woodside	218
Maiora	18	Woodtale	210
<b>120X120</b>		<b>20X120</b>	
Maiora	18	Woodliving	206
Patina	148	Woodmania	214
Realstone_Lunar	64	Woodplace	226
Realstone_Rain	86	Woodsense	198
<b>75X150</b>		Woodside	218
Bistrot	42	Woodsoft	222
Boom	156	Woodspace	202
Ironstone	132	Woodspirit	230
Patina	148	Woodtale	210
Re_Solution	142	<b>15X120</b>	
Realstone_Lunar	64	Woodliving	206
Realstone_Navigli	70	Woodside	218
Realstone_Rain	86	Woodtale	210
Realstone_Slate	80	<b>58X116</b>	
<b>25X150</b>		Imperiale	56
Woodsense	198	<b>50X100</b>	
Woodspace	202	Realstone_Cardoso XT20	306
<b>19X150</b>		Realstone_Jerusalem XT20	310
Woodsense	198	Realstone_Lunar XT20	284
<b>60X120</b>		Realstone_Quarzite XT20	314
Concept	170	Realstone_Rain XT20	302
Creek	524	Realstone_Slate XT20	298
Imperiale	56	<b>13X100</b>	
Re_Solution	142	Woodclassic	234
Realstone_Cardoso	92	Woodreal	238
Realstone_Jerusalem	98	<b>10X100</b>	
Realstone_Lunar	64	Woodclassic	234
Realstone_Navigli XT20	288	Woodreal	238
Realstone_PietrAntica	74	<b>90X90</b>	
Realstone_PietrAntica XT20	292	Rewind	162
Realstone_Quarzite	104	<b>30X90</b>	
Replace	528	Imperiale	462
Rewind	162	Off	480
Studio	180	Tempera	472
<b>40X120</b>		<b>15X90</b>	
Bistrot	440	Harmony	254
Cocciopesto	410	Woodchalet	250
Resina	398	Woodcomfort	258
Tactile	420	Woodlike	262
Terracruda	432	Woodpassion	268
Woodliving XT20	334	Woodshape	242
Woodmania XT20	344	Woodstory	246
Woodsense XT20	326		
Woodspace XT20	330		
Woodtale XT20	338		

<b>14,5X90</b>		<b>80X80</b>	
Woodclass	264	Patina XT20	348
Woodpassion	268	Realstone_Navigli XT20	288
		Realstone_Slate XT20	298
<b>75X75</b>		<b>58X58</b>	
Bistrot	42	Imperiale	56
Boom	156	<b>32,5X97,7</b>	
Concept	170	Ritual	446
Ironstone	132	TexCem	454
Patina	148	<b>25X76</b>	
Re_Solution	142	Flex	484
Realstone_Cardoso	92	Frame	490
Realstone_Jerusalem	98	Freestyle	498
Realstone_Lunar	64	Rewind	502
Realstone_Navigli	70	Trama	510
Realstone_Rain	86	<b>25X38</b>	
Realstone_Slate	80	Brass	568
Rewind	162	Casablanca	570
Studio	180	Colours	574
<b>37,5X75</b>		Craft	576
Concept	170	Energy	578
<b>60X60</b>		Feel	580
Bistrot	42	Focus	582
Boom	156	<b>45X45</b>	
Casablanca	532	Casablanca	532
Concept	170	Concept	170
Concept XT20	356	Creek	524
Creek	524	Life	536
Epoca	186	Replace	528
Imperiale	56	Rewind	162
Ironstone	132	Season	538
Jazz	192	Sound	544
Patina	148	<b>30X60</b>	
Re_Solution	142	Bistrot	42
Realstone_Cardoso	92	Boom	156
Realstone_Jerusalem	98	Casablanca	532
Realstone_Lunar	64	Concept	170
Realstone_Navigli	70	Creek	524
Realstone_PietrAntica	74	Fantasy	518
Realstone_Quarzite	104	Ironstone	132
Realstone_Rain	86	Jazz	192
Realstone_Slate	80	Patina	148
Replace	528	Re_Solution	142
Rewind	162	Realstone_Cardoso	92
Rewind XT20	352	Realstone_Jerusalem	98
Season	538	Realstone_Lunar	64
Sound	544	Realstone_Navigli	70
Stoneway_Ardesia	108	Realstone_PietrAntica	74
Stoneway_Ardesia XT20	318	Realstone_Quarzite	104
		Realstone_Rain	86
		Realstone_Slate	80
		Replace	528
		Rewind	162
		Rewind XT20	352
		Season	538
		Sound	544
		Stoneway_Ardesia	108
		Stoneway_Ardesia XT20	318

Stoneway_Barge Antica	114	Realstone_Quarzite	104
Stoneway_Barge Antica XT20	322	Realstone_Rain	86
Stoneway_Porfido XT20	324	Realstone_Slate	80
Studio	180	Replace	528
Woodsense XT20	326	Rewind	162
Woodtale XT20	338	Season	538
		Sound	544
		Stone	128
		Stoneway_Ardesia	108
		Stoneway_Barge Antica	114
		Stoneway_Porfido	120
		Studio	180
		<b>33,3X33,3</b>	
		Casablanca	532
		Life	536
		Season	538
		Sound	544
		<b>30X30</b>	
		Emilia	548
		Epoca	186
		Galassia	550
		Stone	128
		Stoneway_Ardesia	108
		Stoneway_Porfido	120
		<b>21x18,2</b>	
		Bistrot	42
		Eden	386
		Epoca	186
		Rewind	162
		<b>20X50</b>	
		Candy	554
		Creek	558
		Grace	560
		Land	562
		Replace	564
		<b>20X40</b>	
		Rock Ground	124
		Stoneway_Ardesia	108
		Stoneway_Barge Antica	114
		<b>20X20</b>	
		Abitare	366
		A_Mano	370
		Contrasti	362
		Galassia	550
		Ottocento	374
		Rock Ground	124
		Stoneway_Ardesia	108
		Stoneway_Barge Antica	114
		Unitech	392

<b>15X60</b>		<b>15X60</b>	
Concept	170	Concept	170
Stoneway_Barge Antica	114	Stoneway_Barge Antica	114
<b>15X30</b>		<b>15X15</b>	
Epoca	186	Emilia	548
Stoneway_Porfido	120	Epoca	186
<b>12,5X50</b>		Stoneway_Porfido	120
Escape	546	<b>11x54</b>	
Freetime	547	Woodchoice	280
<b>10X70</b>		<b>10X30</b>	
Woodcraft	272	Brick Glossy	378
Woodessence	276	Touch	382
Woodglam	278	Unitech	392
<b>10X30</b>		<b>10X10</b>	
Brick Glossy	378	Concept	170
Touch	382	Season	538
Unitech	392	Stone	128
<b>7X28</b>		Unitech	392
Bistrot	42	<b>15X60</b>	
Calce	384	Concept	170
Eden	386	Season	538
Fornace	390	Stone	128
Rewind	162	Unitech	392

INDEX OF SIZES **INDICE PER SUPERFICI**

index of surfaces - verzeichnis oberfläche - index finitions - índice de superficies - указатель поверхностей

**In&Out**

Bistrot	42
Boom	156
Contrasti	362
Creek	524
Epoca	186
Escape	546
Galassia	550
Harmony	254
Life	536
Re_Solution	142
Realstone_Cardoso	92
Realstone_Jerusalem	98
Realstone_Lunar	64
Realstone_Navigli	70
Realstone_PietrAntica	74
Realstone_Quarzite	104
Realstone_Rain	86
Realstone_Slate	80
Replace	528
Rewind	162
Season	538
Stoneway_Ardesia	108
Stoneway_Barge Antica	114
Studio	180
Unitech	392
Woodcraft	272
Woodmania	214
Woodsense	198
Woodshape	242
Woodspirit	230
Woodstory	246

**Outdoor**

Bistrot	42
Boom	156
Contrasti	362
Creek	524
Epoca	186
Escape	546
Galassia	550
Harmony	254
Life	536
Re_Solution	142
Realstone_Cardoso	92
Realstone_Jerusalem	98
Realstone_Lunar	64
Realstone_Navigli	70
Realstone_PietrAntica	74
Realstone_Quarzite	104
Realstone_Rain	86
Realstone_Slate	80
Replace	528
Rewind	162, 502
Season	538
Stoneway_Ardesia	108
Stoneway_Barge Antica	114
Stoneway_Porfido	120
Studio	180
Woodcraft	272
Woodmania	214
Woodsense	198
Woodshape	242
Woodspirit	230
Woodstory	246

**XT20**

Concept XT20	356
Patina XT20	348
Realstone_Cardoso XT20	306
Realstone_Jerusalem XT20	310
Realstone_Lunar XT20	284
Realstone_Navigli XT20	288
Realstone_PietrAntica XT20	292
Realstone_Quarzite XT20	314
Realstone_Rain XT20	302
Realstone_Slate XT20	298
Rewind XT20	352
Stoneway_Ardesia XT20	318
Stoneway_Barge Antica XT20	322
Stoneway_Porfido XT20	324
Woodliving XT20	334
Woodmania XT20	344
Woodsense XT20	326
Woodspace XT20	330
Woodtale XT20	338

**Glossy**

Bistrot	42
Brick Glossy	378
Candy	554
Energy	578
Fantasy	518
Frame	490
Freestyle	498
Grace	560
Maiora	18
Imperiale	56
Off	480
Unitech	392



## UNO STILE ITALIANO TRA DESIGN E TRADIZIONE

*An Italian style forged from design and tradition  
Italienischer Stil, dem Design und der Tradition verpflichtet  
Un style italien entre design et tradition  
Un estilo italiano entre diseño y tradición  
Итальянский стиль в духе дизайна и традиций*

### **Una storia di eccellenza, protagonista del nostro tempo**

Dal 1949 il marchio Ragno è uno dei protagonisti storici dello sviluppo e del successo dell'industria italiana delle piastrelle in ceramica nel mondo. Creatività e design innovativo caratterizzano una ricerca costante mirata ad ottenere la massima qualità del prodotto, attraverso soluzioni dalla forte espressività che fanno di Ragno un testimone autorevole di uno stile italiano inconfondibile e senza tempo apprezzato in tutto il mondo.

### **A history of excellence, a leader of our age**

The Ragno brand has been one of the historic protagonists of the growth and success of the Italian ceramic tile industry all over the world since 1949. Creativity and innovative design are key to a process of constant renewal that drives to achieve the utmost product quality through strongly expressive solutions, that make Ragno a fine example of an unmistakable, timeless Italian style, popular and respected all over the world.

### **Eine Geschichte im Zeichen der Exzellenz, am Puls der Zeit**

Seit 1949 prägt die Marke Ragno die Entwicklung und den Erfolg der italienischen Keramikfliesenbranche in der ganzen Welt. Kreativität und innovatives Design sind die wesentlichen Faktoren des beständigen Strebens nach erstklassiger Produktqualität mit Hilfe von außergewöhnlichen Produkten, die Ragno weltweit zu einem Begriff für unverwechselbares, zeitloses Italian Design machen.

### **Une histoire d'excellence, un acteur des temps modernes**

Depuis 1949, la marque Ragno figure au premier rang des acteurs historiques qui ont fait l'essor de l'industrie italienne des carreaux de céramique et son succès dans le monde. Créativité et design novateur : les points forts d'une recherche incessante axée sur la qualité maximale du produit, avec la puissance d'expression des solutions qui font de Ragno le témoin prestigieux d'un style italien inimitable et intemporel, apprécié de par le monde.

### **Una historia de excelencia, protagonista de nuestro tiempo**

Desde 1949 la marca Ragno es una de las protagonistas históricas del desarrollo y el éxito de la industria italiana de azulejos de cerámica en el mundo. Una investigación constante, caracterizada por la creatividad y por la innovación en el diseño y orientada a conseguir la máxima calidad del producto, ofrece soluciones de vigorosa expresividad que convierten a Ragno en un prestigioso ejemplo de un estilo italiano inconfundible y atemporal, valorado en el mundo entero.

### **История великих достижений, Герой нашего времени**

С 1949 года бренд Ragno является одним из первых и основных участников развития и успеха итальянской керамической промышленности во всем мире. Творчество и инновационный дизайн - таковы характеристики непрерывных поисков, направленных на получение максимального качества продукции. Предлагаемые решения большой выразительной силы делают Ragno авторитетным представителем неподражаемого итальянского стиля, не боящегося времени и пользующегося успехом во всем мире.



**RAGNO**

## UN'ESTETICA SU MISURA PER IL PROGETTO CONTEMPORANEO

*Style tailored to contemporary architecture*  
*Eine maßgeschneiderte Ästhetik für moderne Gestaltungskonzepte*  
*Une esthétique sur mesure pour le projet contemporain*  
*Una estética a medida para el proyecto contemporáneo*  
*Эстетика на заказ для современных проектов*

### **Soluzioni versatili, design creativo**

La ricerca di Ragno propone soluzioni dall'estetica originale che rispondono alle nuove esigenze dell'abitare con proposte coordinate tra pavimenti e rivestimenti, formati modulari, decorazioni e pezzi speciali di finitura per un effetto "total look". Ragno interpreta la materia ceramica per trasformarla in complemento d'arredo, capace di dialogare con le tendenze della moda e dell'interior design.

### **Versatile solutions, creative design**

Ragno offers solutions with a highly original look that respond to the latest needs in home design with matching floor and wall tiles, modular tile sizes, decorative pieces and trims, all conceived for a "total look" effect. Ragno transforms fired clay into an item of furnishing, in tiles that dialogue perfectly with fashion and interior design trends.

### **Vielseitige Lösungen, kreatives Design**

Ragno bietet Lösungen mit einer einzigartigen Ästhetik, die den neuen Anforderungen an das zeitgemäße Wohnen mit abgestimmten Boden- und Wandbekleidungskonzepten, modularen Formaten, Dekoren und Zubehörteilen im „Total Look“ gerecht werden. Ragno interpretiert das keramische Material und verwandelt es in ein Gestaltungselement, das den aktuellen Trends der Mode und des Interior Designs Rechnung trägt.

### **Des solutions multifonctions, design créatif**

La recherche Ragno aboutit à des solutions originales qui répondent aux nouvelles exigences du secteur résidentiel, avec des propositions coordonnées pour les sols et les murs qui traduisent le concept de « total look » par la modularité des formats, par les décorations et par les pièces spéciales de finition. Ragno interprète la céramique pour la transformer en un véritable complément d'ameublement, à même de dialoguer avec les tendances de la mode et du design d'intérieur.

### **Soluciones versátiles, diseño creativo**

La investigación de Ragno brinda soluciones de estética original que responden a las nuevas exigencias de la vivienda con propuestas coordinadas entre pavimentos y revestimientos, formatos modulares, motivos decorativos y piezas especiales de acabado para conseguir un efecto de "imagen total". Ragno interpreta la materia cerámica para transformarla en complemento decorativo capaz de convivir en armonía con las tendencias de la moda y el interiorismo.

### **Универсальные решения, творческий дизайн**

Исследования Ragno предлагают решения с оригинальной эстетикой, отвечающие на новые требования оформления жилья: сочетающиеся полы и облицовка стен, модульные форматы, декоры и специальные отделочные элементы для создания эффекта "total look". В своем подходе к керамическому материалу Ragno превращает его в дополнение обстановки, вступающее в диалог с тенденциями моды и дизайна интерьеров.



**RAGNO**

## IL BAGNO, LA MIA STANZA PREFERITA

*The bathroom, my favourite room*  
*Das Bad: Mein Lieblingszimmer*  
*La salle de bains, ma pièce préférée*  
*El baño, mi estancia preferida*  
*Ванная, моя любимая комната*

### **Lo spazio dell'intimità, unicità di stile**

Ragno cambia il modo di pensare il bagno: uno spazio creativo dove poter combinare design e funzionalità, in cui sentirsi liberi di esprimere il proprio gusto e il proprio stile. Tonalità ricercate, superfici dall'aspetto morbido e naturale per rivestimenti e pavimenti, un'estetica sobria e raffinata che riveste le stanze del bagno trasformandole in luoghi dove poter ritrovare la propria intimità.

### **Intimate space, unique style**

Ragno takes a revolutionary new look at the bathroom, making it a creative space, where design and function can be combined, where we are all free to express our own taste and style. Sophisticated colour shades, surface finishes with a soft, natural look for floor and wall tiles, and a design approach of understated elegance that transforms bathrooms into places where we rediscover our intimate selves.

### **Das private Refugium, stilvolle Einheitlichkeit**

Ragno revolutioniert das Badkonzept: Ein kreativer Raum, in dem Design und Funktionalität harmonisch miteinander verschmelzen und die individuellen Lebens- und Stilwelten ihren höchsten Ausdruck finden. Wand- und Bodenbeläge in erlesenen Farben, Oberflächen mit weicher und natürlicher Ausstrahlung und schlichte Eleganz schaffen Raum für individuelle Badkultur.

### **L'espace de l'intimité, singularité de style**

Ragno révolutionne le concept de la salle de bains : un espace de créativité, où coexistent design et fonctionnalité, où les goûts et les styles peuvent s'exprimer en toute liberté. Des tonalités sophistiquées, des surfaces douces et naturelles pour les murs et les sols, une esthétique sobre et raffinée qui envahit la salle de bains et la transforme en un espace où retrouver son intimité.

### **El espacio de la intimidad, unicidad de estilo**

Ragno cambia la manera de concebir el baño: un espacio creativo en el que poder combinar diseño y funcionalidad, en el que gozar de total libertad para expresar un gusto y un estilo personales. Tonalidades sofisticadas, superficies de aspecto suave y natural tanto para el revestimiento como para la pavimentación, una estética sobria y refinada que reviste los cuartos de baño transformándolos en lugares en los que poder reencontrarse con la intimidad.

### **Уютное пространство, уникальный стиль**

Ragno радикально изменяет понятие ванной комнаты: она становится творческим интерьером, объединяющим в себе дизайн и функциональность, в котором можно свободно выражать собственный вкус и стиль. Изысканные тона, настенные и напольные поверхности с мягким и натуральным видом, сдержанная и утонченная эстетика оформляют ваннe комнаты, превращая их в места, где можно обрести уют и покой.



**RAGNO**





**RAGNO** 

## IL RISPETTO PER L'AMBIENTE: UN PENSIERO SOSTENIBILE

*Environment-friendliness: sustainable thinking*  
*Umweltschutz: Ein nachhaltiger Gedanke*  
*Le respect de la nature : une pensée durable*  
*Respetar el medio ambiente: una idea sostenible*  
*Уважение к окружающей среде: экологически рациональное мышление*

### **Qualità certificata**

Una passione antica e un grande rispetto per la "terra": amare la ceramica significa anche rispettare la natura. Un uso razionale e attento delle risorse naturali e delle energie permette di ridurre al massimo l'impatto ambientale, grazie al recupero di materiali ed acque di scarto nel ciclo produttivo e con l'investimento in impianti tecnologicamente all'avanguardia che ottimizzano i processi produttivi. Un percorso che ha portato Ragno ad ottenere diverse certificazioni ambientali tra cui il marchio europeo di qualità ecologica di prodotto Ecolabel® e a diventare socio del Green Building Council Italia, associazione che promuove la cultura dell'edilizia sostenibile ed energeticamente efficiente attraverso lo standard di certificazione Leed®.

### **Certified quality**

A love with its roots in antiquity, and great respect for the earth and the clays it yields; loving ceramics also means loving nature. The rational, intelligent use of natural resources and energy enables us to minimise environmental impact, by recycling waste materials and water in the production cycle, and investing in plants at the technological state of the art, which optimise production processes. A policy that has won Ragno several forms of environmental certification, including the European Ecolabel® product environmental quality mark and the membership of the Green Building Council Italy, an association that promotes sustainable, energy-efficient building through the Leed® certification standard.

### **Zertifizierte Qualität**

Ein jahrzehntelanges Engagement und ein großer Respekt für die „Natur“: Denn die Keramik lieben bedeutet, die Natur respektieren. Ein rationeller, umsichtiger Umgang mit den natürlichen Ressourcen und Energien reduziert die Umweltbelastung auf ein Mindestmaß. Abprodukte und Abwässer aus dem Herstellungsprozess werden recycelt. Ragno investiert überdies in hochmoderne Anlagen, um den Produktionsprozess zu optimieren. Ragno besitzt mehrere Umweltzertifizierungen, darunter das europäische Umweltgütesiegel Ecolabel®, und ist Mitglied der Gesellschaft Green Building Council Italia, die sich anhand des Leed® Zertifizierungsprogramms für nachhaltiges und energieeffizientes Bauen einsetzt.

### **Qualité certifiée**

Une passion ancestrale et un grand respect de la « terre », parce qu'aimer la céramique, c'est aussi respecter la nature. L'utilisation rationnelle et attentive des ressources et des énergies naturelles permet de réduire au minimum les impacts sur l'environnement. En effet, les déchets et les eaux de production sont récupérés, et des investissements ont été faits dans les technologies de pointe pour optimiser les procédés de fabrication. Un parcours qui a valu à Ragno plusieurs certifications environnementales, dont le label écologique euro-

péen Ecolabel®, et qui en a fait un membre du Green Building Council Italia, association qui prône la culture du bâtiment durable, à haut rendement énergétique par le référentiel LEED®.

### **Calidad certificada**

Una vieja pasión y un enorme respeto por la "tierra": amar la cerámica también significa respetar la naturaleza. Un uso racional y consciente de los recursos naturales y de la energía permite reducir al mínimo el impacto medioambiental gracias a la recuperación de materiales y aguas residuales en el ciclo de fabricación y con la inversión en instalaciones de vanguardia que optimizan los procesos productivos. Un camino que ha llevado a Ragno a conseguir varias certificaciones medioambientales, entre las que cabe destacar el sello europeo Ecolabel® de calidad ecológica del producto, y a convertirse en miembro del Green Building Council Italia, asociación que promueve una cultura de la construcción sostenible y energéticamente eficiente a través del estándar de certificación Leed®.

### **Сертифицированное качество**

Давнее увлечение и большое уважение к "земле" - любовь к керамике выражается также в уважении к природе. Рациональное и внимательное потребление натуральных ресурсов и энергии позволяет максимально снизить отрицательное воздействие на окружающую среду. Тому заслуга - повторное использование отработанных материалов и воды в производственном цикле, вложение средств в технологически передовое оборудование, оптимизирующее производственные процессы.

Этот подход побудил Ragno к получению различных экологических сертификатов, в том числе европейской маркировки экологичного качества продукции Ecolabel®, а также к вступлению в члены ассоциации Green Building Council Italia, продвигающей культуру экорационального и энергетически эффективного строительства путем внедрения сертифицирующего стандарта Leed®.



**MAIORA**  
**MARBLE & CONCRETE EFFECT**

- Lastre in Gres Porcellanato*
- Porcelain Stoneware Slabs*
- Feinsteinzeugplatten*
- Dalles en Grès Cérame*
- Placas de Gres Porcelánico*
- Плиты из керамогранита*

# Maiora

120x278 120x240 120x120



R7EE Maiora\_Marble Effect Paonazetto rettificato 120x278  
Maiora Custom Mosaic 30x32,5

# Maiora\_Marble Effect Paonazzetto

120x278



R7EQ Maiora\_Marble Effect Paonazzetto Glossy rettificato 120x278  
R7EE Maiora\_Marble Effect Paonazzetto rettificato 120x278

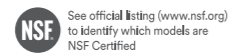

- G** Naturale/Matt
- F** Glossy

gres fine porcellanato colorato in massa - rettificato monocalibro / colorbody fine porcelain stoneware - rectified monocaliber / durchgefärbtes feinsteinzeug - rektifiziert, in einem werkmaß / grès cérame fin coloré dans la masse - rectifié monocalibre / gres porcelánico fino coloreado en toda la masa - rectificado monocalibre / гомогенный мелкозернистый керамогранит - ректифицированный монокалиберный

superfici / surfaces / finitions / oberflächen / superficies / поверхности:  
naturale/matt + glossy

## Marble Effect variations\*



Maiora\_Marble Effect Paonazzetto 120x278

# Maiora\_Marble Effect Arabescato

120x178 120x240 120x120



R7EL Maiora\_Marble Effect Arabescato Glossy rettificato 120x278

**F** Glossy

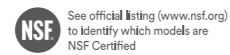

R6RM Maiora\_Marble Effect Arabescato Glossy rettificato 120x240

**F** Glossy



R6RX Maiora\_Marble Effect Arabescato Glossy rettificato 120x120

**F** Glossy

## Marble Effect variations\*



Maiora\_Marble Effect Arabescato 120x278



Maiora\_Marble Effect Arabescato 120x240

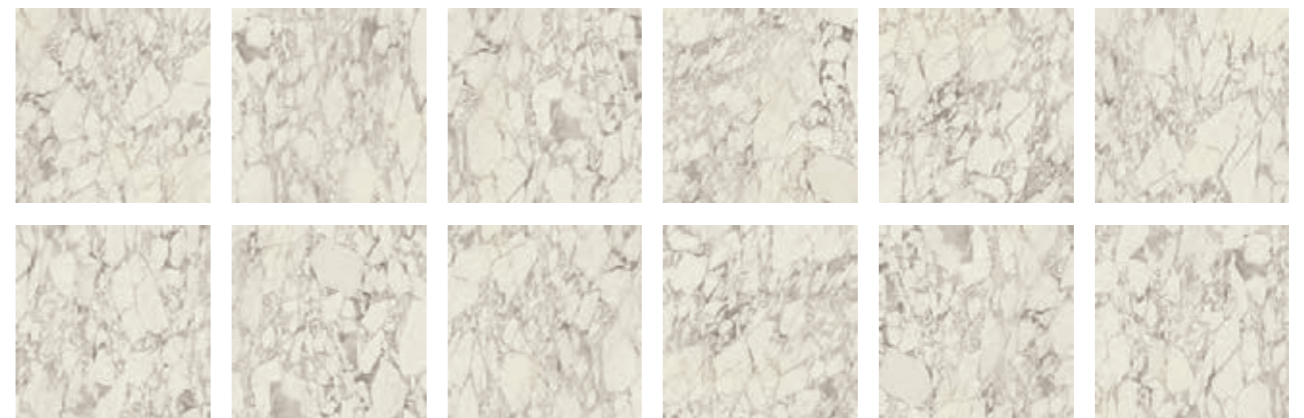

Maiora\_Marble Effect Arabescato 120x120

# Maiora\_Marble Effect Statuario

120x278 120x240 120x120



**R7EH** Maiora\_Marble Effect Statuario rettificato 120x278  
**R7EM** Maiora\_Marble Effect Statuario Glossy rettificato 120x278

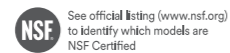

**G** Naturale/Matt  
**F** Glossy

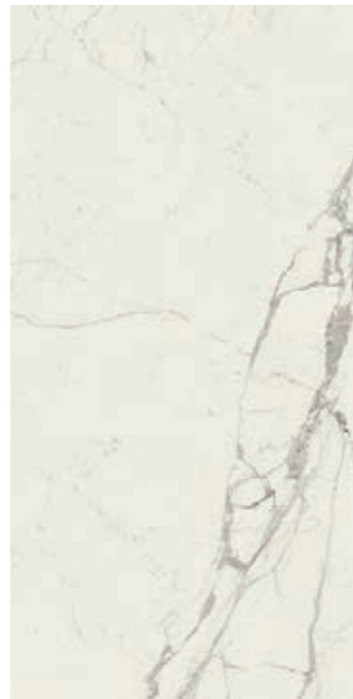

**R6RT** Maiora\_Marble Effect Statuario rettificato 120x240  
**R6RN** Maiora\_Marble Effect Statuario Glossy rettificato 120x240

**G** Naturale/Matt  
**F** Glossy

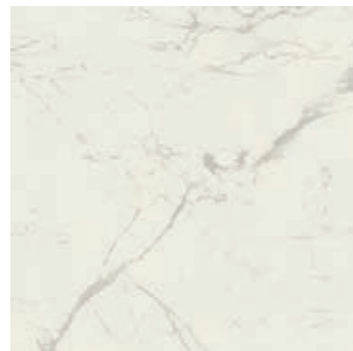

**R6SE** Maiora\_Marble Effect Statuario rettificato 120x120  
**R6RY** Maiora\_Marble Effect Statuario Glossy rettificato 120x120

**G** Naturale/Matt  
**F** Glossy

## Marble Effect variations\*



Maiora\_Marble Effect Statuario 120x278

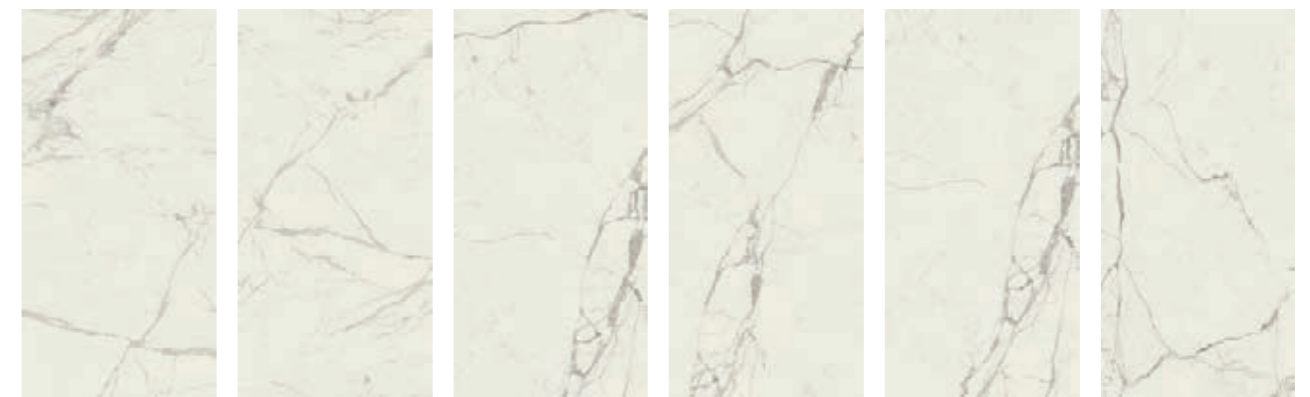

Maiora\_Marble Effect Statuario 120x240

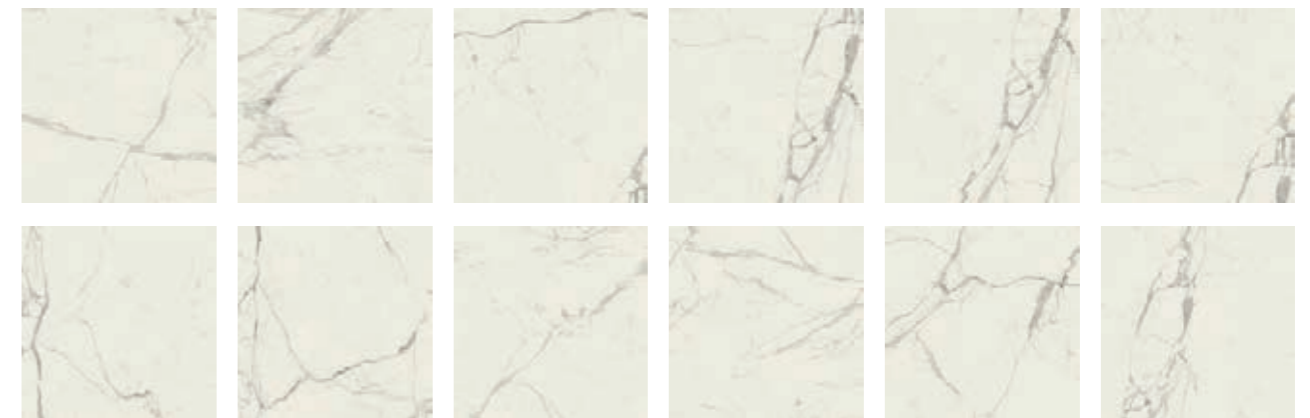

Maiora\_Marble Effect Statuario 120x120

# Maiora\_Marble Effect Calacatta Oro

120x278 120x240 120x120



**R7ED** Maiora\_Marble Effect Calacatta Oro rettificato 120x278  
**R7EK** Maiora\_Marble Effect Calacatta Oro Glossy rettificato 120x278

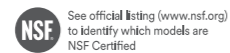

**G** Naturale/Matt  
**F** Glossy

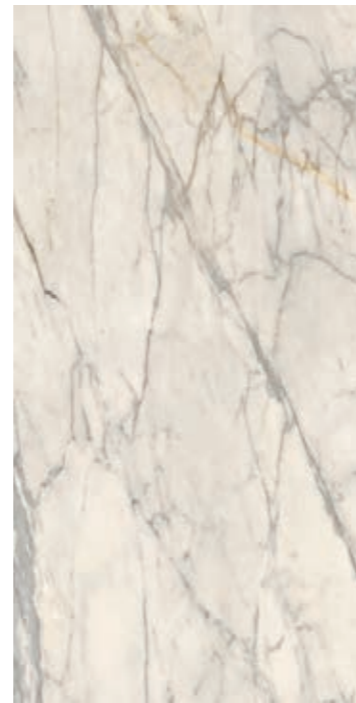

**R6RS** Maiora\_Marble Effect Calacatta Oro rettificato 120x240  
**R6RL** Maiora\_Marble Effect Calacatta Oro Glossy rettificato 120x240

**G** Naturale/Matt  
**F** Glossy

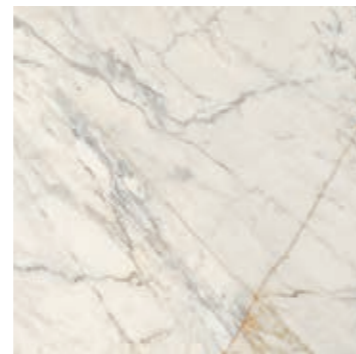

**R6SD** Maiora\_Marble Effect Calacatta Oro rettificato 120x120  
**R6RW** Maiora\_Marble Effect Calacatta Oro Glossy rettificato 120x120

**G** Naturale/Matt  
**F** Glossy

## Marble Effect variations\*



Maiora\_Marble Effect Calacatta Oro 120x278



Maiora\_Marble Effect Calacatta Oro 120x240



Maiora\_Marble Effect Calacatta Oro 120x120

# Maiora\_Marble Effect Emperador

120x278 120x240 120x120

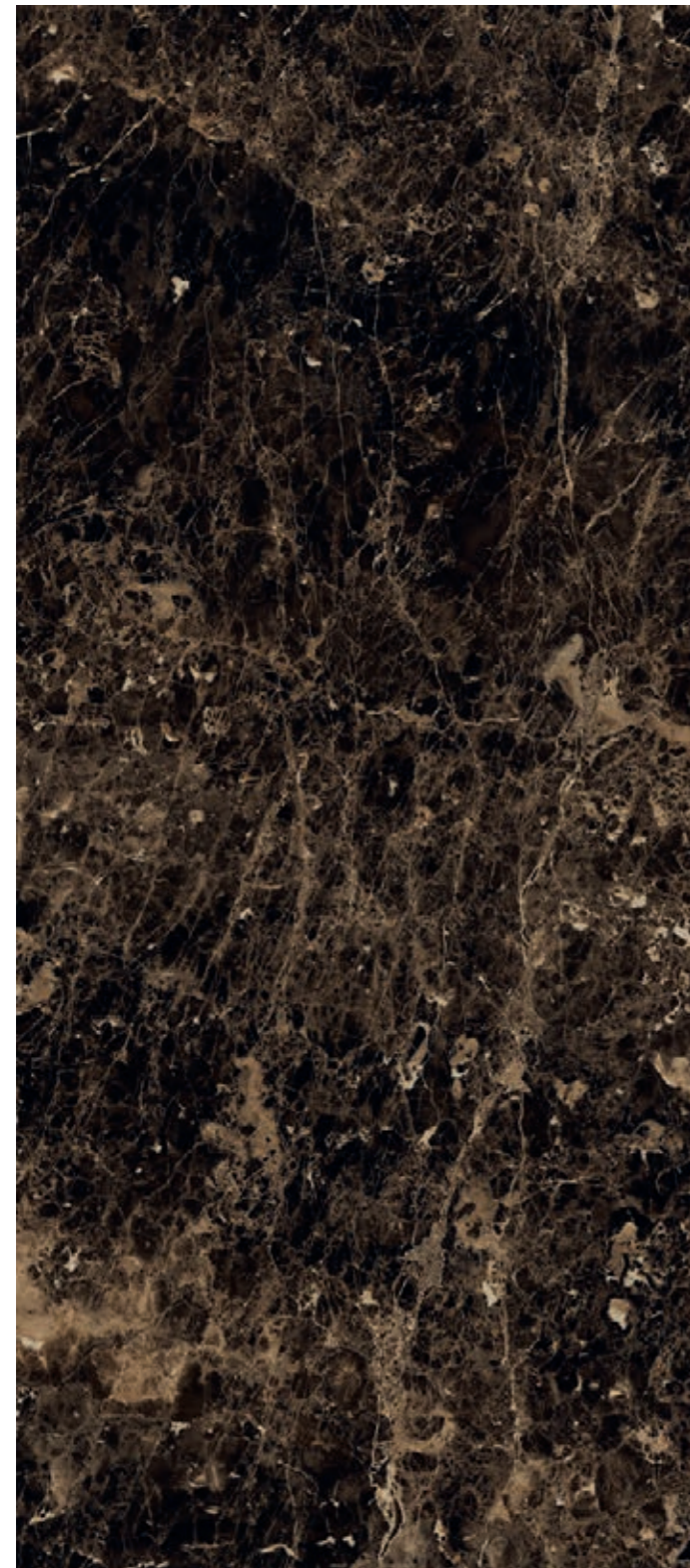

R7EN Maiora\_Marble Effect Emperador Glossy rettificato 120x278

**F** Glossy

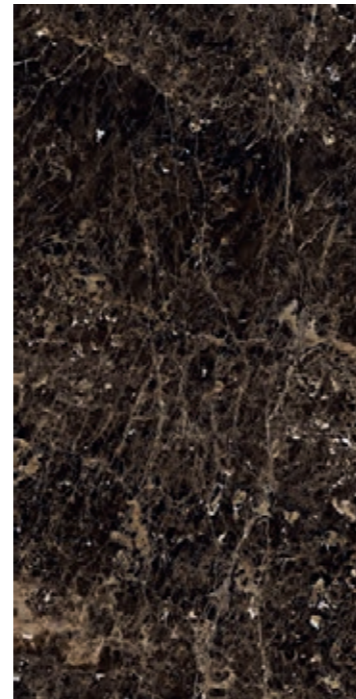
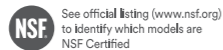

R6RP Maiora\_Marble Effect Emperador Glossy rettificato 120x240

**F** Glossy

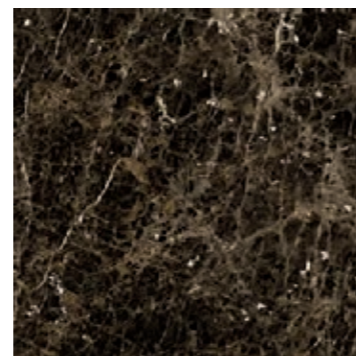

R6RZ Maiora\_Marble Effect Emperador Glossy rettificato 120x120

**F** Glossy

## Marble Effect variations\*

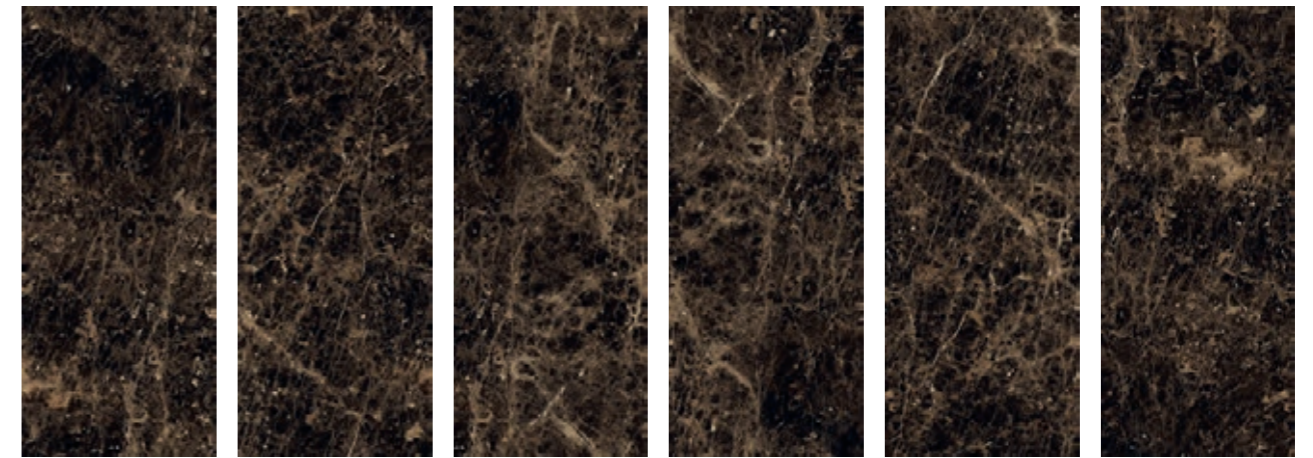

Maiora\_Marble Effect Emperador 120x278

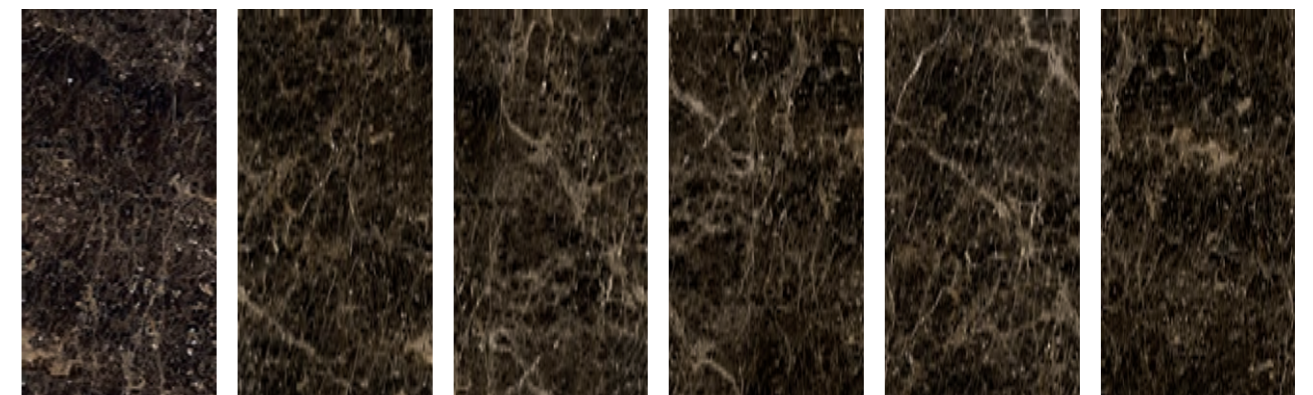

Maiora\_Marble Effect Emperador 120x240



Maiora\_Marble Effect Emperador 120x120



# Maiora\_Marble Effect Grafite

120x278 120x240 120x120



**R7EP** Maiora\_Marble Effect Grafite rettificato 120x278  
**R7GH** Maiora\_Marble Effect Grafite Glossy rettificato 120x278

- G** Naturale/Matt
- F** Glossy

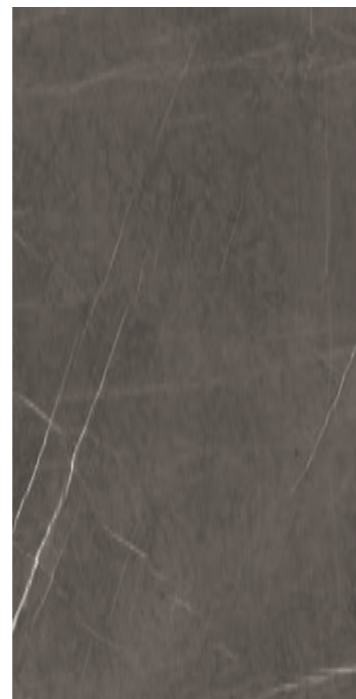
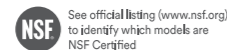

**R6RU** Maiora\_Marble Effect Grafite rettificato 120x240  
**R6RQ** Maiora\_Marble Effect Grafite Glossy rettificato 120x240

- G** Naturale/Matt
- F** Glossy



**R6SF** Maiora\_Marble Effect Grafite rettificato 120x120  
**R6SO** Maiora\_Marble Effect Grafite Glossy rettificato 120x120

- G** Naturale/Matt
- F** Glossy

## tech info

★

Marble Effect Variations (vedi Appendice pag. 598 / see Appendix page 598 / siehe Anhang S. 598 / voir Annexe page 598 / véase la pág. 598 del Apéndice / смотри приложение на стр. 598)

## Marble Effect variations\*

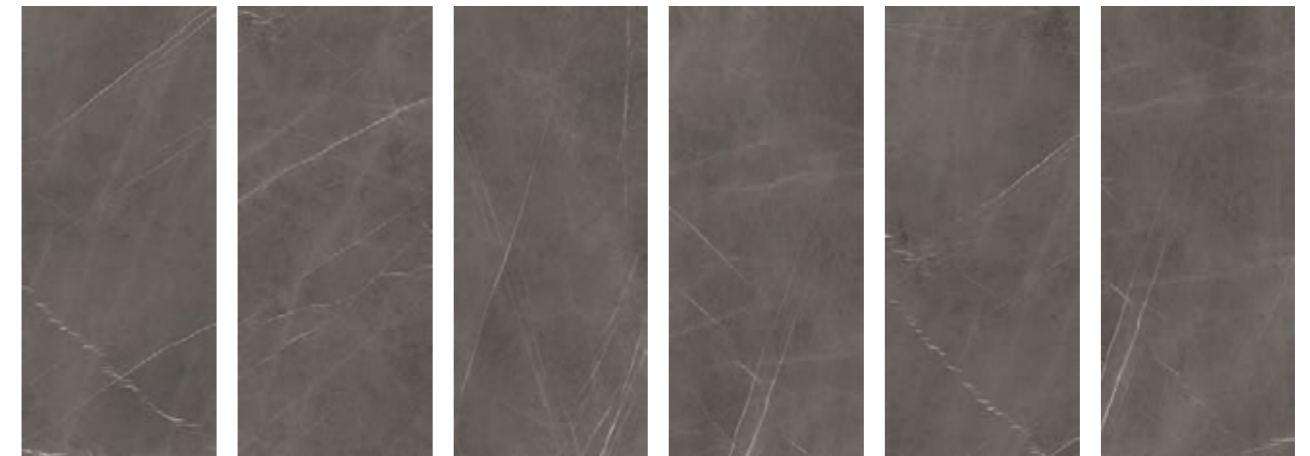

Maiora\_Marble Effect Grafite 120x278

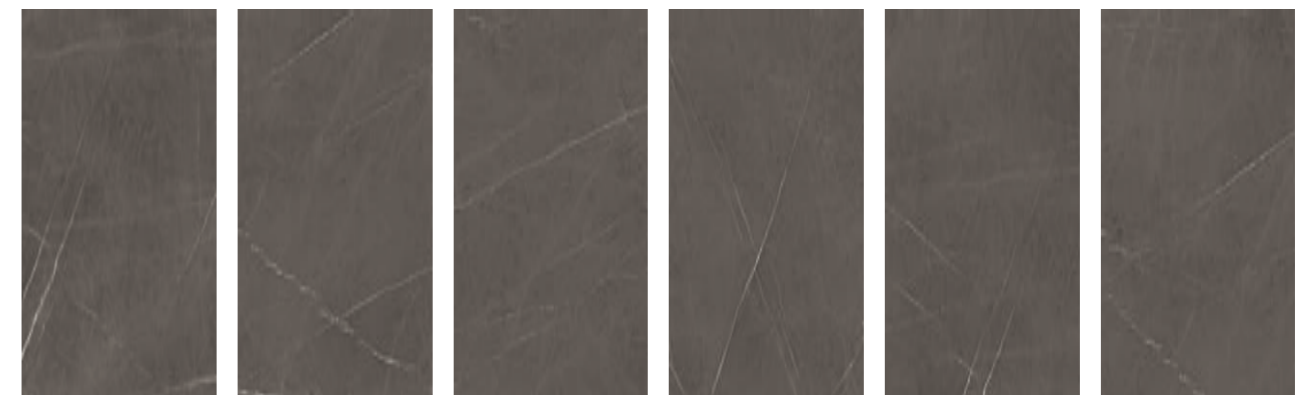

Maiora\_Marble Effect Grafite 120x240

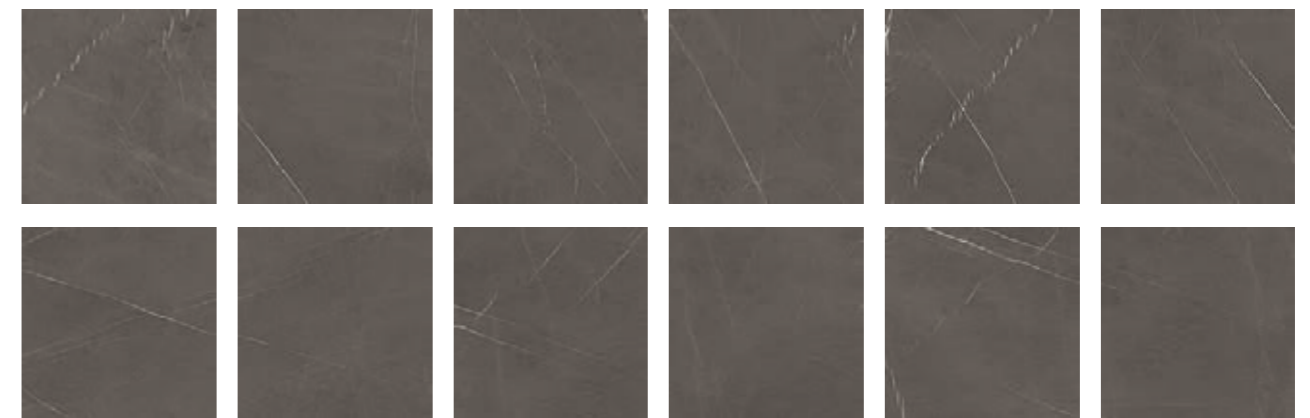

Maiora\_Marble Effect Grafite 120x120



Significativa variazione di aspetto superficiale, grafica e colore da piastrella a piastrella e all'interno della stessa piastrella. Si consiglia di visionare la gamma cromatica prima della selezione del materiale. / Significant variation in texture, pattern and colour from tile to tile within the same production run. The colour range should be viewed before selecting the material. / Bedeutende Variation in Aussehen, Struktur und Farbe von Fliese zu Fliese und in ein und derselben Fliese. Es wird empfohlen, das Farbsortiment vor der Auswahl des Materials zu prüfen. / Variation significative au niveau de l'aspect, de la fantaisie et de la couleur entre les carreaux et au sein d'un même carreau. Il est recommandé de consulter la gamme des couleurs avant de sélectionner le matériel. / Variación considerable en el aspecto superficial, los motivos y el color entre un azulejo y otro y dentro del propio azulejo. Es aconsejable visualizar la gama cromática antes de seleccionar el material. / Значительные отличия вида поверхности, графики и цвета у разных плиток и на одной и той же плитке. Перед отбором материала рекомендуется просмотреть цветовую гамму.

imballi (vedi Appendice pag. 562) / packaging (see Appendix page 562) / verpackungen (siehe Anhang S. 562) / emballages (voir Annexe page 562) / embalajes (véase la pág. 562 del Apéndice) / упаковки (смотри приложение на стр. 562)

	Scatole / Box / Karton / Boite / Caja / Коробки		Pallet / Pallet / Palette / Palette / Pallet / Поддон		
	M <sup>2</sup>	KG	M <sup>2</sup>	KG	≠ mm

fondi / plain tiles / grundfliesen / fonds / fondos / фоновая плитка							
120x278	1	3,34	52,99	18	60,05	1.074,00	6,0
120x240	1	2,88	45,90	20	57,60	1.021,00	6,0
120x120	1	1,44	22,95	24	34,56	615,00	6,0

# Maiora\_Concrete Effect Bianco

120x278 120x240 120x120



(slider 96)



R7GL Maiora\_Concrete Effect Bianco rettificato 120x278

**H** Naturale/Matt

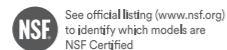

## Concrete Effect variations\*



Maiora\_Concrete Effect Bianco 120x278



Maiora\_Concrete Effect Bianco 120x240



Maiora\_Concrete Effect Bianco 120x120

# Maiora\_Concrete Effect Grigio Chiaro

120x278 120x240 120x120



**R7GM** Maiora\_Concrete Effect Grigio Chiaro rettificato 120x278

**H** Naturale/Matt

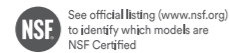

**R6S1** Maiora\_Concrete Effect Grigio Chiaro rettificato 120x240

**H** Naturale/Matt

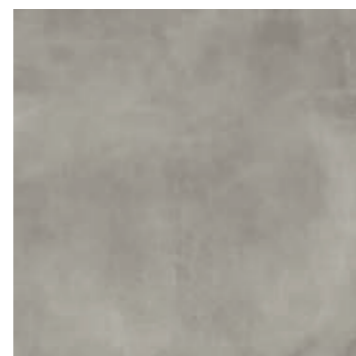

**R6SN** Maiora\_Concrete Effect Grigio Chiaro rettificato 120x120

**H** Naturale/Matt

## Concrete Effect variations\*



Maiora\_Concrete Effect Grigio Chiaro 120x278



Maiora\_Concrete Effect Grigio Chiaro 120x240



Maiora\_Concrete Effect Grigio Chiaro 120x120

# Maiora\_Concrete Effect Grigio Scuro

120x278 120x240 120x120



**R7GN** Maiora\_Concrete Effect Grigio Scuro rettificato 120x278

**H** Naturale/Matt

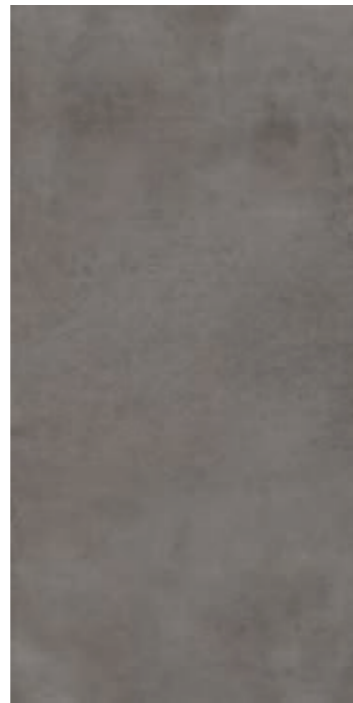
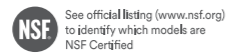

**R6SK** Maiora\_Concrete Effect Grigio Scuro rettificato 120x240

**H** Naturale/Matt



**R6SP** Maiora\_Concrete Effect Grigio Scuro rettificato 120x120

**H** Naturale/Matt

## Concrete Effect variations\*



Maiora\_Concrete Effect Grigio Scuro 120x278



Maiora\_Concrete Effect Grigio Scuro 120x240



Maiora\_Concrete Effect Grigio Scuro 120x120

# Maiora\_Concrete Effect Botanical

120x278 120x240

gres fine porcellanato colorato in massa - rettificato monocalibro / colorbody fine porcelain stoneware - rectified monocaliber / durchgefärbtes feinsteinzeug - rektifiziert, in einem werkmaß / grès cérame fin coloré dans la masse - rectifié monocalibre / gres porcelánico fino coloreado en toda la masa - rectificado monocalibre / гомогенный мелкозернистый керамогранит - ректифицированный монокалиберный

superfici / surfaces / finitions / oberflächen / superficies / поверхности: naturale/matt

## Custom Decors



**R817** Maiora\_Concrete Effect Decoro Botanical A rettificato \* 120x278  
**R77X** Maiora\_Concrete Effect Decoro Botanical A rettificato \* 120x240



**R81C** Maiora\_Concrete Effect Decoro Botanical B rettificato \* 120x278  
**R77Y** Maiora\_Concrete Effect Decoro Botanical B rettificato \* 120x240



**R81D** Maiora\_Concrete Effect Decoro Botanical C rettificato \* 120x278  
**R77Z** Maiora\_Concrete Effect Decoro Botanical C rettificato \* 120x240

### tech info

Concrete Effect variations (vedi Appendice pag. 598 / see Appendix page 598 / siehe Anhang S. 598 / voir Annexe page 598 / véase la pág. 598 del Apéndice / смотри приложение на стр. 598)

★

La produzione del Decoro Botanical è su richiesta / Decoro Botanical is produced to order / Die Herstellung von Decoro Botanical erfolgt auf Anfrage / La production de Decoro Botanical se fait à la demande / La producción del Decoro Botanical se realiza bajo pedido / Производство Decoro Botanical осуществляется по заказу.



Apprezzabili differenze nell'aspetto di superficie e grafica all'interno della stessa produzione. / Clearly distinguishable differences in texture and pattern within the same production run. / Auffällige Unterschiede in Aussehen und Struktur innerhalb der gleichen Produktionscharge. / Différences visibles au niveau de l'aspect et de la fantaisie entre les carreaux du même lot de production. / Diferencias visibles en el aspecto de la superficie y los motivos dentro de un mismo lote de producción. / Заметьные отличия вида поверхности и графики в одной и той же партии.

imballi (vedi Appendice pag. 585) / packaging (see Appendix page 585) / verpackungen (siehe Anhang S. 585) / emballages (voir Annexe page 585) / embalajes (véase la pág. 585 del Apéndice) / упаковки (смотри приложение на стр. 585)

Scatole / Box / Karton / Pallet / Pallet / Palette /  
 Boite / Caja / Коробки Palette / Pallet / Поддон

□ M<sup>2</sup> KG □ M<sup>2</sup> KG ≠ mm

fondi / plain tiles / grundfliesen / fonds / фоновая плитка						
120x278	1	3,34	52,99	18	60,05	1.074,00 6,0
120x240	1	2,88	45,90	20	57,60	1.021,00 6,0
120x120	1	1,44	22,95	24	34,56	615,00 6,0



## MARBLE EFFECT

- Gres Effetto Marmo*
- Marble Effect Porcelain Stoneware*
- Feinsteinzeug in Marmor-Optik*
- Grès Cérame Effet Marbre*
- Gres Porcelánico Efecto Marmol*
- Керамогранит с Эффектом Мрамора*

# Bistrot

75x150 75x75 60x60 30x60 21x18,2 7x28



R782 Bistrot Paonazetto rettificato 75x150

marble effect

# Bistrot

75x150 75x75 60x60 30x60 21x18,2 7x28

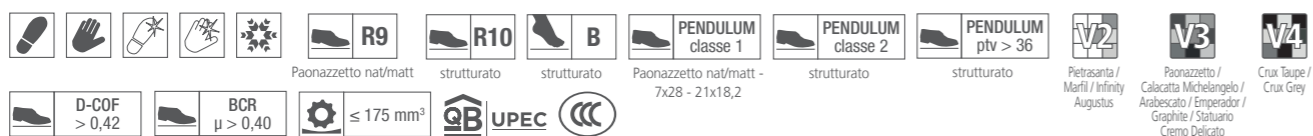

**D-COF**  
> 0,42  
Paonazzetto nat/mat -  
7x28 - 21x18,2 -  
strutturato

**BCR**  
 $\mu > 0,40$   
Paonazzetto nat/mat -  
strutturato

**R9**  
Paonazzetto nat/matt  
strutturato

**R10**  
strutturato

**B**  
strutturato

**PENDULUM**  
classe 1  
Paonazzetto nat/mat -  
7x28 - 21x18,2

**PENDULUM**  
classe 2  
strutturato

**PENDULUM**  
ptv > 36  
strutturato

**V2**  
Pietrasanta /  
Marfil / Infinity  
Augustus

**V3**  
Paonazzetto /  
Calacatta Michelangelo /  
Arabescato / Emperador /  
Graphite / Statuario  
Crema Delicata

**V4**  
Crux laupe /  
Crux Grey

**UPEC**

**gres fine porcellanato colorato in massa - rettificato monocalibro** / colorbody fine porcelain stoneware - rectified monocaliber / durchgefärbtes feinsteinzeug - rektifiziert, in einem werkmaß / grès cérame fin coloré dans la masse - rectifié monocalibre / gres porcelánico fino coloreado en toda la masa - rectificado monocalibre / гомогенный мелкозернистый керамогранит - ректифицированный монокалиберный

21x18,2 - 7x28

**gres porcellanato** / porcelain stoneware / feinsteinzeug / grès cérame émaillé / gres porcelánico / керамогранит

**superfici** / surfaces / finitions / oberflächen / superficies / поверхности:  
**naturale/matt + glossy + outdoor**

## Paonazzetto

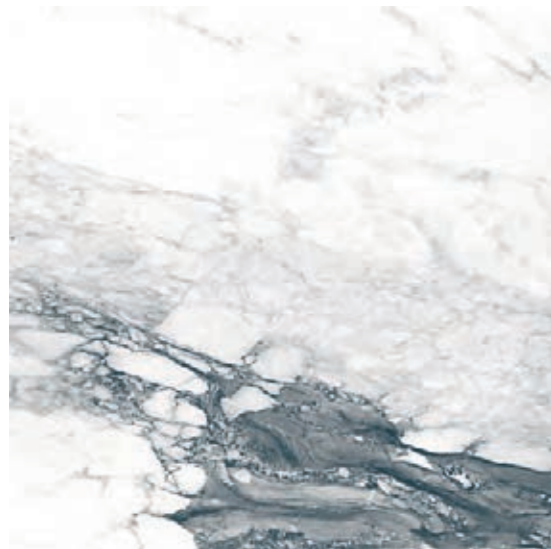

**G** Naturale/Matt  
**F** Glossy

## Pietrasanta

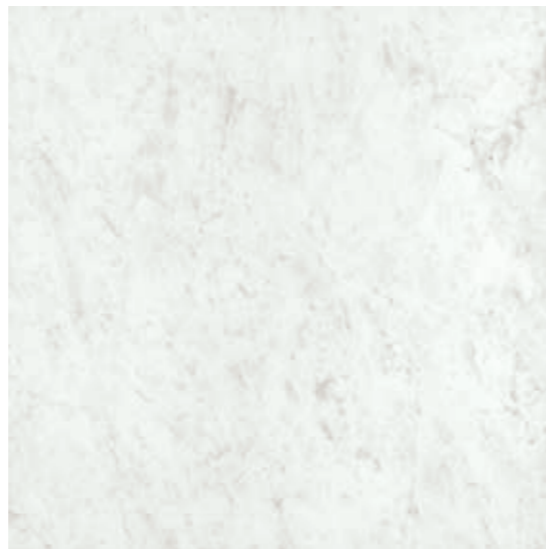

**G** Soft  
**F** Glossy

## Statuario

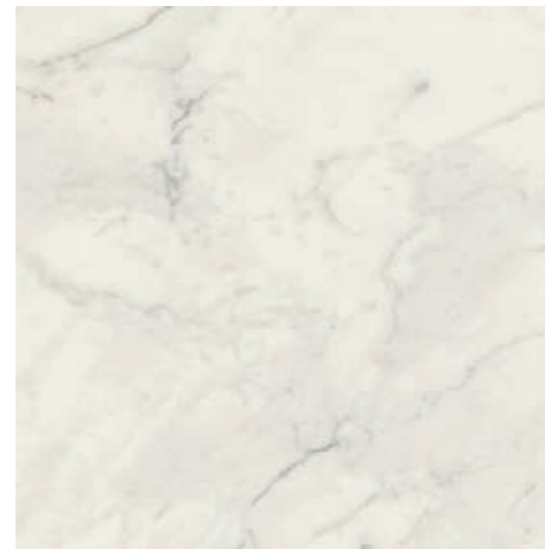

**H** Soft  
**F** Glossy

## Arabescato

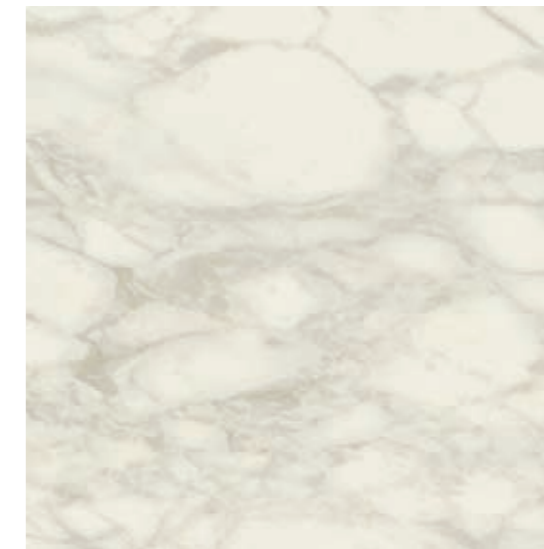

**H** Soft  
**F** Glossy



**R782** Bistrot Paonazzetto rettificato  
**R786** Bistrot Paonazzetto Glossy rettificato



**R50A** Bistrot Pietrasanta Soft rettificato  
**R50H** Bistrot Pietrasanta Glossy rettificato



**R5WD** Bistrot Statuario Soft rettificato  
**R5WM** Bistrot Statuario Glossy rettificato



**R5WC** Bistrot Arabescato Soft rettificato  
**R5WL** Bistrot Arabescato Glossy rettificato

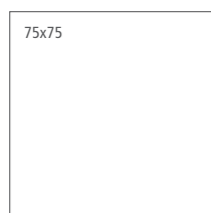

**R784** Bistrot Paonazzetto rettificato  
**R788** Bistrot Paonazzetto Glossy rettificato

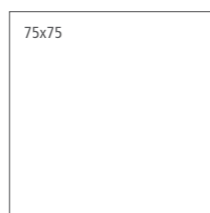

**R4LF** Bistrot Pietrasanta Soft rettificato  
**R4LG** Bistrot Pietrasanta Glossy rettificato

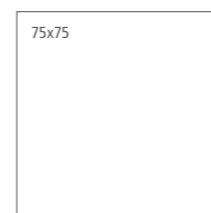

**R5WH** Bistrot Statuario Soft rettificato  
**R5WR** Bistrot Statuario Glossy rettificato

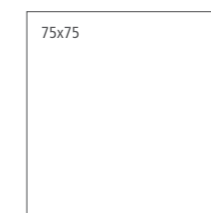

**R5WG** Bistrot Arabescato Soft rettificato  
**R5WQ** Bistrot Arabescato Glossy rettificato

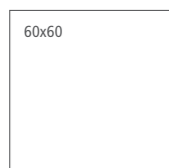

**R7DC** Bistrot Paonazzetto rettificato  
**R7DE** Bistrot Paonazzetto Glossy rettificato



**R7DG** Bistrot Paonazzetto rettificato

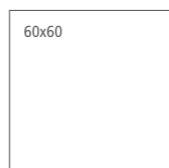

**R4MH** Bistrot Pietrasanta Soft rettificato  
**R4MJ** Bistrot Pietrasanta Glossy rettificato



**R4SL** Bistrot Pietrasanta Soft rettificato



**R5X4** Bistrot Statuario Soft rettificato  
**R5WY** Bistrot Statuario Glossy rettificato



**R5XA** Bistrot Statuario Soft rettificato

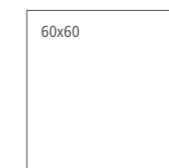

**R5X3** Bistrot Arabescato Soft rettificato  
**R5WX** Bistrot Arabescato Glossy rettificato

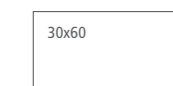

**R5X8** Bistrot Arabescato Soft rettificato



# Bistrot

75x150 75x75 60x60 30x60 21x18,2 7x28

gres fine porcellanato colorato in massa - rettificato monocalibro / colorbody fine porcelain stoneware - rectified monocaliber / durchgefärbtes feinsteinzeug - rektifiziert, in einem werkmaß / grès cérame fin coloré dans la masse - rectifié monocalibre / gres porcelánico fino coloreado en toda la masa - rectificado monocalibre / гомогенный мелкозернистый керамогранит - ректифицированный монокалиберный

21x18,2 - 7x28

gres porcellanato / porcelain stoneware / feinsteinzeug / grès cérame émaillé / gres porcelánico / керамогранит

superfici / surfaces / finitions / oberflächen / superficies / поверхности:  
naturale/matt + glossy + outdoor

marble effect

## Calacatta Michelangelo



**G** Soft

**F** Glossy



**R50C** Bistrot Calacatta Michelangelo Soft rettificato  
**R50J** Bistrot Calacatta Michelangelo Glossy rettificato

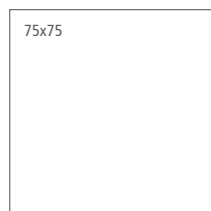

**R4RM** Bistrot Calacatta Michelangelo Soft rettificato  
**R4RJ** Bistrot Calacatta Michelangelo Glossy rettificato

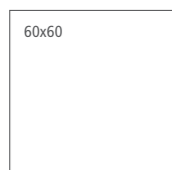

**R4MK** Bistrot Calacatta Michelangelo Soft rettificato  
**R4ML** Bistrot Calacatta Michelangelo Glossy rettificato



**R4RY** Bistrot Calacatta Michelangelo Soft rettificato

## Crema Delicato

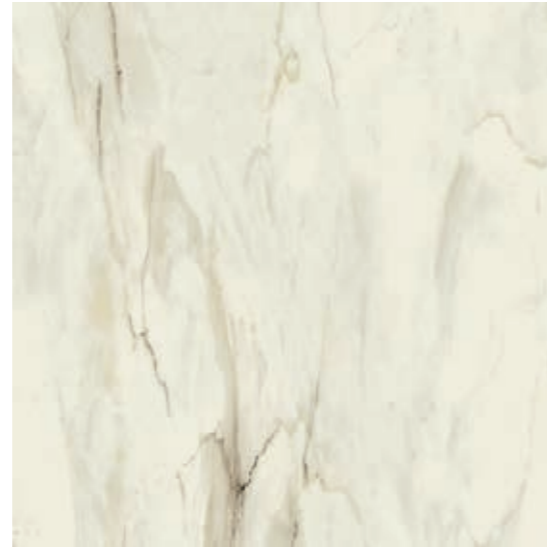

**H** Soft

**F** Glossy



**RG9Z** Bistrot Crema Delicato Soft rettificato  
**RG9X** Bistrot Crema Delicato Glossy rettificato

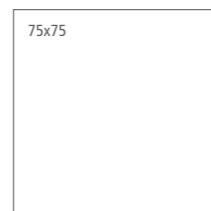

**RG1** Bistrot Crema Delicato Soft rettificato  
**RG3** Bistrot Crema Delicato Glossy rettificato

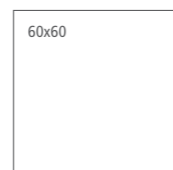

**RG9S** Bistrot Crema Delicato Soft rettificato  
**RG9P** Bistrot Crema Delicato Glossy rettificato

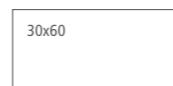

**RG5** Bistrot Crema Delicato Soft rettificato

## Marfil



**G** Soft

**F** Glossy

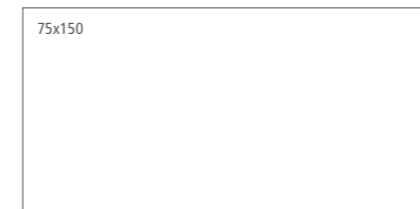

**R50D** Bistrot Marfil Soft rettificato  
**R50K** Bistrot Marfil Glossy rettificato

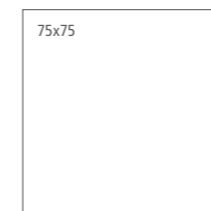

**R4RN** Bistrot Marfil Soft rettificato  
**R4RK** Bistrot Marfil Glossy rettificato



**R4MN** Bistrot Marfil Soft rettificato  
**R4MM** Bistrot Marfil Glossy rettificato

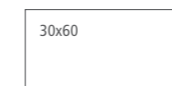

**R4SM** Bistrot Marfil Soft rettificato

## Crux Taupe



**H** Soft

**F** Glossy



**R50E** Bistrot Crux Taupe Soft rettificato  
**R50L** Bistrot Crux Taupe Glossy rettificato

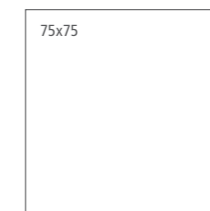

**R4UR** Bistrot Crux Taupe Soft rettificato  
**R4LQ** Bistrot Crux Taupe Glossy rettificato

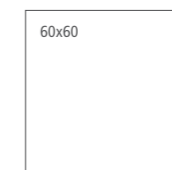

**R4UT** Bistrot Crux Taupe Soft rettificato  
**R4RR** Bistrot Crux Taupe Glossy rettificato

# Bistrot

75x150 75x75 60x60 30x60 21x18,2 7x28

gres fine porcellanato colorato in massa - rettificato monocalibro / colorbody fine porcelain stoneware - rectified monocaliber / durchgefärbtes feinsteinzeug - rektifiziert, in einem werkmaß / grès cérame fin coloré dans la masse - rectifié monocalibre / gres porcelánico fino coloreado en toda la masa - rectificado monocalibre / гомогенный мелкозернистый керамогранит - ректифицированный монокалиберный

21x18,2 - 7x28

gres porcellanato / porcelain stoneware / feinsteinzeug / grès cérame émaillé / gres porcelánico / керамогранит

superfici / surfaces / finitions / oberflächen / superficies / поверхности:  
naturale/matt + glossy + outdoor

marble effect

## Crux Grey



- H** Soft
- F** Glossy
- H** Strutturato



**R50F** Bistrot Crux Grey Soft rettificato  
**R50M** Bistrot Crux Grey Glossy rettificato  
**R50P** Bistrot Crux Grey Strutturato rettificato

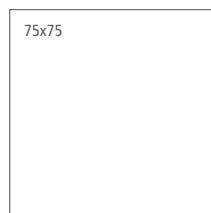

**R4US** Bistrot Crux Grey Soft rettificato  
**R4LP** Bistrot Crux Grey Glossy rettificato

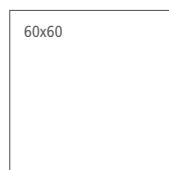

**R4UU** Bistrot Crux Grey Soft rettificato  
**R4RS** Bistrot Crux Grey Glossy rettificato

## Augustus



- G** Soft
- F** Glossy

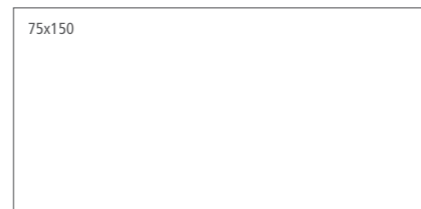

**RG9Y** Bistrot Augustus Soft rettificato  
**RG9W** Bistrot Augustus Glossy rettificato

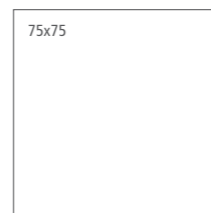

**RGAO** Bistrot Augustus Soft rettificato  
**RGAZ** Bistrot Augustus Glossy rettificato

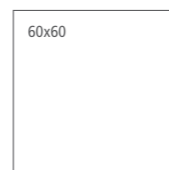

**RG9R** Bistrot Augustus Soft rettificato  
**RG9N** Bistrot Augustus Glossy rettificato



**RG4** Bistrot Augustus Soft rettificato

## Grafite



- H** Soft
- F** Glossy



**R5WF** Bistrot Grafite Soft rettificato  
**R5WP** Bistrot Grafite Glossy rettificato

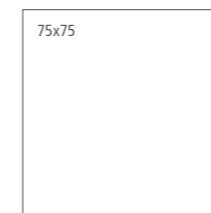

**R5WK** Bistrot Grafite Soft rettificato  
**R5WT** Bistrot Grafite Glossy rettificato

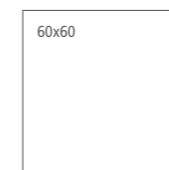

**R5X6** Bistrot Grafite Soft rettificato  
**R5X2** Bistrot Grafite Glossy rettificato

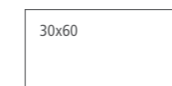

**R5XD** Bistrot Grafite Soft rettificato

## Emperador

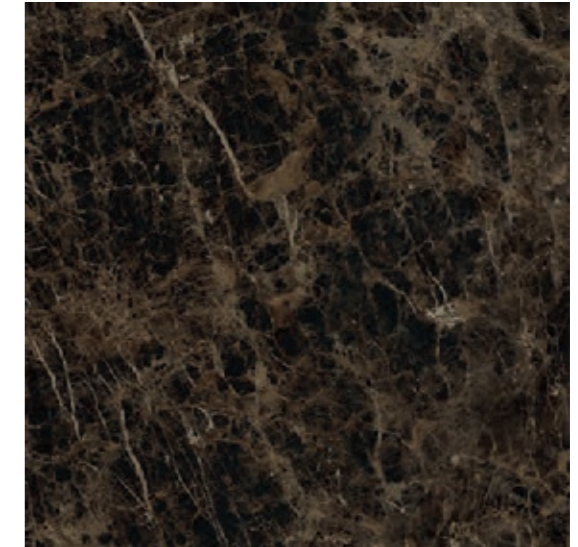

- F** Glossy



**R5WN** Bistrot Emperador Glossy rettificato

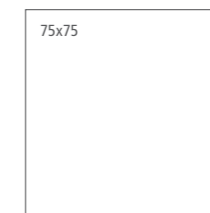

**R5WS** Bistrot Emperador Glossy rettificato

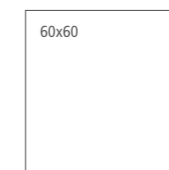

**R5WZ** Bistrot Emperador Glossy rettificato

# Bistrot

75x150 75x75 60x60 30x60 21x18,2 7x28

gres fine porcellanato colorato in massa - rettificato monocalibro / colorbody fine porcelain stoneware - rectified monocaliber / durchgefärbtes feinsteinzeug - rektifiziert, in einem werkmaß / grès cérame fin coloré dans la masse - rectifié monocalibre / gres porcelánico fino coloreado en toda la masa - rectificado monocalibre / гомогенный мелкозернистый керамогранит - ректифицированный монокалиберный

21x18,2 - 7x28

gres porcellanato / porcelain stoneware / feinsteinzeug / grès cérame émaillé / gres porcelánico / керамогранит

superfici / surfaces / finitions / oberflächen / superficies / поверхности:  
naturale/matt + glossy + outdoor

## Infinity



- H Soft
- F Glossy
- H Strutturato

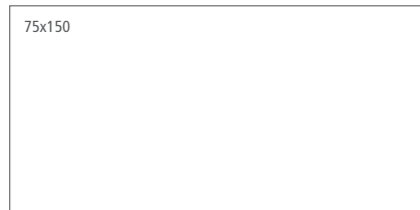

**R50G** Bistrot Infinity Soft rettificato  
**R50N** Bistrot Infinity Glossy rettificato  
**R50Q** Bistrot Infinity Strutturato rettificato

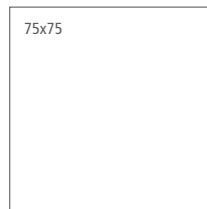

**R4RQ** Bistrot Infinity Soft rettificato  
**R4RL** Bistrot Infinity Glossy rettificato

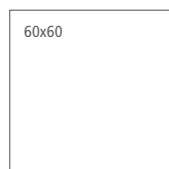

**R4RU** Bistrot Infinity Soft rettificato  
**R4RT** Bistrot Infinity Glossy rettificato

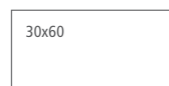

**R4SP** Bistrot Infinity Soft rettificato

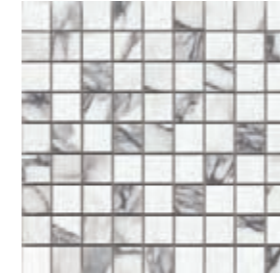

**R7QQ** Bistrot Mosaico Paonazetto\*\*  
**R7QN** Bistrot Mosaico Paonazetto Glossy\*\*  
30x30

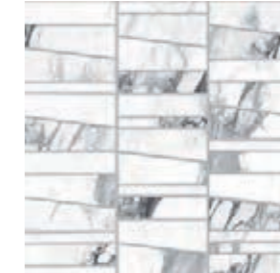

**R7WU** Bistrot Mosaico Trapezi Paonazetto Glossy\*  
30x30

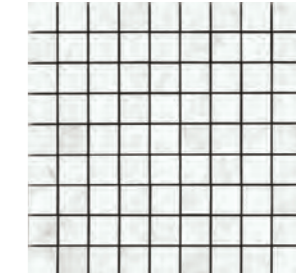

**R4ZL** Bistrot Mosaico Pietrasanta Soft\*  
30x30

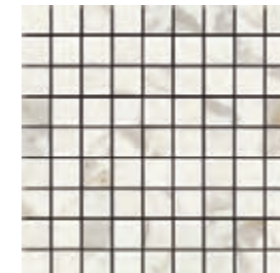

**R4ZM** Bistrot Mosaico Calacatta Michelangelo Soft\*  
30x30

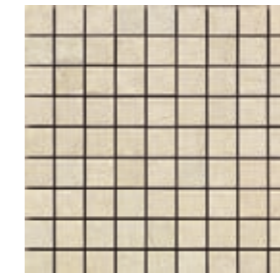

**R4ZK** Bistrot Mosaico Marfil Soft\*  
30x30

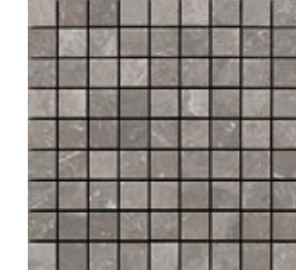

**R4ZQ** Bistrot Mosaico Crux Taupe Soft\*  
30x30

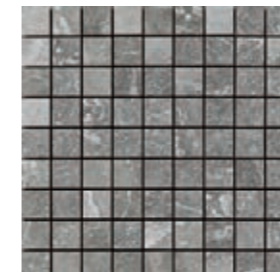

**R4ZR** Bistrot Mosaico Crux Grey Soft\*  
30x30

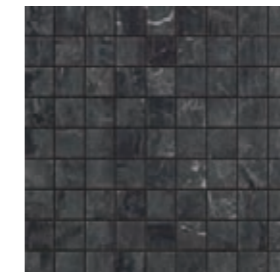

**R4ZS** Bistrot Mosaico Infinity Soft\*  
30x30

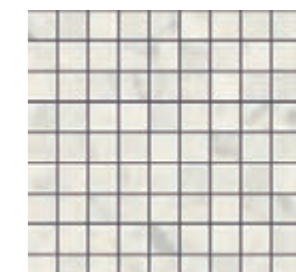

**R65S** Bistrot Mosaico Statuario Soft 30x30\*\*  
**R65W** Bistrot Mosaico Statuario Glossy 30x30\*\*

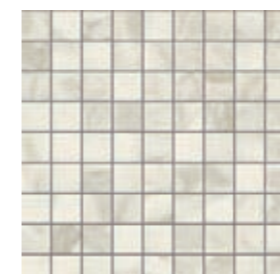

**R65R** Bistrot Mosaico Arabescato Soft 30x30\*\*  
**R65V** Bistrot Mosaico Arabescato Glossy 30x30\*\*

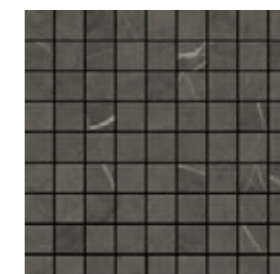

**R65T** Bistrot Mosaico Grafite Soft 30x30\*\*  
**R65Y** Bistrot Mosaico Grafite Glossy 30x30\*\*

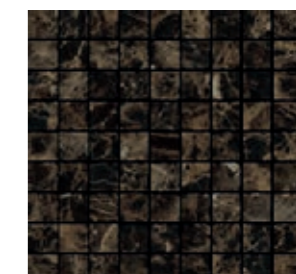

**R65X** Bistrot Mosaico Emperador Glossy 30x30\*\*

# Bistrot

75x150 75x75 60x60 30x60 21x18,2 7x28

gres fine porcellanato colorato in massa - rettificato monocalibro / colorbody fine porcelain stoneware - rectified monocaliber / durchgefärbtes feinsteinzeug - rektifiziert, in einem werkmaß / grès cérame fin coloré dans la masse - rectifié monocalibre / gres porcelánico fino coloreado en toda la masa - rectificado monocalibre / гомогенный мелкозернистый керамогранит - ректифицированный монокалиберный

21x18,2 - 7x28

gres porcellanato / porcelain stoneware / feinsteinzeug / grès cérame émaillé / gres porcelánico / керамогранит

superfici / surfaces / finitions / oberflächen / superficies / поверхности:  
naturale/matt + glossy + outdoor

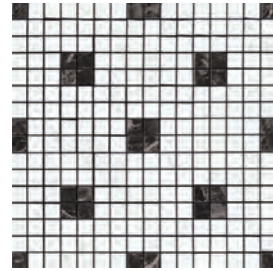

**R4ZH** Bistrot Mosaico Pietrasanta Glossy\*  
30x30

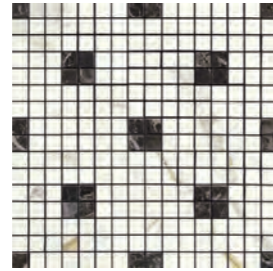

**R4ZJ** Bistrot Mosaico Calacatta Michelangelo Glossy\*  
30x30

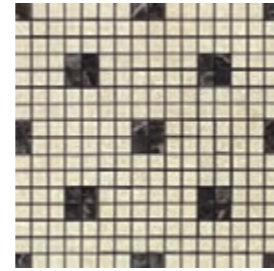

**R4ZN** Bistrot Mosaico Marfil Glossy\*  
30x30

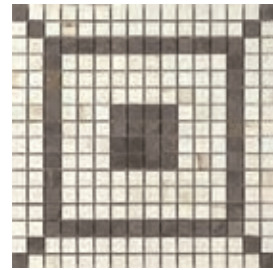

**RKU9** Bistrot Mosaico Decor Crema Delicata Glossy\*  
30x30

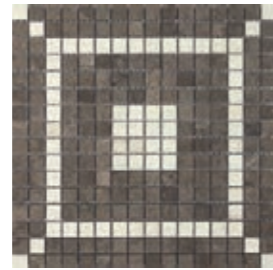

**RKU8** Bistrot Mosaico Decor Augustus Glossy\*  
30x30



**RKU7** Bistrot Mosaico Brick Crema Delicata Soft\*  
30x30



**RKU5** Bistrot Mosaico Brick Augustus Soft\*  
30x30

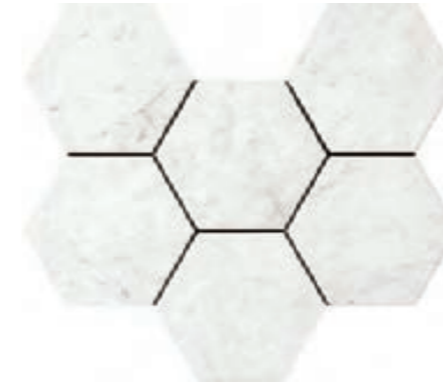

**R4SZ** Bistrot Pietrasanta  
21x18,2

G



**R4TA** Bistrot Calacatta Michelangelo  
21x18,2

G



**R4TC** Bistrot Marfil  
21x18,2

G



**R4TD** Bistrot Crux Taupe  
21x18,2

H



**R4TE** Bistrot Crux Grey  
21x18,2

H



**R4TF** Bistrot Infinity  
21x18,2

G

# Bistrot

75x150 75x75 60x60 30x60 21x18,2 7x28

gres fine porcellanato colorato in massa - rettificato monocalibro / colorbody fine porcelain stoneware - rectified monocalibre / durchgefärbtes feinsteinzeug - rektifiziert, in einem werkmaß / grès cérame fin coloré dans la masse - rectifié monocalibre / gres porcelánico fino coloreado en toda la masa - rectificado monocalibre / гомогенный мелкозернистый керамогранит - ректифицированный монокалиберный

21x18,2 - 7x28

gres porcellanato / porcelain stoneware / feinsteinzeug / grès cérame émaillé / gres porcelánico / керамогранит

superfici / surfaces / finitions / oberflächen / superficies / поверхности:  
naturale/matt + glossy + outdoor



R45S Bistrot Pietrasanta  
7x28



R45T Bistrot Calacatta Michelangelo  
7x28



R45U Bistrot Marfil  
7x28



R45W Bistrot Crux Taupe  
7x28

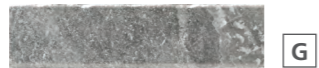

R45X Bistrot Crux Grey  
7x28



R45Y Bistrot Infinity  
7x28



R4YP Bistrot Decoro Pietrasanta  
21x18,2



R4YQ Bistrot Decoro Calacatta Michelangelo  
21x18,2



R4YR Bistrot Decoro Marfil  
21x18,2

Per le pavimentazioni esterne non protette, Ragno consiglia di creare una pendenza  $\geq 1,5\%$  sulla superficie calpestabile allo scopo di limitare il formarsi di ristagni d'acqua localizzati. Nel caso in cui questi ristagni permangano sulla superficie delle piastrelle nonostante una posa a regola d'arte, è necessario intervenire meccanicamente con l'utilizzo di scope o aspira-liquidi. / For unprotected outdoor pavings, Ragno recommends the creation of a gradient of  $\geq 1.5\%$  on the finished surface, to prevent the formation of patches of standing water. In the event that standing water persists on the surface of the tiles in spite of correct installation, it must be removed mechanically with the aid of brooms or wet-and-dry vacuum cleaners. / Zur Unterbindung von punktueller Stauwasserbildung bei Belägen in ungeschützten Außenbereichen, empfiehlt die Ragno die Ausbildung eines Gefälles  $\geq 1,5\%$  auf der Trittläche. Sollte trotz fachgerechter Verlegung Stauwasser auf der Fliesenoberfläche zurückbleiben, ist dessen mechanische Entfernung mit Hilfe eines Besens oder Nasssaugers erforderlich. / Pour des sols extérieurs non protégés, Ragno conseille de créer une inclinaison  $\geq 1,5\%$  sur la surface de piétinement en vue de limiter la stagnation localisée de l'eau. Si, malgré une pose dans les règles de l'art, cette stagnation devait persister à la surface des carreaux, une intervention mécanique, au moyen de balais et d'aspirateurs de liquides, est alors nécessaire. / En el caso de pavimentaciones exteriores no protegidas, Ragno recomienda crear una pendiente  $\geq 1,5\%$  en la superficie transitable para limitar la formación de depósitos localizados de agua estancada. En caso de que estos depósitos de agua permanezcan en la superficie del azulejo, aun cuando la colocación se haya realizado correctamente, será necesario intervenir mecánicamente empleando un cepillo o un aspirador de líquidos. / Для наружных незащищенных полов Ragno рекомендует создавать уклон  $\geq 1,5\%$  на пешеходной поверхности для снижения образования локальных застоев воды. В случае, если застои воды образуются на плитке несмотря на правильную укладку, необходимо прибегать к использованию механических средств, таких как щетки или же аппараты для сбора жидкостей.

## tech info



Mosaico assemblato su rete in fibra di vetro / Mosaic mesh - mounted on fibreglass / Auf Glasfasernetz geklebtes Mosaik / Mosaïque montée sur filet en fibre de verre / Mosaico enmallado sobre fibra de vidrio / Мозаика, собранная на сетке из стекловолокна

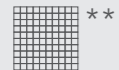

Mosaico assemblato con tratto plastico / Spot-bonded mosaic / Punktverklebtes Mosaik / Mosaïque montée avec trait de colle / Mosaico colocado aplicando cola plástica / Мозаика с сегментами, выполненными из пластмассы - Мозаика, собранная на клеевой точке

\*\*\*

Battiscopa ottenuto da taglio del fondo / Skirting cut from plain tile / Aus Grundfliese geschchnittener Sockel / Plinthe obtenue par découpe du fond / Rodapié obtenido mediante corte del fondo / Плинтус, полученный методом нарезания фоновой плитки



Vedi Appendice pag. 585  
See Appendix page 585  
Siehe Anhang S. 585  
Voir Annexe page 585  
Véase la pág. 585 del Apéndice  
Смотри приложение на стр. 585



Apprezzabili differenze nell'aspetto di superficie e grafica all'interno della stessa produzione. / Clearly distinguishable differences in texture and pattern within the same production run. / Auffällige Unterschiede in Aussehen und Struktur innerhalb der gleichen Produktionscharge. / Différences visibles au niveau de l'aspect et de la fantaisie entre les carreaux du même lot de production. / Diferencias visibles en el aspecto de la superficie y los motivos dentro de un mismo lote de producción. / Заметные отличия вида поверхности и графики в одной и той же партии.



Significativa variazione di aspetto superficiale, grafica e colore da piastrella a piastrella e all'interno della stessa piastrella. Si consiglia di visionare la gamma cromatica prima della selezione del materiale. / Significant variation in texture, pattern and colour from tile to tile within the same production run. The colour range should be viewed before selecting the material. / Bedeutende Variation in Aussehen, Struktur und Farbe von Fliese zu Fliese und in ein und derselben Fliese. Es wird empfohlen, das Farbsortiment vor der Auswahl des Materials zu prüfen. / Variation significative au niveau de l'aspect, de la fantaisie et de la couleur entre les carreaux et au sein d'un même carreau. Il est recommandé de consulter la gamme des couleurs avant de sélectionner le matériel. / Variación considerable en el aspecto superficial, los motivos y el color entre un azulejo y otro y dentro del propio azulejo. Es aconsejable visualizar la gama cromática antes de seleccionar el material. / Значительные отличия вида поверхности, графики и цвета у разных плиток и на одной и той же плитке. Перед отбором материала рекомендуется посмотреть цветовую гамму.



Variazioni irregolari da piastrella a piastrella. Una piastrella può differire totalmente nell'aspetto superficiale e colore da un'altra. Si consiglia di visionare la gamma cromatica prima della selezione del materiale. / Random differences from tile to tile. One tile may have totally different texture and colour from another. The colour range should be viewed before selecting the material. / Wesentliche Variationen von Fliese zu Fliese. Eine Fliese kann sich in Aussehen und Farbe komplett von einer anderen unterscheiden. Es wird empfohlen, das Farbsortiment vor der Auswahl des Materials zu prüfen. / Variations irrégulières entre les carreaux. L'aspect et la couleur peuvent être complètement différents d'un carreau à l'autre. Il est recommandé de consulter la gamme des couleurs avant de sélectionner le matériel. / Variaciones irregulares entre un azulejo y otro. Un azulejo puede ser completamente diferente de otro en el aspecto superficial y el color. Es aconsejable visualizar la gama cromática antes de seleccionar el material. / Неоднородные изменения на разных плитках. Каждая плитка может полностью отличаться по виду поверхности и цвету от другой. Перед отбором материала рекомендуется посмотреть цветовую гамму.

## pezzi speciali / trims / spezialteile / pièces spéciales / piezas especiales / специальные изделия



BT.B.C. \*\*\*  
7x60



BT.B.C. Glossy\*\*\*  
7x60

Bistrot Paonazzetto	R7QE	R7QL
Bistrot Pietrasanta	R4VK	R4VS
Bistrot Statuario	R6WE	R6WM
Bistrot Arabescato	R6WC	R6WK
Bistrot Calacatta Michelangelo	R4VL	R4VT
Bistrot Crema Delicato	RGLD	RGLH
Bistrot Marfil	R4VM	R4VU
Bistrot Crux Taupe	R4VP	R4VV
Bistrot Augustus	RGLC	RGLG
Bistrot Emperador	-	R6WP
Bistrot Grafite	R6WG	R6WR
Bistrot Crux Grey	R4VQ	R4VW
Bistrot Infinity	R4VR	R4VX



BT.B.C. \*\*\*  
7x75



BT.B.C. Glossy\*\*\*  
7x75

Bistrot Paonazzetto	R7QG	R7QJ
Bistrot Pietrasanta	R50V	R51C
Bistrot Statuario	R6VH	R6VU
Bistrot Arabescato	R6VF	R6VS
Bistrot Calacatta Michelangelo	R50W	R51D
Bistrot Crema Delicato	RGLF	RGLK
Bistrot Marfil	R50X	R51E
Bistrot Crux Taupe	R50Z	R51F
Bistrot Augustus	RGLE	RGLJ
Bistrot Emperador	-	R6VW
Bistrot Grafite	R6VN	R6VY
Bistrot Crux Grey	R51A	R51G
Bistrot Infinity	R50Y	R51H

## imballi / packaging / verpackungen / emballages / embalajes / упаковки

Scatole / Box / Karton / Boite / Caja / Коробки

Pallet / Pallet / Palette / Palette / Pallet / Поддон



fondi / plain tiles / grundfliesen / fonds / fondos / фоновая плитка	Box / Karton / Boite / Caja / Коробки	Pallet / Pallet / Palette / Palette / Pallet / Поддон	# mm
75x150 paonazzetto / soft / strut.	2, 2,25	55,16	21 47,25 1158,37 10,5
75x150 glossy	2	2,25 55,89	21 47,25 1173,62 10,5
75x75	2	1,13 23,81	42 47,25 1000,00 9,5
75x75 glossy	2	1,13 23,81	42 47,25 1000,00 9,5
60x60 paonazzetto / soft	3	1,08 22,67	40 43,20 906,99 9,5
60x60 glossy	3	1,08 26,21	40 43,20 1048,54 10
30x60 paonazzetto / soft	6	1,08 21,51	48 51,84 1032,26 9,5
21x18,2	16	0,46 9,30	100 45,86 930,33 9,5
7x28	50	0,98 19,18	52 50,96 997,11 9

decori / decorative pieces / dekore / décors / decoraciones / декоры	Box / Karton / Boite / Caja / Коробки	Pallet / Pallet / Palette / Palette / Pallet / Поддон	# mm
30x30 mosaico paonazz. / soft	4	0,36 7,50	9,5
30x30 mosaico glossy	4	0,36 7,50	9,5
30x30 mosaico trapezi	4	0,36 7,00	9,5
30x30 mosaico brick soft	4	0,36 10,00	9,5
30x30 mosaico decor glossy	4	0,36 7,50	9,5
21x18,2decoro	16	0,46 9,52	100 45,86 952,85 9,5

pezzi speciali / trims / spezialteile / pièces spéciales / piezas especiales / специальные изделия	Box / Karton / Boite / Caja / Коробки	Pallet / Pallet / Palette / Palette / Pallet / Поддон	# mm
7x75 BT.B.C. paonazzetto	14	10,5 ml 20,00	9,5
7x75 BT.B.C. soft	13	9,75 ml 17,45	9,5
7x75 BT.B.C. glossy	14	10,5 ml 18,57	9,5
7x60 BT.B.C. paonazz. - soft	15	9,00 ml 14,43	9,5
7x60 BT.B.C. glossy	14	8,40 ml 14,88	10

# Imperiale

60x120 58x116 60x60 58x58



R732 Imperiale Travertino Grigio glossy rettificato 58x58

# Imperiale

60x120 58x116 60x60 58x58



gres porcellanato - rettificato monocalibro / porcelain stoneware - rectified monocaliber / feinsteinzeug - rektifiziert, in einem werkmaß / grès cérame émaillé - rectifié monocalibre / gres porcelánico - retificado monocalibre / керамогранит - ректифицированный монокалиберный

superfici / surfaces / finitions / oberflächen / superficies / поверхности: naturale/matt + glossy

marble effect



**H** Naturale/Matt  
**F** Glossy

60x120 Naturale/Matt  
58x116 Glossy

**R72P** Imperiale Bianco rettificato  
**R70Z** Imperiale Bianco Glossy rettificato

60x60 Naturale/Matt  
58x58 Glossy

**R738** Imperiale Bianco rettificato  
**R72W** Imperiale Bianco Glossy rettificato



**H** Naturale/Matt  
**F** Glossy

60x120 Naturale/Matt  
58x116 Glossy

**R72Q** Imperiale Venato rettificato  
**R710** Imperiale Venato Glossy rettificato

60x60 Naturale/Matt  
58x58 Glossy

**R739** Imperiale Venato rettificato  
**R72X** Imperiale Venato Glossy rettificato

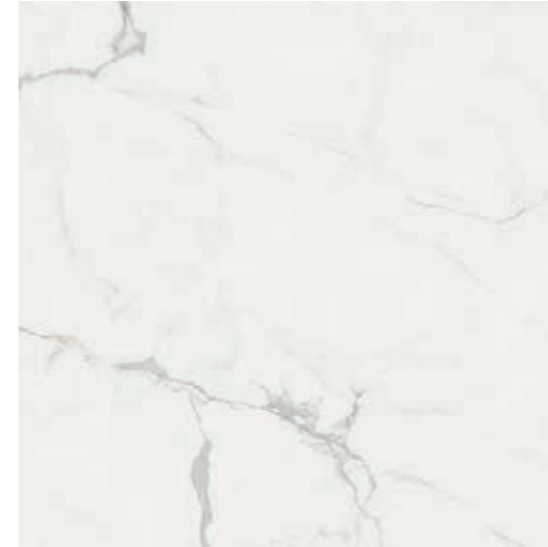

**H** Naturale/Matt  
**F** Glossy

60x120 Naturale/Matt  
58x116 Glossy

**R72R** Imperiale Statuarietto rettificato  
**R72G** Imperiale Statuarietto Glossy rettificato

60x60 Naturale/Matt  
58x58 Glossy

**R73A** Imperiale Statuarietto rettificato  
**R72Y** Imperiale Statuarietto Glossy rettificato



**H** Naturale/Matt  
**F** Glossy

58x116 Glossy

**R72H** Imperiale Calacatta Glossy rettificato

60x60 Naturale/Matt  
58x58 Glossy

**R73C** Imperiale Calacatta rettificato  
**R72Z** Imperiale Calacatta Glossy rettificato

# Imperiale

60x120 58x116 60x60 58x58

gres porcellanato - rettificato monocalibro / porcelain stoneware - rectified monocaliber / feinsteinzeug - rektifiziert, in einem werkmaß / grès cérame émaillé - rectifié monocalibre / gres porcelánico - rectificado monocalibre / керамогранит - ректифицированный монокалиберный

superfici / surfaces / finitions / oberflächen / superficies / поверхности: naturale/matt + glossy

marble effect



**H** Naturale/Matt  
**F** Glossy

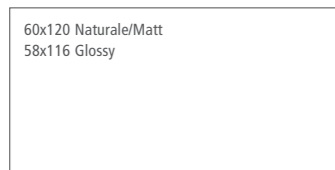

**R72S** Imperiale Avorio rettificato  
**R72J** Imperiale Avorio Glossy rettificato



**H** Naturale/Matt  
**F** Glossy

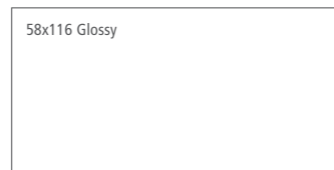

**R72K** Imperiale Travertino Glossy rettificato



**R73D** Imperiale Avorio rettificato  
**R730** Imperiale Avorio Glossy rettificato

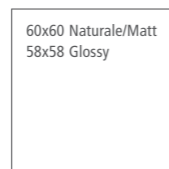

**R73E** Imperiale Travertino rettificato  
**R731** Imperiale Travertino Glossy rettificato



**H** Naturale/Matt  
**F** Glossy

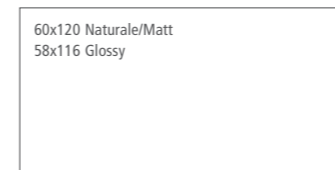

**R72T** Imperiale Travertino Grigio rettificato  
**R72L** Imperiale Travertino Grigio Glossy rettificato



**R73F** Imperiale Travertino Grigio rettificato  
**R732** Imperiale Travertino Grigio Glossy rettificato



**H** Naturale/Matt  
**F** Glossy

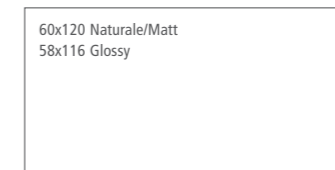

**R72U** Imperiale Crema rettificato  
**R72M** Imperiale Crema Glossy rettificato

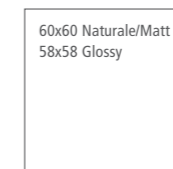

**R73G** Imperiale Crema rettificato  
**R734** Imperiale Crema Glossy rettificato

## tech info

★  
Battiscopa ottenuto da taglio del fondo / Skirting cut from plain tile / Aus Grundfliese geschnittener Sockel / Plinthe obtenue par découpe du fond / Rodapié obtenido mediante corte del fondo / Плинтус, полученный методом нарезания фоновой плитки



Apprezzabili differenze nell'aspetto di superficie e grafica all'interno della stessa produzione. / Clearly distinguishable differences in texture and pattern within the same production run. / Auffällige Unterschiede in Aussehen und Struktur innerhalb der gleichen Produktionscharge. / Différences visibles au niveau de l'aspect et de la fantaisie entre les carreaux du même lot de production. / Diferencias visibles en el aspecto de la superficie y los motivos dentro de un mismo lote de producción. / Заметные отличия вида поверхности и графики в одной и той же партии.

## pezzi speciali / trims / spezialteile / pièces spéciales / piezas especiales / специальные изделия



Imperiale Bianco	R73J	R742
Imperiale Venato	R73K	R743
Imperiale Statuarietto	R73L	R744
Imperiale Calacatta	R73M	R745
Imperiale Avorio	R73N	R746
Imperiale Travertino	R73P	R748
Imperiale Travertino Grigio	R73Q	R749
Imperiale Crema	R73R	R74A

## imballi / packaging / verpackungen / emballages / embalajes / упаковки

Scatole / Box / Karton / Boîte / Caja / Коробки	Pallet / Pallet / Palette / Palette / Поддон
M <sup>2</sup> KG	M <sup>2</sup> KG # mm

fondi / plain tiles / grundfliesen / fonds / fondos / фоновая плитка								
60x120	rettificato	2	1,44	31,47	36	51,84	1132,85	9,5
58x116	rettificato glossy	2	1,35	31,28	36	48,44	1126,00	9,5
60x60	rettificato	3	1,08	23,31	40	43,20	932,44	9,5
58x58	rettificato glossy	3	1,01	21,71	40	40,37	868,69	9,5

pezzi speciali / trims / spezialteile / pièces spéciales / piezas especiales / специальные изделия								
7x60	BT.B.C.	15	9,00 ml	15,00				9,5
7x58	BT.B.C. glossy	15	8,70 ml	15,57				9,5





## STONE EFFECT

- Gres Effetto Pietra*
- Stone Effect Stoneware*
- Feinsteinzeug in Natursteinoptik*
- Grès Effet Pierre*
- Gres Efecto Piedra*
- Керамогранит под камень*

# Realstone\_Lunar

120x120 75x150 75x75 60x120 60x60 30x60



R7AH Realstone\_Lunar White rettificato 75x150



stone effect

# Realstone\_Lunar

120x120 75x150 75x75 60x120 60x60 30x60



Gruppo Bia UNI EN 14411\_G

gres fine porcellanato colorato in massa - rettificato monocalibro / colorbody fine porcelain stoneware - rectified monocaliber / durchgefärbtes feinsteinzeug - rektifiziert, in einem werkmaß / grès cérame fin coloré dans la masse - rectifié monocalibre / gres porcelánico fino coloreado en toda la masa - rectificado monocalibre / гомогенный мелкозернистый керамогранит - ректифицированный монокалиберный

superfici / surfaces / finitions / oberflächen / superficies / поверхности:  
naturale/matt + outdoor

Stepwise



H



R7AH Lunar White rettificato



H

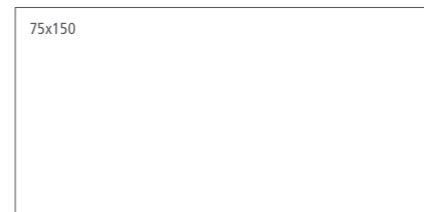

R7AJ Lunar Beige rettificato

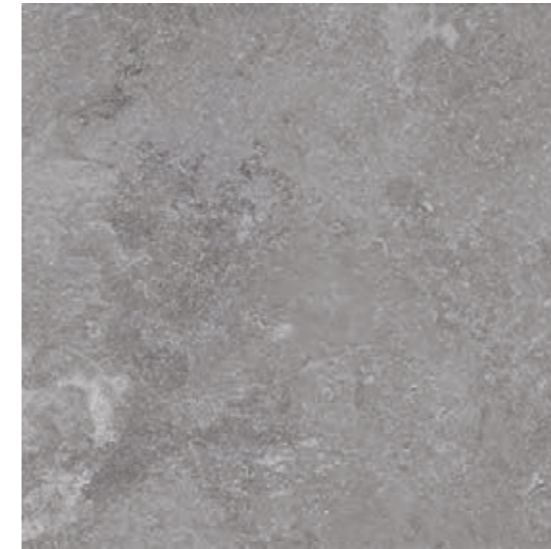

H



R7AF Lunar Silver rettificato

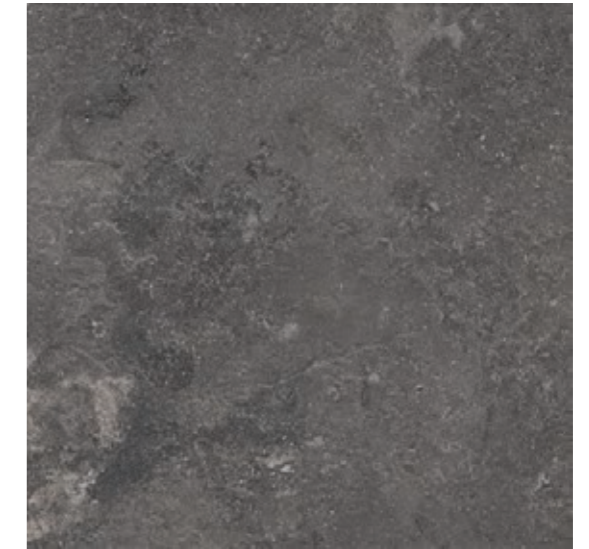

H



R7AG Lunar Deep Grey rettificato

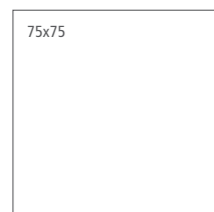

R7AP Lunar White rettificato



R7AV Lunar White rettificato  
R7CQ Lunar White strutturato rettificato

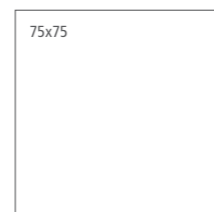

R7AQ Lunar Beige rettificato



R7AW Lunar Beige rettificato  
R7CR Lunar Beige strutturato rettificato

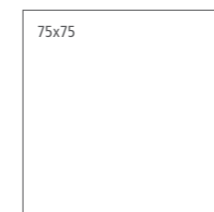

R7AM Lunar Silver rettificato



R7AT Lunar Silver rettificato  
R7CN Lunar Silver strutturato rettificato

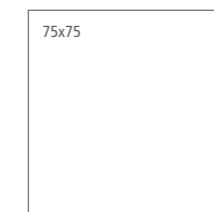

R7AN Lunar Deep Grey rettificato



R7AU Lunar Deep Grey rettificato  
R7CP Lunar Deep Grey strutturato rettificato

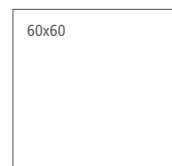

R7CC Lunar White rettificato

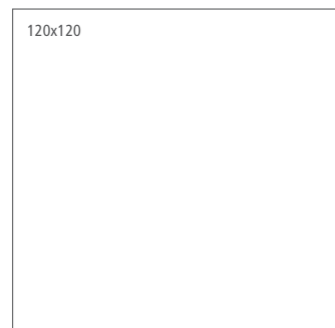

R8DH Lunar White rettificato

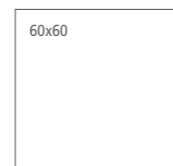

R7CD Lunar Beige rettificato



R8DM Lunar Beige rettificato

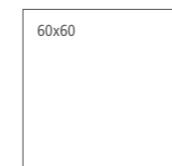

R7AZ Lunar Silver rettificato



R8DJ Lunar Silver rettificato

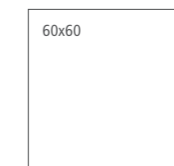

R7CA Lunar Deep Grey rettificato



R7CH Lunar Deep Grey rettificato  
R8DK Lunar Deep Grey rettificato



R7CJ Lunar White rettificato  
R7CW Lunar White strutturato rettificato



R7CK Lunar Beige rettificato  
R7CX Lunar Beige strutturato rettificato



R7CG Lunar Silver rettificato  
R7CU Lunar Silver strutturato rettificato



R7CH Lunar Deep Grey rettificato  
R7CV Lunar Deep Grey strutturato rettificato

stone effect

# Realstone\_Lunar

120x120 75x150 75x75 60x120 60x60 30x60

Gruppo Bia UNI EN 14411\_G

gres fine porcellanato colorato in massa - rettificato monocoloro / colorbody fine porcelain stoneware - rectified monocolor / durchgefärbtes feinsteinzeug - rektifiziert, in einem werkmaß / grès cérame fin coloré dans la masse - rectifié monocolor / gres porcelánico fino coloreado en toda la masa - rectificado monocolor / гомогенный мелкозернистый керамогранит - ректифицированный монокалиберный

superfici / surfaces / finitions / oberflächen / superficies / поверхности:  
naturale/matt + outdoor

Stepwise

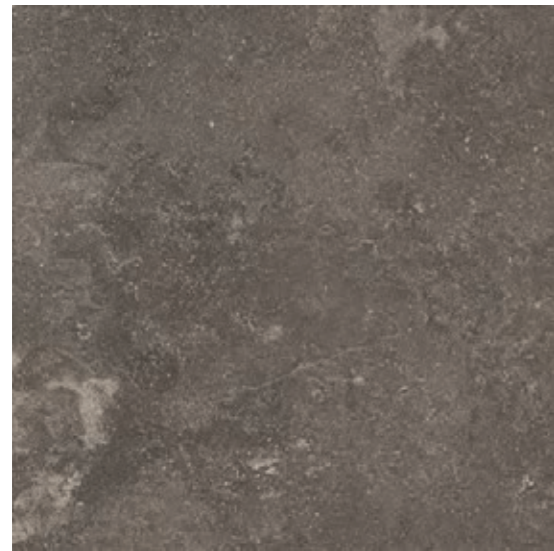

H



R7AK Lunar Uniform rettificato

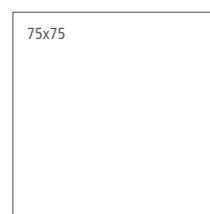

R7AR Lunar Uniform rettificato



R7AX Lunar Uniform rettificato  
R7CS Lunar Uniform strutturato rettificato

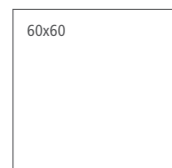

R7CE Lunar Uniform rettificato

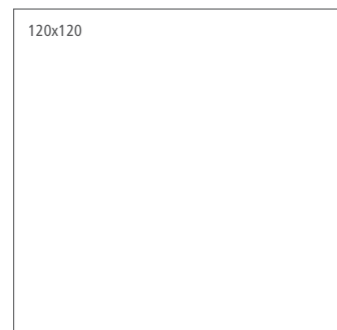

R8DL Lunar Uniform rettificato

R7CL Lunar Uniform rettificato  
R7CY Lunar Uniform strutturato rett.

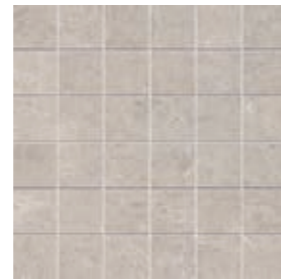

R7NG Lunar Mosaico White  
30x30



R7NH Lunar Mosaico Beige  
30x30



R7NJ Lunar Mosaico Silver  
30x30

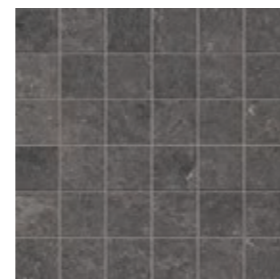

R7NK Lunar Mosaico Deep Grey  
30x30



R7NL Lunar Mosaico Uniform  
30x30



R7XK Lunar Mosaico 3D White  
29x33,5



R7XL Lunar Mosaico 3D Beige  
29x33,5



R7XM Lunar Mosaico 3D Silver  
29x33,5

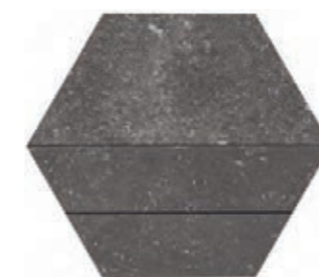

R7XN Lunar Mosaico 3D Deep Grey  
29x33,5

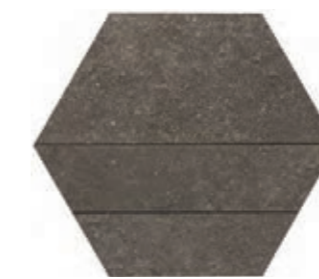

R7XQ Lunar Mosaico 3D Uniform  
29x33,5



Mosaico assemblato con tratto plastico / Spot-bonded mosaic / Punktverklebtes Mosaik / Mosaïque montée avec trait de colle / Mosaico colocado aplicando cola plástica / Мозаика с сегментами, выполненными из пластмассы - Мозаика, собранная на клеевой точке

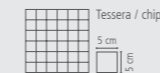

Mosaico assemblato su rete in fibra di vetro / Mosaic mesh - mounted on fibreglass / Auf Glasfasernetz geklebtes Mosaik / Mosaïque montée sur filet en fibre de verre / Mosaico enmallado sobre fibra de vidrio / Мозаика, собранная на сетке из стекловолокна



Apprezzabili differenze nell'aspetto di superficie e grafica all'interno della stessa produzione. / Clearly distinguishable differences in texture and pattern within the same production run. / Auffällige Unterschiede in Aussehen und Struktur innerhalb der gleichen Produktionscharge. / Différences visibles au niveau de l'aspect et de la fantaisie entre les carreaux du même lot de production. / Diferencias visibles en el aspecto de la superficie y los motivos dentro de un mismo lote de producción. / Заметные отличия вида поверхности и графики в одной и той же партии.

Battiscopa ottenuto da taglio del fondo / Skirting cut from plain tile / Aus Grundfliese geschnittener Sockel / Plinthe obtenue par découpe du fond / Rodapié obtenido mediante corte del fondo / Плинтус, полученный методом нарезания фоновой плитки

Assemblato / Two-piece L-tile / Randstein zweiteilig / Assemblé / Montado / Собранный

pezzi speciali / trims / spezialteile / pièces spéciales / piezas especiales / специальные изделия

	BT.B.C.* 7x60	BT.B.C.* 7x75
Lunar White	R7NN	R7NZ
Lunar Beige	R7NP	R7P1
Lunar Silver	R7NR	R7PA
Lunar Deep Grey	R7NU	R7PC
Lunar Uniform	R7NV	R7PD

	E.ELLE strutt.** 15x60x4	E.ELLE strutt.** 15x120x4
Lunar White	R7PG	R7PP
Lunar Beige	R7PH	R7PR
Lunar Silver	R7PJ	R7PS
Lunar Deep Grey	R7PK	R7PU
Lunar Uniform	R7PL	R7PV

imballi / packaging / verpackungen / emballages / embalajes / упаковки

	Scatole / Box / Karton / Boîte / Caja / Коробки	Pallet / Pallet / Palette / Palette / Поддон
	M2	KG

	fondi / plain tiles / grundfliesen / fonds / fondos / фоновая плитка
75x150	rettificato 2 2,25 51,81 21 47,25 1088,00 9,5
75x75	rettificato 2 1,13 23,81 42 47,25 1000,00 9,5
120x120	rettificato 1 1,44 37,99 36 51,84 1367,80 10
60x120	rett. / strutt. 2 1,44 31,47 36 51,84 1132,85 9,5
60x60	rettificato 3 1,08 22,50 40 43,20 900,00 9,5
30x60	rett. / strutt. 6 1,08 23,04 48 51,84 1105,80 9,5

	pezzi speciali / trims / spezialteile / pièces spéciales / piezas especiales / специальные изделия
15x120x4	E.ELLE 2 0,36 20,60
15x60x4	E.ELLE 4 0,36 7,00
7x75	BT.B.C. 14 10,50 ml 20,00 9,5
7x60	BT.B.C. 14 8,40 ml 12,00 9,5

# Realstone\_Navigli

75x150 75x75 60x60 30x60



R7JA Realstone\_Navigli Grigio rettificato 75x75  
R7MA Realstone\_Navigli Mosaico 3D Grigio 30x30

stone effect

# Realstone\_Navigli

75x150 75x75 60x60 30x60

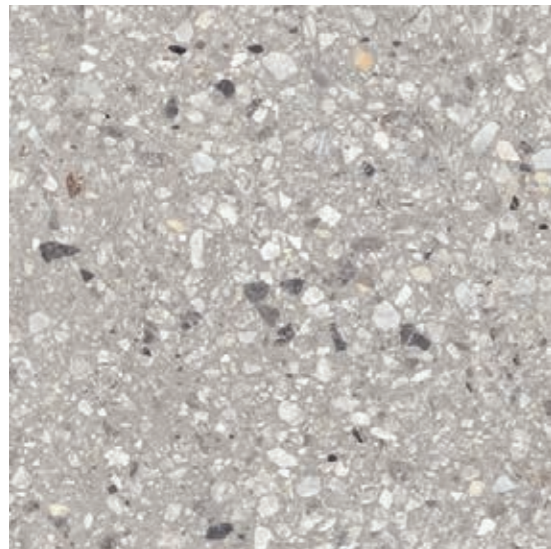

H



**R7HW** Navigli Grigio rettificato

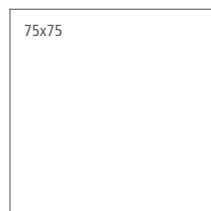

**R7JA** Navigli Grigio rettificato  
**R7JL** Navigli Grigio strutturato rettificato

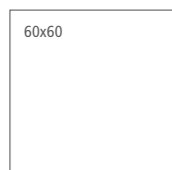

**R7JT** Navigli Grigio rettificato



**R7JW** Navigli Grigio rettificato  
**R7JP** Navigli Grigio strutturato rettificato

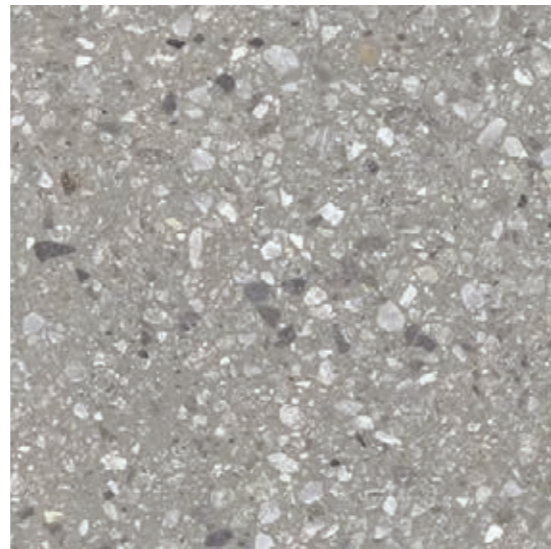

H



**R7HY** Navigli Naturale rettificato

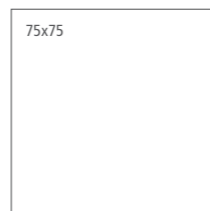

**R7JC** Navigli Naturale rettificato  
**R7JM** Navigli Naturale strutturato rettificato

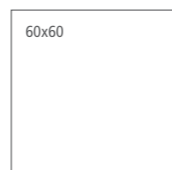

**R7JU** Navigli Naturale rettificato



**R7JX** Navigli Naturale rettificato  
**R7JQ** Navigli Naturale strutturato rettificato

gres fine porcellanato colorato in massa - rettificato monocalibro / colorbody fine porcelain stoneware - rectified monocaliber / durchgefärbtes feinsteinzeug - rektifiziert, in einem werkmaß / grès cérame fin coloré dans la masse - rectifié monocalibre / gres porcelánico fino coloreado en toda la masa - rectificado monocalibre / гомогенный мелкозернистый керамогранит - ректифицированный монокалиберный

superfici / surfaces / finitions / oberflächen / superficies / поверхности:  
**naturale/matt + outdoor**

Stepwise

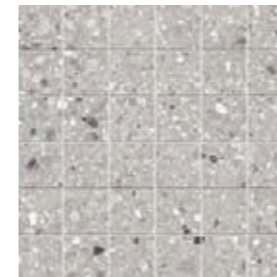

**R7MP** Navigli Mosaico Grigio 30x30

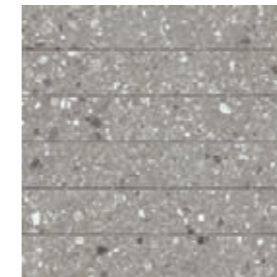

**R7MQ** Navigli Mosaico Naturale 30x30



**R7MA** Navigli Mosaico 3D Grigio 30x30



**R7M7** Navigli Mosaico 3D Naturale 30x30

stone effect

## tech info



Mosaico assemblato con tratto plastico / Spot-bonded mosaic / Punktverklebtes Mosaik / Mosaïque montée avec trait de colle / Mosaico colocado aplicando cola plástica / Мозаика с сегментами, выполненными из пластмассы - Мозаика, собранная на клеевой точке

\*

Battiscopa ottenuto da taglio del fondo / Skirting cut from plain tile / Aus Grundfliese geschnittener Sockel / Plinthe obtenue par découpe du fond / Rodapié obtenido mediante corte del fondo / Плинтус, полученный методом нарезания фоновой плитки



Apprezzabili differenze nell'aspetto di superficie e grafica all'interno della stessa produzione. / Clearly distinguishable differences in texture and pattern within the same production run. / Auffällige Unterschiede in Aussehen und Struktur innerhalb der gleichen Produktionscharge. / Différences visibles au niveau de l'aspect et de la fantaisie entre les carreaux du même lot de production. / Diferencias visibles en el aspecto de la superficie y los motivos dentro de un mismo lote de producción. / Заметные отличия вида поверхности и графики в одной и той же партии.

\*\*

Assemblato / Two-piece L-tile / Randstein zweiteilig / Assemblé / Montado / Собранная

pezzi speciali / trims / spezialteile / pièces spéciales / piezas especiales / специальные изделия

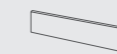

BT.B.C.\*  
7x60



BT.B.C.\*  
7x75

Navigli Grigio	R7MH	R7ML
Navigli Naturale	R7MJ	R7MM

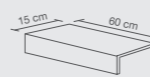

E.ELLE strutt. \*\*  
15x60x4

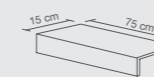

E.ELLE strutt. \*\*  
15x75x4

Navigli Grigio	R7MS	R7MV
Navigli Naturale	R7MT	R7MW

imballi / packaging / verpackungen / emballages / embalajes / упаковки

Scatole / Box / Karton / Boite / Caja / Коробки	M <sup>2</sup>	KG	Pallet / Pallet / Palette / Palette / Pallet / Поддон	M <sup>2</sup>	KG	mm
---	----------------	----	---	----------------	----	----

fondi / plain tiles / grundfliesen / fonds / fondos / фоновая плитка	75x150	75x75	60x60	30x60
rettificato	2, 2,25	2, 1,13	3, 1,08	6, 1,08
rett. / strutt.	2, 2,25	2, 1,13	3, 1,08	6, 1,08
rettificato	21, 47,25	42, 47,25	40, 43,20	48, 51,84
rett. / strutt.	21, 47,25	42, 47,25	40, 43,20	48, 51,84

decori / decorative pieces / dekore / décors / decoraciones / декоры	30x30	30x30
mosaico	4, 0,36	4, 0,36
mosaico 3D	7,91	8,00
	60	21,60
	480,00	9,5

pezzi speciali / trims / spezialteile / pièces spéciales / piezas especiales / специальные изделия	15x75x4	15x60x4	7x75	7x60
E.ELLE	2, 0,23	4, 0,36	14, 10,50 ml	14, 8,40 ml
	10,80	6,12	20,00	12,00
			9,5	9,5

# Realstone\_PietrAntica

60x120 60x60 30x60



stone effect

R78P Realstone\_PietrAntica Multicolor rettificato 60x120  
R78T Realstone\_PietrAntica Multicolor rettificato 60x60  
R78X Realstone\_PietrAntica Multicolor rettificato 30x60  
R7DL Realstone\_PietrAntica Multicolor strutturato rettificato 30x60

# Realstone\_PietrAntica

60x120 60x60 30x60



gres fine porcellanato colorato in massa - rettificato monocalibro / colorbody fine porcelain stoneware - rectified monocaliber / durchgefärbtes feinsteinzeug - rektifiziert, in einem werkmaß / grès cérame fin coloré dans la masse - rectifié monocalibre / gres porcelánico fino coloreado en toda la masa - rectificado monocalibre / гомогенный мелкозернистый керамогранит - ректифицированный монокалиберный

superfici / surfaces / finitions / oberflächen / superficies / поверхности:  
naturale/matt + outdoor

Beige / White Multicolor

naturale   naturale   strutturato   strutturato   naturale   strutturato   strutturato   naturale/strutturato   naturale/strutturato



- G** Smooth
- H** Naturale
- H** Strutturato

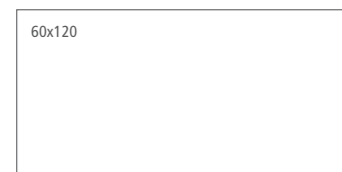

**R78Z** PietrAntica Bianco Smooth rettificato  
**R78M** PietrAntica Bianco rettificato

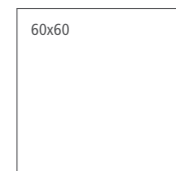

**R793** PietrAntica Bianco Smooth rettificato  
**R78R** PietrAntica Bianco rettificato  
**R7JG** PietrAntica Bianco strutturato rettificato



**R799** PietrAntica Bianco Smooth rettificato  
**R78V** PietrAntica Bianco rettificato  
**R7DJ** PietrAntica Bianco strutturato rettificato



- G** Smooth
- H** Naturale
- H** Strutturato



**R790** PietrAntica Beige Smooth rettificato  
**R78N** PietrAntica Beige rettificato

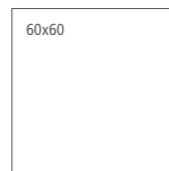

**R794** PietrAntica Beige Smooth rettificato  
**R78S** PietrAntica Beige rettificato  
**R7JH** PietrAntica Beige strutturato rettificato



**R79A** PietrAntica Beige Smooth rettificato  
**R78W** PietrAntica Beige rettificato  
**R7DK** PietrAntica Beige strutturato rettificato



- G** Smooth
- H** Naturale
- H** Strutturato



**R791** PietrAntica Multicolor Smooth rettificato  
**R78P** PietrAntica Multicolor rettificato

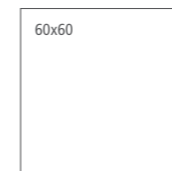

**R795** PietrAntica Multicolor Smooth rettificato  
**R78T** PietrAntica Multicolor rettificato  
**R7JJ** PietrAntica Multicolor strutturato rettificato



**R79C** PietrAntica Multicolor Smooth rettificato  
**R78X** PietrAntica Multicolor rettificato  
**R7DL** PietrAntica Multicolor strutturato rettificato

stone effect



# Realstone\_PietrAntica

60x120 60x60 30x60

Abbinabile ai fondi / Matching with colours / Mit den Grundfliesen kombinierbar / Peut s'associer aux carreaux de base de couleurs / Puede combinarse con los fondos / Сочетается с фоновой плиткой:

Beige



**R7RH** PietrAntica Decoro Cementine Caldi\*  
30x30

Abbinabile ai fondi / Matching with colours / Mit den Grundfliesen kombinierbar / Peut s'associer aux carreaux de base de couleurs / Puede combinarse con los fondos / Сочетается с фоновой плиткой:

Bianco, Multicolor



**R8DF** PietrAntica Decoro Cementine Freddi\*  
30x30

gres fine porcellanato colorato in massa - rettificato monocalibro / colorbody fine porcelain stoneware - rectified monocaliber / durchgefärbtes feinsteinzeug - rektifiziert, in einem werkmaß / grès cérame fin coloré dans la masse - rectifié monocalibre / gres porcelánico fino coloreado en toda la masa - rectificado monocalibre / гомогенный мелкозернистый керамогранит - ректифицированный монокалиберный

superfici / surfaces / finitions / oberflächen / superficies / поверхности:  
**naturale/matt + outdoor**

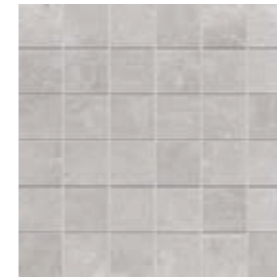

**R7MY** PietrAntica Mosaico Bianco  
30x30

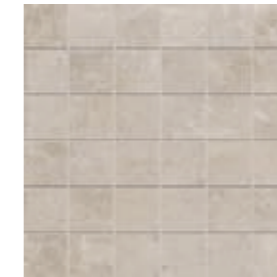

**R7MZ** PietrAntica Mosaico Beige  
30x30



**R7N9** PietrAntica Mosaico Multicolor  
30x30



**R7QY** PietrAntica Muretto Bianco  
15x30



**R7QZ** PietrAntica Muretto Beige  
15x30



**R7RA** PietrAntica Muretto Multicolor  
15x30

## tech info

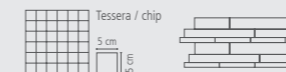

Mosaico assemblato con tratto plastico / Spot-bonded mosaic / Punktverklebtes Mosaik / Mosaïque montée avec trait de colle / Mosaico colocado aplicando cola plástica / Мозаика с сегментами, выполненными из пластмассы - Мозаика, собранная на клеевой точке

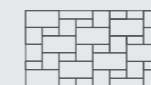

Suggerimento di Posa / Recommended installation pattern / Suggestions de pose / Verlegeempfehlung / Sugerencia de colocación / Рекомендация по укладке

\*

6 diversi soggetti / 6 different motifs / 6 verschiedene Motive / 6 sujets différents / 6 temas diferentes / 6 различных рисунка

\*\*

Battiscopa ottenuto da taglio del fondo / Skirting cut from plain tile / Aus Grundfliese geschnittener Sockel / Plinthe obtenue par découpe du fond / Rodapié obtenido mediante corte del fondo / Плинтус, полученный методом нарезания фоновой плитки

pezzi speciali / trims / spezialteile / pièces spéciales / piezas especiales / специальные изделия



	R7NC	R8FD	R8DU
PietrAntica Bianco			
PietrAntica Beige	R7ND	R8FE	R8DV
PietrAntica Multicolor	R7NE	R8FF	R8DW

\*\*\*

Gradone lineare tagliato ed assemblato / Two-piece straight step / Stufenplatte gerade geschnitten und zusammengesetzt / Large marche droite coupée et assemblée / Escalón lineal cortado y montado / собранная загибающаяся линейная ступень со срезом



Apprezzabili differenze nell'aspetto di superficie e grafica all'interno della stessa produzione. / Clearly distinguishable differences in texture and pattern within the same production run. / Auffällige Unterschiede in Aussehen und Struktur innerhalb der gleichen Produktionscharge. / Différences visibles au niveau de l'aspect et de la fantaisie entre les carreaux du même lot de production. / Diferencias visibles en el aspecto de la superficie y los motivos dentro de un mismo lote de producción. / Заметьные отличия вида поверхности и графики в одной и той же партии.



Variazioni irregolari da piastrella a piastrella. Una piastrella può differire totalmente nell'aspetto superficiale e colore da un'altra. Si consiglia di visionare la gamma cromatica prima della selezione del materiale / Random differences from tile to tile. One tile may have totally different texture and colour from another. The colour range should be viewed before selecting the material. / Wesentliche Variationen von Fliese zu Fliese. Eine Fliese kann sich in Aussehen und Farbe komplett von einer anderen unterscheiden. Es wird empfohlen, das Farbsortiment vor der Auswahl des Materials zu prüfen. / Variations irrégulières entre les carreaux. L'aspect et la couleur peuvent être complètement différents d'un carreau à l'autre. Il est recommandé de consulter la gamme des couleurs avant de sélectionner le matériel. / Variaciones irregulares entre un azulejo y otro. Un azulejo puede ser completamente diferente de otro en el aspecto superficial y el color. Es aconsejable visualizar la gama cromática antes de seleccionar el material. / Неоднородные изменения на разных плитках. Каждая плитка может полностью отличаться по виду поверхности и цвету от другой. Перед отбором материала рекомендуется просмотреть цветовую гамму.

imballi / packaging / verpackungen / emballages / embalajes / упаковки

Scatole / Box / Karton / Boite / Caja / Коробки Pallet / Pallet / Palette / Palette / Pallet / Поддон

	M <sup>2</sup>	KG	M <sup>2</sup>	KG	≠ mm
--	----------------	----	----------------	----	------

fondi / plain tiles / grundfliesen / fonds / fondos / фоновая плитка						
60x120 smooth / rett.	2	1,44	31,47	36	51,84	1132,85
60x60 smooth / rett. / strutt.	3	1,08	22,50	40	43,20	900,00
30x60 smooth / rett. / strutt.	6	1,08	23,04	48	51,84	1105,80

decori / decorative pieces / dekore / décors / decoraciones / двокоры						
30x30 mosaico	4	0,36	8,00	36	21,60	480,00
30x30 decoro cementine	6	0,54	10,00	64	34,56	640,00
15x30 muretto	4	0,18	4,00			

pezzi speciali / trims / spezialteile / pièces spéciales / piezas especiales / специальные изделия						
7x60 BT.B.C.	14	8,40 ml	20,00			9,5
15x60x4 E.ELLE STRUTT.	4	0,36	7,00			
32,5x120 GR.	2	0,78 ml	21,00			

# Realstone\_Slate

75x150 75x75 60x60 30x60



R5YP Realstone\_Slate Ice 75x150

# Realstone\_Slate

75x150 75x75 60x60 30x60



gres fine porcellanato colorato in massa - rettificato monocalibro / colorbody fine porcelain stoneware - rectified monocaliber / durchgefärbtes feinsteinzeug - rektifiziert, in einem werkmaß / grès cérame fin coloré dans la masse - rectifié monocalibre / gres porcelánico fino coloreado en toda la masa - rectificado monocalibre / гомогенный мелкозернистый керамогранит - ректифицированный монокалиберный

superfici / surfaces / finitions / oberflächen / superficies / поверхности:  
naturale/matt + outdoor



H



H



H



H

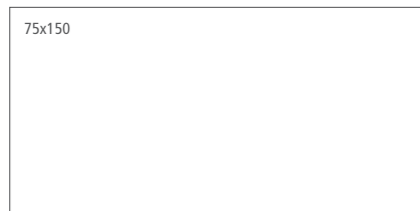

**R5YP** Slate Ice rettificato



**R5YQ** Slate Shell rettificato



**R5YR** Slate Iron rettificato



**R5YS** Slate Musk rettificato

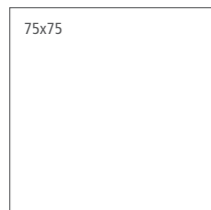

**R5YZ** Slate Ice rettificato  
**R612** Slate Ice strutturato rettificato

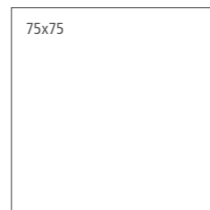

**R5ZA** Slate Shell rettificato  
**R613** Slate Shell strutturato rettificato

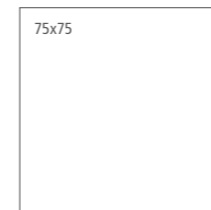

**R5ZC** Slate Iron rettificato  
**R614** Slate Iron strutturato rettificato

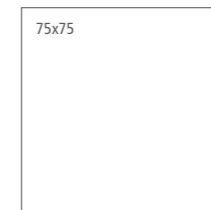

**R5ZD** Slate Musk rettificato  
**R615** Slate Musk strutturato rettificato

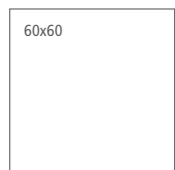

**R5ZF** Slate Ice rettificato

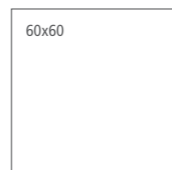

**R5ZG** Slate Shell rettificato



**R5ZH** Slate Iron rettificato



**R5ZJ** Slate Musk rettificato



**R5ZL** Slate Ice rettificato  
**R6YS** Slate Ice strutturato rettificato



**R5ZM** Slate Shell rettificato  
**R6YT** Slate Shell strutturato rettificato



**R5ZN** Slate Iron rettificato  
**R6YU** Slate Iron strutturato rettificato



**R5ZP** Slate Musk rettificato  
**R6YV** Slate Musk strutturato rettificato

stone effect

# Realstone\_Slate

75x150 75x75 60x60 30x60

gres fine porcellanato colorato in massa - rettificato monocalibro / colorbody fine porcelain stoneware - rectified monocaliber / durchgefärbtes feinsteinzeug - rektifiziert, in einem werkmaß / grès cérame fin coloré dans la masse - rectifié monocalibre / gres porcelánico fino coloreado en toda la masa - rectificado monocalibre / гомогенный мелкозернистый керамогранит - ректифицированный монокалиберный

superfici / surfaces / finitions / oberflächen / superficies / поверхности:  
naturale/matt + outdoor

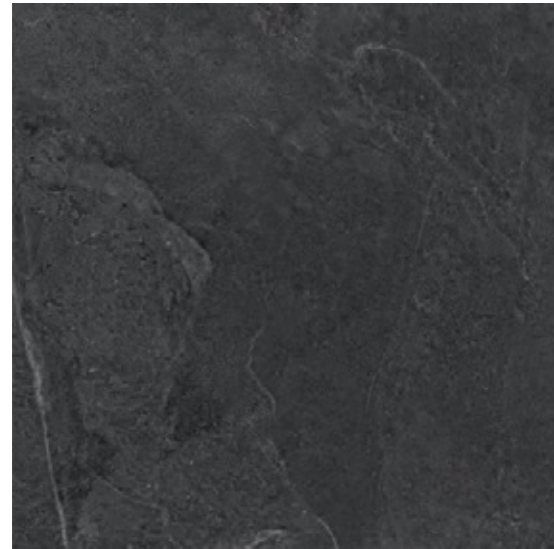

H

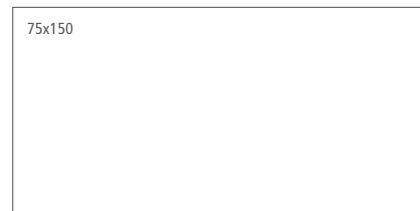

R5YT Slate Black rettificato

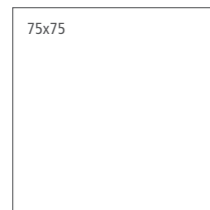

R5ZE Slate Black rettificato  
R618 Slate Black strutturato rettificato

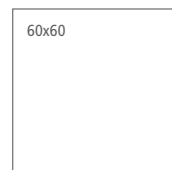

R5ZK Slate Black rettificato



R5ZQ Slate Black rettificato  
R6YW Slate Black strutturato rettificato



R6GQ Slate Mosaico Ice  
30x30



R6GS Slate Mosaico Shell  
30x30

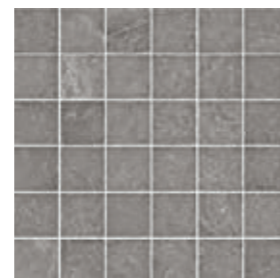

R6GV Slate Mosaico Iron  
30x30

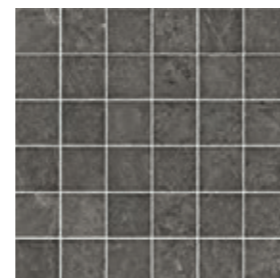

R6GX Slate Mosaico Musk  
30x30



R6GZ Slate Mosaico Black  
30x30



R6GC Slate Mosaico Freccia Ice  
37x41



R6GE Slate Mosaico Freccia Shell  
37x41



R6GG Slate Mosaico Freccia Iron  
37x41



R6GK Slate Mosaico Freccia Musk  
37x41



R6GM Slate Mosaico Freccia Black  
37x41



Apprezzabili differenze nell'aspetto di superficie e grafica all'interno della stessa produzione. / Clearly distinguishable differences in texture and pattern within the same production run. / Auffällige Unterschiede in Aussehen und Struktur innerhalb der gleichen Produktionscharge. / Différences visibles au niveau de l'aspect et de la fantaisie entre les carreaux du même lot de production. / Diferencias visibles en el aspecto de la superficie y los motivos dentro de un mismo lote de producción. / Заметные отличия вида поверхности и графики в одной и той же партии.

## tech info



Mosaico assemblato con tratto plastico / Spot-bonded mosaic / Punktverklebtes Mosaik / Mosaïque montée avec trait de colle / Mosaico colocado aplicando cola plástica / Мозаика с сегментами, выполненными из пластмассы - Мозаика, собранная на клеевой точке



Mosaico assemblato su rete in fibra di vetro / Mosaic mesh - mounted on fibreglass / Auf Glasfasernetz geklebtes Mosaik / Mosaïque montée sur filet en fibre de verre / Mosaico enmallado sobre fibra de vidrio / Мозаика, собранная на сетке из стекловолокна

\*

Battiscopa ottenuto da taglio del fondo / Skirting cut from plain tile / Aus Grundfliese geschnittener Sockel / Plinthe obtenue par découpe du fond / Rodapié obtenido mediante corte del fondo / Плинтус, полученный методом нарезания фоновой плитки

\* \*

Assemblato (pag. 592) / Two-piece L-tile (page 592) / Randstein zweiteilig (S. 592) / Assemblé (page 592) / Montado (pág. 592) / Собранный (стр. 592)

## pezzi speciali / trims / spezialteile / pièces spéciales / piezas especiales / специальные изделия



BT.B.C.\*  
7x60



BT.B.C.\*  
7x75

Slate Ice	R6FP	R6FG
Slate Shell	R6FR	R6FH
Slate Iron	R6FU	R6FJ
Slate Musk	R6FW	R6FK
Slate Black	R6FY	R6FL

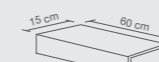

E.ELLE\*\*  
15x60x4

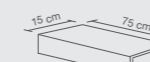

E.ELLE\*\*  
15x75x4

Slate Ice	R6YY	R6XS
Slate Shell	R6YZ	R6XU
Slate Iron	R6ZA	R6XV
Slate Musk	R6ZC	R6XX
Slate Black	R6ZD	R6XY



Vedi Appendice pag. 585  
See Appendix page 585  
Siehe Anhang S. 585  
Voir Annexe page 585  
Véase la pág. 585 del Apéndice  
Смотри приложение на стр. 585

## imballi / packaging / verpackungen / emballages / embalajes / упаковки

Scatole / Box / Karton /  
Boite / Caja / Коробки

Pallet / Pallet / Palette /  
Palette / Pallet / Поддон



fondi / plain tiles / grundfliesen / fonds / fondos / фоновая плитка							
75x150	rettificato	2	2,25	55,99	21	47,25	1175,69
75x75	rettificato	2	1,13	25,48	42	47,25	1070,30
60x60	rettificato	3	1,08	23,38	40	43,20	935,06
30x60	rettificato / strutt.	6	1,08	23,25	48	51,84	1116,04
decori / decorative pieces / dekore / décors / decoraciones / декоры							
37x41	mosaico freccia	4	0,51	15,49	52	26,93	801,79
30x30	mosaico	4	0,36	8,50	80	28,80	660,00
pezzi speciali / trims / spezialteile / pièces spéciales / piezas especiales / специальные изделия							
15x75x4	E.ELLE	2	0,23	10,00			
15x60x4	E.ELLE	4	0,36	7,50			
7x75	BT.B.C.	13	9,75	18,42			10
7x60	BT.B.C.	15	9,0	14,50			10

# Realstone\_Rain

120x120 75x150 75x75 60x60 30x60



R84X Rain Taupe rettificato 75X150  
R5UL Rain Mosaico Taupe 30x30

stone effect

# Realstone\_Rain

120x120 75x150 75x75 60x60 30x60



gres fine porcellanato colorato in massa - rettificato monocalibro / colorbody fine porcelain stoneware - rectified monocaliber / durchgefärbtes feinsteinzeug - rektifiziert, in einem werkmaß / grès cérame fin coloré dans la masse - rectifié monocalibre / gres porcelánico fino coloreado en toda la masa - rectificado monocalibre / гомогенный мелкозернистый керамогранит - ректифицированный монокалиберный

superfici / surfaces / finitions / oberflächen / superficies / поверхности:  
naturale/matt + outdoor



- H** Naturale
- H** Soft
- H** Strutturato

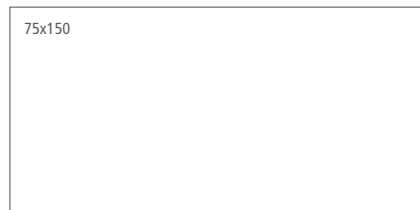

**R84V** Rain Almond rettificato  
**R84Y** Rain Almond Soft rettificato



- H** Naturale
- H** Soft
- H** Strutturato

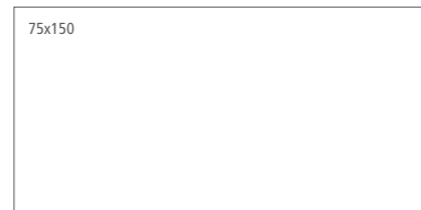

**R84W** Rain Greige rettificato  
**R84Z** Rain Greige Soft rettificato



- H** Naturale
- H** Soft
- H** Strutturato

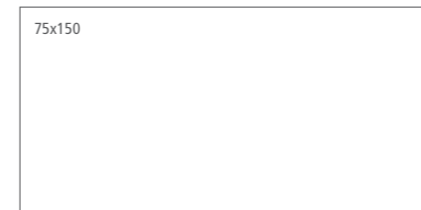

**R84X** Rain Taupe rettificato  
**R852** Rain Taupe Soft rettificato

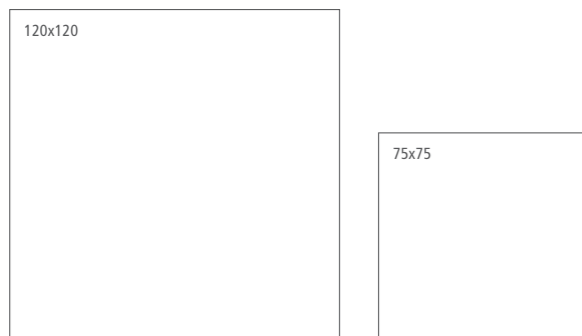

**R1GT** Rain Almond rettificato  
**R86E** Rain Almond rettificato  
**R84S** Rain Almond Soft rettificato



**R1H5** Rain Greige rettificato  
**R86F** Rain Greige rettificato  
**R84T** Rain Greige Soft rettificato

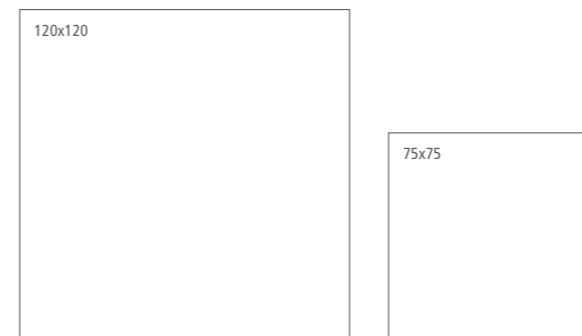

**R1H7** Rain Taupe rettificato  
**R86G** Rain Taupe rettificato  
**R86U** Rain Taupe Soft rettificato

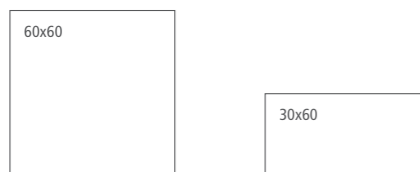

**R857** Rain Almond rettificato  
**R85D** Rain Almond Soft rettificato  
**R85G** Rain Almond rettificato  
**R85K** Rain Almond Soft rettificato  
**R1EE** Rain Almond strutturato rettificato

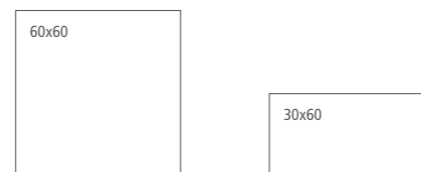

**R85A** Rain Greige rettificato  
**R85E** Rain Greige Soft rettificato  
**R85H** Rain Greige rettificato  
**R85L** Rain Greige Soft rettificato  
**R1FX** Rain Greige strutturato rettificato

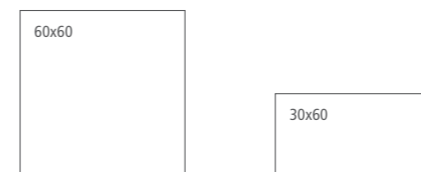

**R85C** Rain Taupe rettificato  
**R85F** Rain Taupe Soft rettificato  
**R85J** Rain Taupe rettificato  
**R85M** Rain Taupe Soft rettificato  
**R1FY** Rain Taupe strutturato rettificato



**RG9T** Rain Almond strutturato Righe rettificato  
60x60



**RG9U** Rain Greige strutturato Righe rettificato  
60x60



**RG9V** Rain Taupe strutturato Righe rettificato  
60x60

stone effect

# Realstone\_Rain

120x120 75x150 75x75 60x60 30x60

gres fine porcellanato colorato in massa - rettificato monocalibro / colorbody fine porcelain stoneware - rectified monocaliber / durchgefärbtes feinsteinzeug - rektifiziert, in einem werkmaß / grès cérame fin coloré dans la masse - rectifié monocalibre / gres porcelánico fino coloreado en toda la masa - rectificado monocalibre / гомогенный мелкозернистый керамогранит - ректифицированный монокалиберный

superfici / surfaces / finitions / oberflächen / superficies / поверхности:  
naturale/matt + outdoor



**R5UJ** Rain Mosaico Almond\*  
30x30

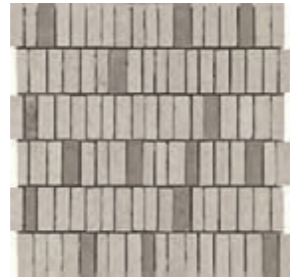

**R5UK** Rain Mosaico Greige\*  
30x30

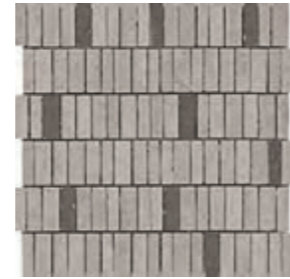

**R5UL** Rain Mosaico Taupe\*  
30x30



**R1FZ** Rain Mosaico Almond  
30x30



**R1GH** Rain Mosaico Greige  
30x30



**R1GJ** Rain Mosaico Taupe  
30x30

Abbinabile ai fondi / Matching with colours / Mit den Grundfliesen kombinierbar / Peut s'associer aux carreaux de base de couleurs / Puede combinarse con los fondos / Сочетается с фоновой плиткой:

Almond, Taupe



**R5TU** Rain Mosaico Rombi Almond  
30x30

Almond, Greige, Taupe



**R5UN** Rain Mosaico Mix\*\*  
30x30

## tech info

\*

Decoro con lustri/metalli preziosi utilizzabile a rivestimento; si consiglia la pulizia da detergenti neutri, non abrasivi. È sconsigliata la posa nell'area doccia. / Decors with lustres/precious metals used for covering; we recommend cleaning with neutral, non-abrasive detergents. Tiles should not be installed in the shower area. / Dekor mit Glanzelementen/Edelmetallen für die Wandverkleidung; es wird die Reinigung mit neutralen, scheuermittelfreien Reinigungsmitteln empfohlen. Die Verlegung in der Duschnische wird nicht empfohlen. / Décor avec lustres/métaux précieux à poser sur le mur. Lavage recommandé avec des détergents neutres, non abrasifs. Pose déconseillée dans la douche. / Decoración con elementos brillantes/metales preciosos utilizable para revestir superficies; se recomienda limpiarla con detergentes neutros, no abrasivos. Se desaconseja colocarla en el área de la ducha. / Декор с блестящим покрытием/драгоценными металлами, используемый для облицовки; рекомендуется чистка с использованием нейтральных, неабразивных моющих средств. Не рекомендуется укладка в душевой зоне.

\*\*

Mix di tutti i fondi / Mixture of all plain tiles / Mischung aller Grundfliesen / Mélange de tous les fonds / Mezcla de todos los fondos / Смесь всех фоновых плиток

\*\*\*

Battiscopa ottenuto da taglio del fondo / Skirting cut from plain tile / Aus Grundfliese geschnittener Sockel / Plinthe obtenue par découpe du fond / Rodapié obtenido mediante corte del fondo / Плинтус, полученный методом нарезания фоновой плитки

\*\*\*\*

Assemblato (pag. 592) / Two-piece L-tile (page 592) / Randstein zweiteilig (S. 592) / Assemblé (page 592) / Montado (pág. 592) / Собираемая (стр. 592)



Apprezabili differenze nell'aspetto di superficie e grafica all'interno della stessa produzione. / Clearly distinguishable differences in texture and pattern within the same production run. / Auffällige Unterschiede in Aussehen und Struktur innerhalb der gleichen Produktionscharge. / Différences visibles au niveau de l'aspect et de la fantaisie entre les carreaux du même lot de production. / Diferencias visibles en el aspecto de la superficie y los motivos dentro de un mismo lote de producción. / Заметные отличия вида поверхности и графики в одной и той же партии.

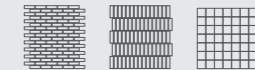

Mosaico assemblato su rete in fibra di vetro  
Mosaic mesh - mounted on fibreglass  
Auf Glasfasernetz geklebtes Mosaik  
Mosaïque montée sur filet en fibre de verre  
Mosaico enmallado sobre fibra de vidrio  
Мозаика, собранная на сетке из стекловолокна



Vedi Appendice pag. 585  
See Appendix page 585  
Siehe Anhang S. 585  
Voir Annexe page 585  
Véase la pág. 585 del Apéndice  
Смотри приложение на стр. 585

pezzi speciali / trims / spezialteile / pièces spéciales / piezas especiales / специальные изделия



BT.B.C.\*\*\*  
7x60



BT.B.C.\*\*\*  
7x75

Rain Almond	R729	R72D
Rain Greige	R72A	R72E
Rain Taupe	R72C	R72F



E.ELLE\*\*\*\*  
15x60x4

Rain Almond	RAZX
Rain Greige	RAZY
Rain Taupe	RAZZ

imballi / packaging / verpackungen / emballages / embalajes / упаковки

Scatole / Box / Karton / Boite / Caja / Коробки

Pallet / Pallet / Palette / Palette / Pallet / Поддон

<b>fondi</b> / plain tiles / grundfliesen / fonds / fondos / фоновая плитка						
120x120 nat.	1	1,44	36,99	36	51,84	1351,36
75x150 nat. / soft	2	2,25	55,99	21	47,25	1175,69
75x75 nat. / soft	2	1,13	23,81	42	47,25	1000,00
60x60 nat.	3	1,08	23,20	40	43,20	928,03
60x60 soft	3	1,08	23,20	40	43,20	928,03
60x60 strutt. Righe	3	1,08	23,20	40	43,20	928,03
30x60 nat. / soft	5	0,90	19,31	48	43,20	926,84
30x60 strutt.	6	1,08	23,00	48	51,84	1103,92

<b>decori</b> / decorative pieces / dekore / décors / decoraciones / декоры						
30x30 mosaico	4	0,36	7,73	80	28,80	618,00
30x30 mos. R1FZ-R1GH-R1GJ	4	0,36	8,00	80	28,80	666,00

<b>pezzi speciali</b> / trims / spezialteile / pièces spéciales / piezas especiales / специальные изделия						
15x60 E.ELLE	4	0,36	8,70			
7x75 BT.B.C.	14	10,50 ml	18,42			9,5
7x60 BT.B.C.	15	9,0 ml	18,18			10

# Realstone\_Cardoso

60x120 75x75 60x60 30x60



RFFP Cardoso Silver rettificato 30X60  
RGFE Cardoso Silver rettificato 60X60  
RGF5 Cardoso Silver rettificato 60X120  
RKT X Cardoso Muretto Silver 30x60  
R56D Woodmania Musk 20x120

stone effect



# Realstone\_Cardoso

60x120 75x75 60x60 30x60



gres fine porcellanato colorato in massa - rettificato monocalibro / colorbody fine porcelain stoneware - rectified monocaliber / durchgefärbtes feinsteinzeug - rektifiziert, in einem werkmaß / grès cérame fin coloré dans la masse - rectifié monocalibre / gres porcelánico fino coloreado en toda la masa - rectificado monocalibre / гомогенный мелкозернистый керамогранит - ректифицированный монокалиберный

superfici / surfaces / finitions / oberflächen / superficies / поверхности:  
naturale/matt + outdoor



- H** Naturale
- H** Soft
- H** Strutturato



**R048** Cardoso Grigio rettificato  
**R049** Cardoso Grigio strutturato rettificato  
**R07P** Cardoso Grigio Soft rettificato

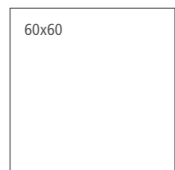

**R04A** Cardoso Grigio rettificato  
**R04C** Cardoso Grigio strutturato rettificato  
**R07Q** Cardoso Grigio Soft rettificato



**R05R** Cardoso Grigio rettificato  
**R05S** Cardoso Grigio strutturato rettificato  
**R07R** Cardoso Grigio Soft rettificato

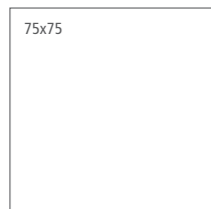

**R04D** Cardoso Grigio rettificato  
**R07N** Cardoso Grigio Soft rettificato



- H** Naturale
- H** Soft
- H** Strutturato



**RGF4** Cardoso Antracite rettificato  
**RGF6** Cardoso Antracite strutturato rettificato  
**RGF8** Cardoso Antracite Soft rettificato

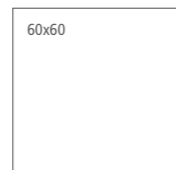

**RGFA** Cardoso Antracite rettificato  
**RFFJ** Cardoso Antracite strutturato rettificato  
**RFFL** Cardoso Antracite Soft rettificato



**RFFN** Cardoso Antracite rettificato  
**RFFQ** Cardoso Antracite strutturato rettificato  
**RFFS** Cardoso Antracite Soft rettificato

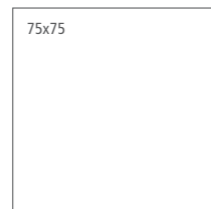

**RGFC** Cardoso Antracite rettificato  
**RFFU** Cardoso Antracite Soft rettificato



- H** Naturale
- H** Soft
- H** Strutturato

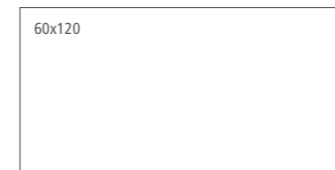

**RGF5** Cardoso Silver rettificato  
**RGF7** Cardoso Silver strutturato rettificato  
**RGF9** Cardoso Silver Soft rettificato



**RGFE** Cardoso Silver rettificato  
**RFFK** Cardoso Silver strutturato rettificato  
**RFFM** Cardoso Silver Soft rettificato



**RFFP** Cardoso Silver rettificato  
**RFFR** Cardoso Silver strutturato rettificato  
**RFFT** Cardoso Silver Soft rettificato

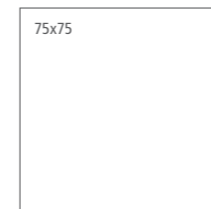

**RGFD** Cardoso Silver rettificato  
**RFFV** Cardoso Silver Soft rettificato

stone effect

# Realstone\_Cardoso

60x120 75x75 60x60 30x60

Gruppo Bla UNI EN 14411\_G

gres fine porcellanato colorato in massa - rettificato monocalibro / colorbody fine porcelain stoneware - rectified monocaliber / durchgefärbtes feinsteinzeug - rektifiziert, in einem werkmaß / grès cérame fin coloré dans la masse - rectifié monocalibre / gres porcelánico fino coloreado en toda la masa - rectificado monocalibre / гомогенный мелкозернистый керамогранит - ректифицированный монокалиберный

superfici / surfaces / finitions / oberflächen / superficies / поверхности:  
naturale/matt + outdoor



**R08V** Cardoso Muretto Grigio  
30x60

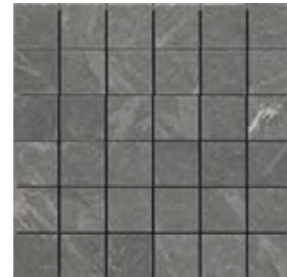

**R08U** Cardoso Mosaico 3D Grigio  
30x30



**RKTW** Cardoso Mosaico Mix\*  
30x30

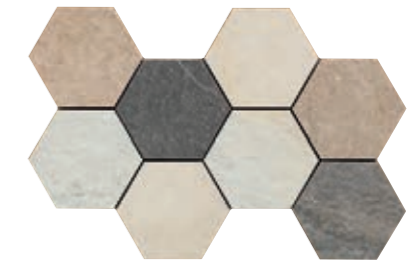

**R12A** Realstone Mosaico Mix\*  
37x24,5

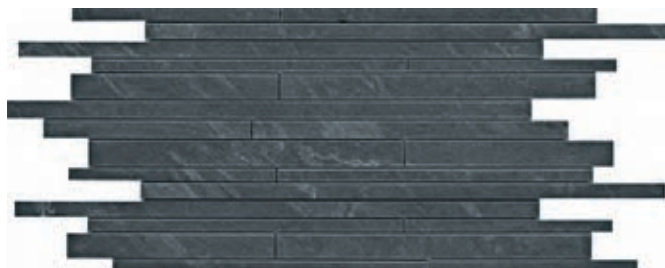

**RKTY** Cardoso Muretto Antracite  
30x60



**RKTX** Cardoso Muretto Silver  
30x60

## tech info

\*

Mix di tutti i fondi / Mixture of all plain tiles / Mischung aller Grundfliesen / Mélange de tous les fonds / Mezcla de todos los fondos / Смесь всех фоновых плиток

\*\*

Battiscopa ottenuto da taglio del fondo / Skirting cut from plain tile / Aus Grundfliese geschnittener Sockel / Plinthe obtenue par découpe du fond / Rodapié obtenido mediante corte del fondo / Плинтус, полученный методом нарезания фоновой плитки

\*\*\*

Assemblato (pag. 592) / Two-piece L-tile (page 592) / Randstein zweiteilig (S. 592) / Assemblé (page 592) / Montado (pág. 592) / Собранный (стр. 592)



Mosaico assemblato su rete in fibra di vetro  
Mosaic mesh - mounted on fibreglass  
Auf Glasfasernetz geklebtes Mosaik  
Mosaïque montée sur filet en fibre de verre  
Mosaico enmallado sobre fibra de vidrio  
Мозаика, собранная на сетке из стекловолокна



Mosaico assemblato con tratto plastico / Spot-bonded mosaic / Punktverklebtes Mosaik / Mosaïque montée avec trait de colle / Mosaico colocado aplicando cola plástica / Мозаика с сегментами, выполненными из пластмассы - Мозаика, собранная на клеевой точке

pezzi speciali / trims / spezialteile / pièces spéciales / piezas especiales / специальные изделия



	R12H	R12G	R02D
Cardoso Grigio			
Cardoso Antracite	RKU2	RKU0	RKU4
Cardoso Silver	RKU1	RKTZ	RKU3



Apprezzabili differenze nell'aspetto di superficie e grafica all'interno della stessa produzione. / Clearly distinguishable differences in texture and pattern within the same production run. / Auffällige Unterschiede in Aussehen und Struktur innerhalb der gleichen Produktionscharge. / Différences visibles au niveau de l'aspect et de la fantaisie entre les carreaux du même lot de production. / Diferencias visibles en el aspecto de la superficie y los motivos dentro de un mismo lote de producción. / Заметные отличия вида поверхности и графики в одной и той же партии.

imballi / packaging / verpackungen / emballages / embalajes / упаковки

Scatole / Box / Karton / Boite / Caja / Коробки  
Pallet / Pallet / Palette / Palette / Pallet / Поддон



fondi / plain tiles / grundfliesen / fonds / fondos / фоновая плитка								
60x120	nat. / soft	2	1,44	31,47	36	51,84	1132,85	9,5
60x120	strutt.	2	1,44	31,47	36	51,84	1132,85	9,5
75x75	nat. / soft	2	1,13	23,81	42	47,25	1000,00	9,5
60x60	nat. / soft.	3	1,08	22,50	40	43,20	900,00	9,5
60x60	strutt.	3	1,08	22,50	40	43,20	900,00	9,5
30x60	nat. / strutt.	5	0,90	19,20	48	43,20	921,60	9,5
30x60	soft	5	0,90	19,20	48	43,20	921,60	9,5

decori / decorative pieces / dekore / décors / decoraciones / декоры								
30x60	muretto	4	0,72	19,37	27	19,44	522,95	9,5
37x24,5	mosaico mix	5	0,34	5,41	54	18,37	292,10	9,5
30x30	mosaico mix	4	0,36	8,00	60	21,60	480,00	9,5
30x30	mosaico 3D	4	0,36	10,44	48	17,28	501,20	9,5

pezzi speciali / trims / spezialteile / pièces spéciales / piezas especiales / специальные изделия						
15x60x4	E.ELLE strutt.	4	0,36	8,70		
7x75	BT.B.C.	14	10,5 ml	18,42		9,5
7x60	BT.B.C.	15	9,0 ml	18,18		9,5

# Realstone\_Jerusalem

60x120 75x75 60x60 30x60



R05A Jerusalem Noce rettificato 75x75  
R05W Jerusalem Noce strutturato rettificato 30x60

stone effect

# Realstone\_Jerusalem

60x120 75x75 60x60 30x60



Gruppo Bla UNI EN 14411\_G

gres fine porcellanato colorato in massa - rettificato monocalibro / colorbody fine porcelain stoneware - rectified monocaliber / durchgefärbtes feinsteinzeug - rektifiziert, in einem werkmaß / grès cérame fin coloré dans la masse - rectifié monocalibre / gres porcelánico fino coloreado en toda la masa - rectificado monocalibre / гомогенный мелкозернистый керамогранит - ректифицированный монокалиберный

superfici / surfaces / finitions / oberflächen / superficies / поверхности:  
naturale/matt + outdoor



- H** Naturale
- H** Soft
- H** Strutturato



**R04V** Jerusalem Avorio rettificato  
**R04X** Jerusalem Avorio strutturato rettificato  
**R08A** Jerusalem Avorio Soft rettificato

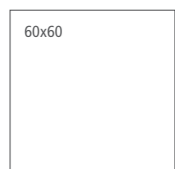

**R04Z** Jerusalem Avorio rettificato  
**R053** Jerusalem Avorio strutturato rettificato  
**R08D** Jerusalem Avorio Soft rettificato



**R05T** Jerusalem Avorio rettificato  
**R05V** Jerusalem Avorio strutturato rettificato  
**R08F** Jerusalem Avorio Soft rettificato

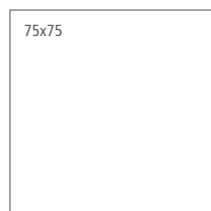

**R057** Jerusalem Avorio rettificato  
**R07Y** Jerusalem Avorio Soft rettificato



- H** Naturale
- H** Soft
- H** Strutturato



**R04W** Jerusalem Noce rettificato  
**R04Y** Jerusalem Noce strutturato rettificato  
**R08C** Jerusalem Noce Soft rettificato



**R052** Jerusalem Noce rettificato  
**R054** Jerusalem Noce strutturato rettificato  
**R08E** Jerusalem Noce Soft rettificato



**R05U** Jerusalem Noce rettificato  
**R05W** Jerusalem Noce strutturato rettificato  
**R08G** Jerusalem Noce Soft rettificato

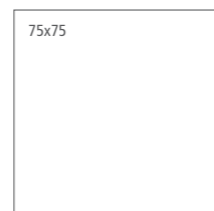

**R05A** Jerusalem Noce rettificato  
**R07Z** Jerusalem Noce Soft rettificato



- H** Naturale
- H** Soft
- H** Strutturato



**R10D** Jerusalem Grigio rettificato  
**R10K** Jerusalem Grigio strutturato rettificato  
**R10H** Jerusalem Grigio Soft rettificato



**R10W** Jerusalem Grigio rettificato  
**R11S** Jerusalem Grigio strutturato rettificato  
**R11W** Jerusalem Grigio Soft rettificato

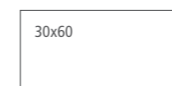

**R11X** Jerusalem Grigio rettificato  
**R11Y** Jerusalem Grigio strutturato rettificato  
**R11Z** Jerusalem Grigio Soft rettificato

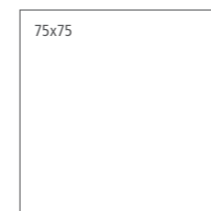

**R09C** Jerusalem Grigio rettificato  
**R09S** Jerusalem Grigio Soft rettificato

stone effect

# Realstone\_Jerusalem

60x120 75x75 60x60 30x60

Gruppo Bla UNI EN 14411\_G

gres fine porcellanato colorato in massa - rettificato monocoloro / colorbody fine porcelain stoneware - rectified monocolor / durchgefärbtes feinsteinzeug - rektifiziert, in einem werkmaß / grès cérame fin coloré dans la masse - rectifié monocolor / gres porcelánico fino coloreado en toda la masa - rectificado monocolor / гомогенный мелкозернистый керамогранит - ректифицированный монокалиберный

superfici / surfaces / finitions / oberflächen / superficies / поверхности:  
naturale/matt + outdoor



R09G Jerusalem Mosaico Avorio  
30x30



R09H Jerusalem Mosaico Noce  
30x30



R122 Jerusalem Mosaico Grigio  
30x30



R09J Jerusalem Mosaico Avorio  
30x30



R09K Jerusalem Mosaico Noce  
30x30



R123 Jerusalem Mosaico Grigio  
30x30



R12A Realstone Mosaico Mix\*  
37x24,5

## tech info

\*

Mix di tutti i fondi / Mixture of all plain tiles / Mischung aller Grundfliesen / Mélange de tous les fonds / Mezcla de todos los fondos / Смесь всех фоновых плиток

\*\*

Battiscopa ottenuto da taglio del fondo / Skirting cut from plain tile / Aus Grundfliese geschnittener Sockel / Plinthe obtenue par découpe du fond / Rodapié obtenido mediante corte del fondo / Плинтус, полученный методом нарезания фоновой плитки

\*\*\*

Assemblato (pag. 592) / Two-piece L-tile (page 592) / Randstein zweiteilig (S. 592) / Assemblé (page 592) / Montado (pág. 592) / Собранный (стр. 592)



Mosaico assemblato su rete in fibra di vetro  
Mosaic mesh - mounted on fiberglass  
Auf Glasfasernetz geklebtes Mosaik  
Mosaïque montée sur filet en fibre de verre  
Mosaico enmallado sobre fibra de vidrio  
Мозаика, собранная на сетке из стекловолокна



Apprezzabili differenze nell'aspetto di superficie e grafica all'interno della stessa produzione. / Clearly distinguishable differences in texture and pattern within the same production run. / Auffällige Unterschiede in Aussehen und Struktur innerhalb der gleichen Produktionscharge. / Différences visibles au niveau de l'aspect et de la fantaisie entre les carreaux du même lot de production. / Diferencias visibles en el aspecto de la superficie y los motivos dentro de un mismo lote de producción. / Заметные отличия вида поверхности и графики в одной и той же партии.

pezzi speciali / trims / spezialteile / pièces spéciales / piezas especiales / специальные изделия



BT.B.C.\*\*  
7x60



BT.B.C.\*\*  
7x75

Jerusalem Avorio	R12L	R12P
Jerusalem Noce	R12M	R12Q
Jerusalem Grigio	R12N	R12R

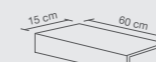

E.ELLE\*\*\*  
15x60x4

Jerusalem Avorio	R06D
Jerusalem Noce	R06E
Jerusalem Grigio	R06F

imballi / packaging / verpackungen / emballages / embalajes / упаковки

Scatole / Box / Karton / Boite / Caja / Коробки

Pallet / Pallet / Palette / Palette / Поддон

	M <sup>2</sup>	KG		M <sup>2</sup>	KG	≠ mm
--	----------------	----	--	----------------	----	---------

fondi / plain tiles / grundfliesen / fonds / fondos / фоновая плитка								
60x120	nat / soft	2	1,44	31,47	36	51,84	1132,85	9,5
60x120	strutt.	2	1,44	31,47	36	51,84	1132,85	9,5
75x75	nat / soft	2	1,13	23,81	42	47,25	1000,00	9,5
60x60		3	1,08	22,50	40	43,20	900,00	9,5
60x60	soft	3	1,08	22,50	40	43,20	900,00	9,5
30x60		5	0,90	19,20	48	43,20	921,60	9,5
30x60	soft	5	0,90	19,20	48	43,20	921,60	9,5

decori / decorative pieces / dekore / décors / decoraciones / декоры								
37x24,5	mosaico mix	5	0,34	5,41	54	18,37	292,10	9,5
30x30	mosaico	4	0,36	7,73	80	28,80	618,00	9,5

pezzi speciali / trims / spezialteile / pièces spéciales / piezas especiales / специальные изделия								
15x60	E.ELLE	4	0,36	8,70				
7x75	BT.B.C.	14	10,50 ml	18,42				9,5
7x60	BT.B.C.	15	9,0 ml	18,18				9,5

Per le pavimentazioni esterne non protette, Ragno consiglia di creare una pendenza  $\geq 1,5\%$  sulla superficie calpestabile allo scopo di limitare il formarsi di ristagni d'acqua localizzati. Nel caso in cui questi ristagni permangano sulla superficie delle piastrelle nonostante una posa a regola d'arte, è necessario intervenire meccanicamente con l'utilizzo di scope o aspira-liquidi. / For unprotected outdoor pavings, Ragno recommends the creation of a gradient of  $\geq 1.5\%$  on the finished surface, to prevent the formation of patches of standing water. In the event that standing water persists on the surface of the tiles in spite of correct installation, it must be removed mechanically with the aid of brooms or wet-and-dry vacuum cleaners. / Zur Unterbindung von punktueller Stauwasserbildung bei Belägen in ungeschützten Außenbereichen, empfiehlt die Ragno die Ausbildung eines Gefälles  $\geq 1,5\%$  auf der Trittlfläche. Sollte trotz fachgerechter Verlegung Stauwasser auf der Fliesenoberfläche zurückbleiben, ist dessen mechanische Entfernung mit Hilfe eines Besens oder Nasssaugers erforderlich. / Pour des sols extérieurs non protégés, Ragno conseille de créer une inclinaison  $\geq 1,5\%$  sur la surface de piétinement en vue de limiter la stagnation localisée de l'eau. Si, malgré une pose dans les règles de l'art, cette stagnation devait persister à la surface des carreaux, une intervention mécanique, au moyen de balais et d'aspirateurs de liquides, est alors nécessaire. / En el caso de pavimentaciones exteriores no protegidas, Ragno recomienda crear una pendiente  $\geq 1,5\%$  en la superficie transitable para limitar la formación de depósitos localizados de agua estancada. En caso de que estos depósitos de agua permanezcan en la superficie del azulejo, aun cuando la colocación se haya realizado correctamente, será necesario intervenir mecánicamente empleando un cepillo o un aspirador de líquidos. / Для наружных незащищенных полов Ragno рекомендует создавать уклон  $\geq 1,5\%$  на пешеходной поверхности для снижения образования локальных застоев воды. В случае, если застои воды образуются на плитке несмотря на правильную укладку, необходимо прибегать к использованию механических средств, таких как щетки или же аппараты для сбора жидкостей.

# Realstone\_Quarzite

60x120 60x60 30x60



R04E Quarzite Grigio rettificato 60x120  
R04L Quarzite Grigio rettificato 60x60  
R07J Quarzite Grigio rettificato 30x60  
R04H Quarzite Grigio strutturato rettificato 60x120  
R04P Quarzite Grigio strutturato rettificato 60x60  
R07L Quarzite Grigio strutturato rettificato 30x60

stone effect

# Realstone\_Quarzite

60x120 60x60 30x60



Gruppo Bla UNI EN 14411\_G

gres fine porcellanato colorato in massa - rettificato monocalibro / colorbody fine porcelain stoneware - rectified monocaliber / durchgefärbtes feinsteinzeug - rektifiziert, in einem werkmaß / grès cérame fin coloré dans la masse - rectifié monocalibre / gres porcelánico fino coloreado en toda la masa - retificado monocalibre / гомогенный мелкозернистый керамогранит - ректифицированный монокалиберный

superfici / surfaces / finitions / oberflächen / superficies / поверхности:  
naturale/matt + outdoor

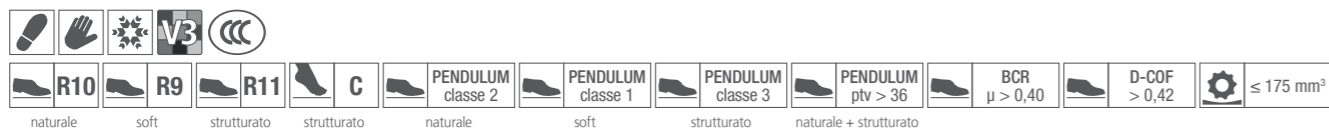

- H** Naturale
- H** Soft
- H** Strutturato

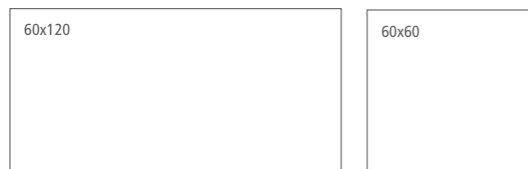

**R04G** Quarzite Bianco rettificato  
**R04K** Quarzite Bianco strutturato rettificato  
**R07T** Quarzite Bianco Soft rettificato

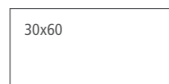

**R07K** Quarzite Bianco rettificato  
**R07M** Quarzite Bianco strutturato rettificato  
**R07X** Quarzite Bianco Soft rettificato

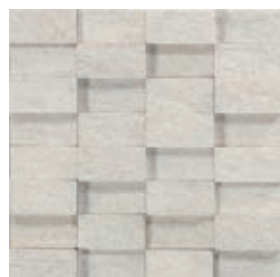

**R08X** Quarzite Mosaico 3D Bianco  
29x29

Per le pavimentazioni esterne non protette, Ragno consiglia di creare una pendenza  $\geq 1,5\%$  sulla superficie calpestabile allo scopo di limitare il formarsi di ristagni d'acqua localizzati. Nel caso in cui questi ristagni permangano sulla superficie delle piastrelle nonostante una posa a regola d'arte, è necessario intervenire meccanicamente con l'utilizzo di scope o aspira-liquidi. / For unprotected outdoor pavings, Ragno recommends the creation of a gradient of  $\geq 1.5\%$  on the finished surface, to prevent the formation of patches of standing water. In the event that standing water persists on the surface of the tiles in spite of correct installation, it must be removed mechanically with the aid of brooms or wet-and-dry vacuum cleaners. / Zur Unterbindung von punktueller Stauwasserbildung bei Belägen in ungeschützten Außenbereichen, empfiehlt die Ragno die Ausbildung eines Gefälles  $\geq 1,5\%$  auf der Trittlfläche. Sollte trotz fachgerechter Verlegung Stauwasser auf der Fliesenoberfläche zurückbleiben, ist dessen mechanische Entfernung mit Hilfe eines Besens oder Nasssaugers erforderlich. / Pour des sols extérieurs non protégés, Ragno conseille de créer une inclinaison  $\geq 1,5\%$  sur la surface de piétinement en vue de limiter la stagnation localisée de l'eau. Si, malgré une pose dans les règles de l'art, cette stagnation devait persister à la surface des carreaux, une intervention mécanique, au moyen de balais et d'aspirateurs de liquides, est alors nécessaire. / En el caso de pavimentaciones exteriores no protegidas, Ragno recomienda crear una pendiente  $\geq 1,5\%$  en la superficie transitable para limitar la formación de depósitos localizados de agua estancada. En caso de que estos depósitos de agua permanezcan en la superficie del azulejo, aun cuando la colocación se haya realizado correctamente, será necesario intervenir mecánicamente empleando un cepillo o un aspirador de líquidos. / Для наружных незащищенных полов Ragno рекомендует создавать уклон  $\geq 1,5\%$  на пешеходной поверхности для снижения образования локальных застоев воды. В случае, если застои воды образуются на плитке несмотря на правильную укладку, необходимо прибегать к использованию механических средств, таких как щетки или же аппараты для сбора жидкостей.



- H** Naturale
- H** Soft
- H** Strutturato



**R04E** Quarzite Grigio rettificato  
**R04H** Quarzite Grigio strutturato rettificato  
**R07S** Quarzite Grigio Soft rettificato

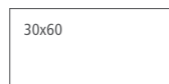

**R07J** Quarzite Grigio rettificato  
**R07L** Quarzite Grigio strutturato rettificato  
**R07W** Quarzite Grigio Soft rettificato



**R08W** Quarzite Mosaico 3D Grigio  
29x29



**R08Z** Quarzite Muretto Bianco  
30x60



**R12A** Realstone Mosaico Mix\*  
37x24,5



**R08Y** Quarzite Muretto Grigio  
30x60

## tech info

\*

Mix di tutti i fondi / Mixture of all plain tiles / Mischung aller Grundfliesen / Mélange de tous les fonds / Mezcla de todos los fondos / Смесь всех фоновых плиток

\*\*

Battiscopa ottenuto da taglio del fondo / Skirting cut from plain tile / Aus Grundfliese geschnittener Sockel / Plinthe obtenue par découpe du fond / Rodapié obtenido mediante corte del fondo / Плинтус, полученный методом нарезания фоновой плитки

\*\*\*

Assemblato (pag. 592) / Two-piece L-tile (page 592) / Randstein zweiteilig (S. 592) / Assemblé (page 592) / Montado (pág. 592) / Собранная (стр. 592)



Mosaico assemblato con tratto plastico / Spot-bonded mosaic / Punktverklebtes Mosaik / Mosaïque montée avec trait de colle / Mosaico colocado aplicando cola plástica / Мозаика с сегментами, выполненными из пластмассы - Мозаика, собранная на клеевой точке



Mosaico assemblato con resina / Resin-bonded mosaic / Harzverklebtes Mosaik / Mosaïque montée avec résine / Mezcla de todos los fondos / Смесь всех фоновых плиток

pezzi speciali / trims / spezialteile / pièces spéciales / piezas especiales / специальные изделия



BT.B.C.\*\*  
7x60

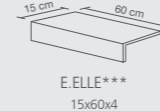

E.ELLE\*\*\*  
15x60x4

Quarzite Bianco	R12K	R06C
Quarzite Grigio	R12J	R03K



Significativa variazione di aspetto superficiale, grafica e colore da piastrella a piastrella e all'interno della stessa piastrella. Si consiglia di visionare la gamma cromatica prima della selezione del materiale. / Significant variation in texture, pattern and colour from tile to tile within the same production run. The colour range should be viewed before selecting the material. / Bedeutende Variation in Aussehen, Struktur und Farbe von Fliese zu Fliese und in ein und derselben Fliese. Es wird empfohlen, das Farbsortiment vor der Auswahl des Materials zu prüfen. / Variation significative au niveau de l'aspect, de la fantaisie et de la couleur entre les carreaux et au sein d'un même carreau. Il est recommandé de consulter la gamme des couleurs avant de sélectionner le matériel. / Variación considerable en el aspecto superficial, los motivos y el color entre un azulejo y otro y dentro del propio azulejo. Es aconsejable visualizar la gama cromática antes de seleccionar el material. / Значительные отличия вида поверхности, графики и цвета в разных плитках и на одной и той же плитке. Перед отбором материала рекомендуется посмотреть цветовую гамму.

imballi / packaging / verpackungen / emballages / embalajes / упаковки

Scatole / Box / Karton / Boite / Caja / Коробки

Pallet / Pallet / Palette / Palette / Поддон



fondi / plain tiles / grundfliesen / fonds / fondos / фоновая плитка

60x120	2	1,44	31,47	36	51,84	1132,85	9,5	
60x120	strutt.	2	1,44	31,47	36	51,84	1132,85	9,5
60x60	3	1,08	22,50	40	43,20	900,00	9,5	
60x60	soft	3	1,08	22,50	40	43,20	900,00	9,5
30x60	5	0,90	19,20	48	43,20	921,60	9,5	

decori / decorative pieces / dekore / décors / decoraciones / декоры

30x60	muretto	4	0,72	19,37	27	19,44	522,96	9,5
37x24,5	mosaico mix	5	0,34	5,41	54	18,37	292,10	9,5
29x29	mosaico	4	0,34	7,83	48	16,15	360,00	9,5

pezzi speciali / trims / spezialteile / pièces spéciales / piezas especiales / специальные изделия

15x60x4	E.ELLE	4	0,36	8,70				
7x60	BT.B.C.	15	9,0 ml	18,18				9,5

# Stoneway\_Ardesia

60x60 30x60 30x30 20x40 20x20



R59F Stoneway\_Ardesia Grigio rettificato 60x60  
R55X Stoneway\_Ardesia Grigio strutturato rettificato 30x60  
R5VY Stoneway\_Ardesia Mosaico Freccia Grigio 30x36

stone effect



# Stoneway\_Ardesia

60x60 30x60 30x30 20x40 20x20



**H** Naturale/Matt  
**H** Strutturato



**H** Naturale/Matt  
**H** Strutturato



**H** Naturale/Matt  
**H** Strutturato



**H** Naturale/Matt  
**H** Strutturato

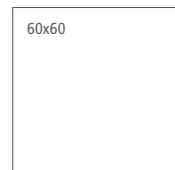

**R5SE** Stoneway\_Ardesia Bianco rettificato  
**R5SN** Stoneway\_Ardesia Bianco strutturato rettificato

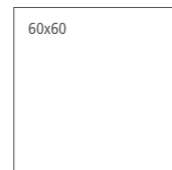

**R5SF** Stoneway\_Ardesia Grigio rettificato  
**R5SP** Stoneway\_Ardesia Grigio strutturato rettificato



**R5SH** Stoneway\_Ardesia Antracite rettificato  
**R5SR** Stoneway\_Ardesia Antracite strutturato rettificato

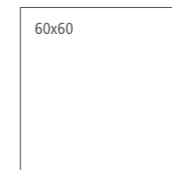

**R5SG** Stoneway\_Ardesia Beige rettificato  
**R5SQ** Stoneway\_Ardesia Beige strutturato rettificato



**R5SJ** Stoneway\_Ardesia Bianco rettificato  
**R5SW** Stoneway\_Ardesia Bianco strutturato rettificato



**R5SK** Stoneway\_Ardesia Grigio rettificato  
**R5SX** Stoneway\_Ardesia Grigio strutturato rettificato



**R5SM** Stoneway\_Ardesia Antracite rettificato  
**R5SZ** Stoneway\_Ardesia Antracite strutturato rettificato

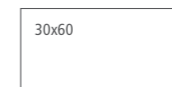

**R5SL** Stoneway\_Ardesia Beige rettificato  
**R5SY** Stoneway\_Ardesia Beige strutturato rettificato



**R5SS** Stoneway\_Ardesia Bianco strutturato rettificato



**R5ST** Stoneway\_Ardesia Grigio strutturato rettificato



**R5SV** Stoneway\_Ardesia Antracite strutturato rettificato



**R5SU** Stoneway\_Ardesia Beige strutturato rettificato



**R5JU** Stoneway\_Ardesia Bianco strutturato



**R5JQ** Stoneway\_Ardesia Bianco strutturato

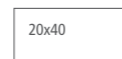

**R5JV** Stoneway\_Ardesia Grigio strutturato



**R5JR** Stoneway\_Ardesia Grigio strutturato



**R5JX** Stoneway\_Ardesia Antracite strutturato



**R5JT** Stoneway\_Ardesia Antracite strutturato



**R5JW** Stoneway\_Ardesia Beige strutturato



**R5JS** Stoneway\_Ardesia Beige strutturato

stone effect

# Stoneway\_Ardesia

60x60 30x60 30x30 20x40 20x20

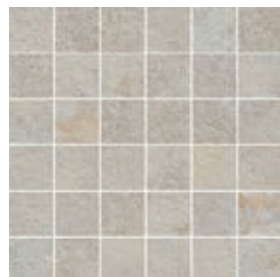

R5VT Stoneway\_Ardesia Mosaico Bianco  
30x30



R5VX Stoneway\_Ardesia Mosaico Freccia Bianco  
30x36



R5VU Stoneway\_Ardesia Mosaico Grigio  
30x30



R5VY Stoneway\_Ardesia Mosaico Freccia Grigio  
30x36

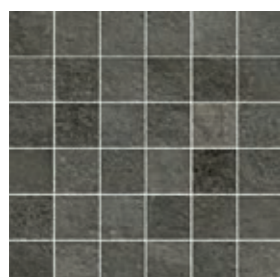

R5VW Stoneway\_Ardesia Mosaico Antracite  
30x30



R5WA Stoneway\_Ardesia Mosaico Freccia Antracite  
30x36

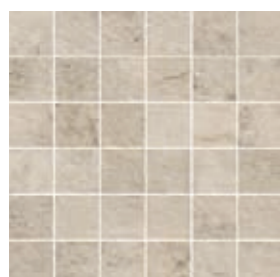

R5VV Stoneway\_Ardesia Mosaico Beige  
30x30



R5VZ Stoneway\_Ardesia Mosaico Freccia Beige  
30x36

## tech info

★

Battiscopa ottenuto da taglio del fondo / Skirting cut from plain tile / Aus Grundfliese geschnittener Sockel / Plinthe obtenue par découpe du fond / Rodapié obtenido mediante corte del fondo / Глинтус, полученный методом нарезания фоновой плитки

★ ★

Assemblato (pag. 592) / Two-piece L-tile (page 592) / Randstein zweiteilig (S. 592) / Assemblé (page 592) / Montado (pág. 592) / Собранный (стр. 592)



Mosaico assemblato con tratto plastico / Spot-bonded mosaic / Punktverklebtes Mosaik / Mosaïque montée avec trait de colle / Mosaico colocado aplicando cola plástica / Мозаика с сегментами, выполненными из пластмассы - Мозаика, собранная на клеевой точке



Significativa variazione di aspetto superficiale, grafica e colore da piastrella a piastrella e all'interno della stessa piastrella. Si consiglia di visionare la gamma cromatica prima della selezione del materiale. / Significant variation in texture, pattern and colour from tile to tile within the same production run. The colour range should be viewed before selecting the material. / Bedeutende Variation in Aussehen, Struktur und Farbe von Fliese zu Fliese und in ein und derselben Fliese. Es wird empfohlen, das Farbsortiment vor der Auswahl des Materials zu prüfen. / Variation significative au niveau de l'aspect, de la fantaisie et de la couleur entre les carreaux et au sein d'un même carreau. Il est recommandé de consulter la gamme des couleurs avant de sélectionner le matériel. / Variación considerable en el aspecto superficial, los motivos y el color entre un azulejo y otro y dentro del propio azulejo. Es aconsejable visualizar la gama cromática antes de seleccionar el material. / Значительные отличия вида поверхности, графики и цвета у разных плиток и на одной и той же плитке. Перед отбором материала рекомендуется просмотреть цветовую гамму.

pezzi speciali / trims / spezialteile / pièces spéciales / piezas especiales / специальные изделия



	R5VA	R5VF	R5VK	R5VP
Stoneway_Ardesia Bianco	R5VA	R5VF	R5VK	R5VP
Stoneway_Ardesia Grigio	R5VC	R5VG	R5VL	R5VQ
Stoneway_Ardesia Antracite	R5VE	R5VJ	R5VN	R5VS
Stoneway_Ardesia Beige	R5VD	R5VH	R5VM	R5VR

imballi / packaging / verpackungen / emballages / embalajes / упаковки

	Scatole / Box / Karton / Boite / Caja / Коробки			Pallet / Pallet / Palette / Palette / Поддон		
	M <sup>2</sup>	KG	#	M <sup>2</sup>	KG	#

fondi / plain tiles / grundfliesen / fonds / fondos / фоновая плитка						
60x60	rettificato	3	1,08	22,50	40	43,20 900,00 9,5
60x60	rettificato strutturato	3	1,08	22,50	40	43,20 900,00 9,5
30x60	rettificato / strutt.	6	1,08	23,04	48	51,84 1105,80 9,5
30x30	rettificato strutturato	12	1,08	11,52	40	43,20 552,90 9,5
20x40		13	1,04	19,35	54	56,16 1045,03 9
20x20		26	1,04	17,74	54	56,16 957,71 9

decori / decorative pieces / dekore / décors / decoraciones / декоры						
30x30	mosaico	4	0,36	7,29	80	28,80 583,67 9,5
30x36	mosaico freccia	4	0,43	11,38	60	25,92 682,99 9,5

pezzi speciali / trims / spezialteile / pièces spéciales / piezas especiales / специальные изделия						
15x60	E.ELLE strutturato	4	0,36	8,00		
20x40	E.ELLE strutturato	6	0,48	12,00		
7x60	BT.B.C.	15	9,00 ml	13,99		9,5
7x60	BT.B.C. strutturato	15	9,00 ml	13,99		9,5

# Stoneway\_Barge Antica

60x60 30x60 20x40 20x20 15x60



R46L Stoneway\_Barge Grigio XT20 60x60  
R3NX Stoneway\_Barge Grigio indoor rettificato 60x60  
R3P4 Stoneway\_Barge Grigio indoor rettificato 30x60  
R3QA Stoneway\_Barge Mosaico Grigio 30x30

stone effect

# Stoneway\_Barge Antica

60x60 30x60 20x40 20x20 15x60



**G** Naturale/Matt  
**H** Strutturato



**R3PE** Stoneway\_Barge Bianco strutt. rettificato  
**R3NY** Stoneway\_Barge Bianco rettificato



**R3PH** Stoneway\_Barge Bianco strutt. rettificato  
**R3PA** Stoneway\_Barge Bianco rettificato



**R4FF** Stoneway\_Barge Bianco rettificato

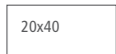

**R45Y** Stoneway\_Barge Bianco strutturato



**R45V** Stoneway\_Barge Bianco strutturato



**R3QC** Stoneway\_Barge Mosaico Bianco  
30x30



**G** Naturale/Matt  
**H** Strutturato

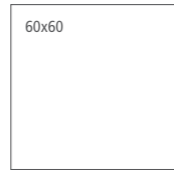

**R3PF** Stoneway\_Barge Beige strutt. rettificato  
**R3NZ** Stoneway\_Barge Beige rettificato



**R3PJ** Stoneway\_Barge Beige strutt. rettificato  
**R3PC** Stoneway\_Barge Beige rettificato



**R4FH** Stoneway\_Barge Beige rettificato



**R45Z** Stoneway\_Barge Beige strutturato



**R45W** Stoneway\_Barge Beige strutturato



**R3QD** Stoneway\_Barge Mosaico Beige  
30x30



**G** Naturale/Matt  
**H** Strutturato



**R3PD** Stoneway\_Barge Grigio strutt. rettificato  
**R3NX** Stoneway\_Barge Grigio rettificato



**R3PG** Stoneway\_Barge Grigio strutt. rettificato  
**R3P4** Stoneway\_Barge Grigio rettificato



**R4FG** Stoneway\_Barge Grigio rettificato



**R465** Stoneway\_Barge Grigio strutturato



**R45X** Stoneway\_Barge Grigio strutturato



**R3QA** Stoneway\_Barge Mosaico Grigio  
30x30

stone effect

# Stoneway\_Barge Antica

60x60 30x60 20x40 20x20 15x60

Gruppo Bla UNI EN 14411\_G

RECTIFIED OUTDOOR 60x60 - 30x60  
RECTIFIED 60x60 - 30x60 - 15x60

gres porcellanato - rettificato monocalibro / porcelain stoneware - rectified monocalibre / feinsteinzeug - rektifiziert, in einem werkmaß / grès cérame émaillé - rectifié monocalibre / gres porcelánico - retificado monocalibre / керамогранит - ректифицированный монокалиберный

OUTDOOR 20x40 - 20x20

gres porcellanato / porcelain stoneware / feinsteinzeug / grès cérame émaillé / gres porcelánico / керамогранит

superfici / surfaces / finitions / oberflächen / superficies / поверхности  
naturale/matt + outdoor



## tech info



Mosaico assemblato su rete in fibra di vetro  
Mosaic mesh - mounted on fibreglass  
Auf Glasfasernetz geklebtes Mosaik  
Mosaïque montée sur filet en fibre de verre  
Mosaico enmallado sobre fibra de vidrio  
Мозаика, собранная на сетке из стекловолоконна

\*

Battiscopa ottenuto da taglio del fondo  
Skirting cut from plain tile  
Aus Grundfliese geschnittener Sockel  
Plinthe obtenue par découpe du fond  
Rodapié obtenido mediante corte del fondo  
Плинтус, полученный методом нарезания фоновой плитки

\*\*

Righe incise con becco civetta smaltato (pag. 592)  
Scored stripes with glazed coved edge (page 592)  
Randstein mit eingefrästen Rillen und glasiertem Halbrundstab (S. 592)  
Bandes gravées avec bord rond émaillé (page 592)  
Rayas grabadas con canto romo esmaltado (pág. 592)  
С нарезными полосками и глазурированным закругленным краем (стр. 592)

\*\*\*

Assemblato (pag. 592) / Two-piece L-tile (page 592) / Randstein zweiteilig (S. 592) / Assemblé (page 592) / Montado (pág. 592) / Собранный (стр. 592)

I formati 60x60 e 30x60 rettificati sono modulari se posati con fuga 2 mm. / The 60x60 and 30x60 rectified sizes can be used in modular combinations if laid with 2 mm joint. / Die rektifizierten Formate 60x60 und 30x60 sind bei Verlegung mit 2-mm-Fuge modular. / Les formats 60x60 et 30x60 rectifiés peuvent se combiner s'ils sont posés avec un joint de 2 mm. / Los formatos de 60 x 60 y de 30 x 60 rectificados son modulares si se colocan dejando juntas de 2 mm. / Обрезные форматы 60x60 и 30x60 могут укладываться модульно со швом 2 мм.



Variazioni irregolari da piastrella a piastrella. Una piastrella può differire totalmente nell'aspetto superficiale e colore da un'altra. Si consiglia di visionare la gamma cromatica prima della selezione del materiale. / Random differences from tile to tile. One tile may have totally different texture and colour from another. The colour range should be viewed before selecting the material. / Wesentliche Variationen von Fliese zu Fliese. Eine Fliese kann sich in Aussehen und Farbe komplett von einer anderen unterscheiden. Es wird empfohlen, das Farbsortiment vor der Auswahl des Materials zu prüfen. / Variations irrégulières entre les carreaux. L'aspect et la couleur peuvent être complètement différents d'un carreau à l'autre. Il est recommandé de consulter la gamme des couleurs avant de sélectionner le matériel. / Variaciones irregulares entre un azulejo y otro. Un azulejo puede ser completamente diferente de otro en el aspecto superficial y el color. Es aconsejable visualizar la gama cromática antes de seleccionar el material. / Неоднородные изменения на разных плитках. Каждая плитка может полностью отличаться по виду поверхности и цвету от другой. Перед отбором материала рекомендуется просмотреть цветовую гамму.

## pezzi speciali / trims / spezialteile / pièces spéciales / piezas especiales / специальные изделия



	R3PV	R46Q	R3PY
Stoneway_Barge Bianco	R3PV	R46Q	R3PY
Stoneway_Barge Beige	R3PW	R46R	R3PZ
Stoneway_Barge Grigio	R3PU	R46S	R3PX



	R3QF	R468
Stoneway_Barge Bianco	R3QF	R468
Stoneway_Barge Beige	R3QG	R46A
Stoneway_Barge Grigio	R3QE	R46C

## imballi / packaging / verpackungen / emballages / embalajes / упаковки

Scatole / Box / Karton / Boite / Caja / Коробки	Pallet / Pallet / Palette / Palette / Pallet / Поддон
M <sup>2</sup>	M <sup>2</sup>
KG	KG
mm	mm

fondi / plain tiles / grundfliesen / fonds / fondos / фоновая плитка							
60x60 strutturato rett.	3	1,08	22,88	40	43,20	915,55	10,5
60x60 rettificato	3	1,08	23,00	40	43,20	956,00	10,5
30x60 strutturato rett.	5	0,90	20,50	48	43,20	984,27	10,5
30x60 rettificato	5	0,90	18,00	48	43,20	895,00	10,5
20x40 strutturato	13	1,04	19,77	54	56,16	1067,88	9
20x20 strutturato	26	1,04	19,07	54	56,16	1029,54	9
15x60 rettificato	8	0,72	15,73	64	46,08	1006,94	10,5

decori / decorative pieces / dekore / décors / decoraciones / декоры							
30x30 mosaico	4	0,36	7,29	80	28,80	583,67	10,5

pezzi speciali / trims / spezialteile / pièces spéciales / piezas especiales / специальные изделия				
30x60 SC.B.C.	5	0,90	22,01	
20x40 E. ELLE	6	0,48	11,35	
15x60 E. ELLE	4	0,36	5,44	
7x60 BT.B.C.	14	8,40 ml	14,73	10,5

Per le pavimentazioni esterne non protette, Ragno consiglia di creare una pendenza  $\geq 1,5\%$  sulla superficie calpestabile allo scopo di limitare il formarsi di ristagni d'acqua localizzati. Nel caso in cui questi ristagni permangano sulla superficie delle piastrelle nonostante una posa a regola d'arte, è necessario intervenire meccanicamente con l'utilizzo di scope o aspira-liquidi. / For unprotected outdoor pavings, Ragno recommends the creation of a gradient of  $\geq 1.5\%$  on the finished surface, to prevent the formation of patches of standing water. In the event that standing water persists on the surface of the tiles in spite of correct installation, it must be removed mechanically with the aid of brooms or wet-and-dry vacuum cleaners. / Zur Unterbindung von punktueller Stauwasserbildung bei Belägen in ungeschützten Außenbereichen, empfiehlt die Ragno die Ausbildung eines Gefälles  $\geq 1,5\%$  auf der Trittlfläche. Sollte trotz fachgerechter Verlegung Stauwasser auf der Fliesenoberfläche zurückbleiben, ist dessen mechanische Entfernung mit Hilfe eines Besens oder Nasssaugers erforderlich. / Pour des sols extérieurs non protégés, Ragno conseille de créer une inclinaison  $\geq 1,5\%$  sur la surface de piétinement en vue de limiter la stagnation localisée de l'eau. Si, malgré une pose dans les règles de l'art, cette stagnation devait persister à la surface des carreaux, une intervention mécanique, au moyen de balais et d'aspirateurs de liquides, est alors nécessaire. / En el caso de pavimentaciones exteriores no protegidas, Ragno recomienda crear una pendiente  $\geq 1,5\%$  en la superficie transitable para limitar la formación de depósitos localizados de agua estancada. En caso de que estos depósitos de agua permanezcan en la superficie del azulejo, aun cuando la colocación se haya realizado correctamente, será necesario intervenir mecánicamente empleando un cepillo o un aspirador de líquidos. / Для наружных незащищенных полов Ragno рекомендует создавать уклон  $\geq 1,5\%$  на пешеходной поверхности для снижения образования локальных застоев воды. В случае, если застои воды образуются на плитке несмотря на правильную укладку, необходимо прибегать к использованию механических средств, таких как щетки или же аппараты для сбора жидкостей.

# Stoneway\_Porfido

30x60 30x30 15x30 15x15



Gruppo Bla UNI EN 14411\_G

30x60 - XT20

gres fine porcellanato colorato in massa / colorbody fine porcelain stoneware / durchgefärbtes feinsteinzeug in einem werkmaß / grès cérame fin coloré dans la masse / gres porcelánico fino coloreado en toda la masa / гомогенный мелкозернистый керамогранит

30x30 - 15x30 - 15x15

gres porcellanato / porcelain stoneware / feinsteinzeug / grès cérame émaillé / gres porcelánico / керамогранит

superfici / surfaces / finitions / oberflächen / superficies / поверхности:  
outdoor



R46Z Stoneway\_Porfido Beige 30x60  
R47G Stoneway\_Porfido Beige 30x30



H



R46Y Stoneway\_Porfido Ivory



R47F Stoneway\_Porfido Ivory



R47T Stoneway\_Porfido Ivory



R47M Stoneway\_Porfido Ivory



H



R47A Stoneway\_Porfido Grey



R47H Stoneway\_Porfido Grey



R47V Stoneway\_Porfido Grey



R47P Stoneway\_Porfido Grey



H

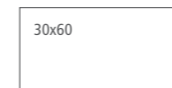

R47D Stoneway\_Porfido Anthracite



R47K Stoneway\_Porfido Anthracite



R47X Stoneway\_Porfido Anthracite



R47R Stoneway\_Porfido Anthracite



H



R47E Stoneway\_Porfido Black

stone effect

# Stoneway\_Porfido

30x60 30x30 15x30 15x15



H

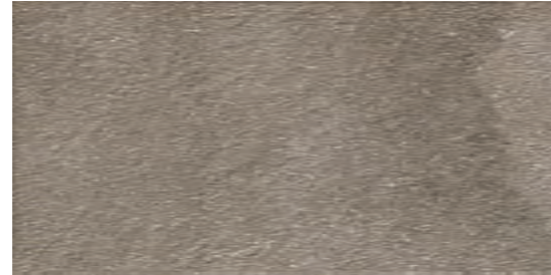

H



R46Z Stoneway\_Porfido Beige



R47G Stoneway\_Porfido Beige



R47C Stoneway\_Porfido Rust



R47J Stoneway\_Porfido Rust



R47U Stoneway\_Porfido Beige



R47N Stoneway\_Porfido Beige



R47W Stoneway\_Porfido Rust



R47Q Stoneway\_Porfido Rust



## tech info

\*

Monolitico (pag. 592) / One-piece L-tile (page 592) / Randstein einteilig (S. 592) / Monolithique (page 592) / Monolítico (pág. 592) / Монолитная (стр. 592)

\*\*

Battiscopa ottenuto da taglio del fondo / Skirting cut from plain tile / Aus Grundfliese geschnittener Sockel / Plinthe obtenue par découpe du fond / Rodapié obtenido mediante corte del fondo / Плинтус, полученный методом нарезания фоновой плитки



Significativa variazione di aspetto superficiale, grafica e colore da piastrella a piastrella e all'interno della stessa piastrella. Si consiglia di visionare la gamma cromatica prima della selezione del materiale. / Significant variation in texture, pattern and colour from tile to tile within the same production run. The colour range should be viewed before selecting the material. / Bedeutende Variation in Aussehen, Struktur und Farbe von Fliese zu Fliese und in ein und derselben Fliese. Es wird empfohlen, das Farbsortiment vor der Auswahl des Materials zu prüfen. / Variation significative au niveau de l'aspect, de la fantaisie et de la couleur entre les carreaux et au sein d'un même carreau. Il est recommandé de consulter la gamme des couleurs avant de sélectionner le matériel. / Variación considerable en el aspecto superficial, los motivos y el color entre un azulejo y otro y dentro del propio azulejo. Es aconsejable visualizar la gama cromática antes de seleccionar el material. / Значительные отличия вида поверхности, графики и цвета у разных плиток и на одной и той же плитке. Перед отбором материала рекомендуется посмотреть цветовую гамму.

## pezzi speciali / trims / spezialteile / pièces spéciales / piezas especiales / специальные изделия



E. ELLE \*  
15x30



BT.B.C. \*\*  
7x60

Stoneway_Porfido Beige	R48H	R48A
Stoneway_Porfido Rust	R48K	R48D
Stoneway_Porfido Anthracite	R48L	R48E
Stoneway_Porfido Ivory	R48G	R47Z
Stoneway_Porfido Grey	R48J	R48C
Stoneway_Porfido Black	R48M	R48F

## imballi / packaging / verpackungen / emballages / embalajes / упаковки

Scatole / Box / Karton / Boite / Caja / Коробки

Pallet / Pallet / Palette / Palette / Pallet / Поддон



fondi / plain tiles / grundfliesen / fonds / fondos / фоновая плитка	Scatole / Box / Karton / Boite / Caja / Коробки		Pallet / Pallet / Palette / Palette / Pallet / Поддон		mm	
	M²	KG	M²	KG		
30x60	5	0,90 18,08	48	43,20 867,63	10	
30x30	12	1,08 22,40	40	43,20 895,98	10	
15x30	16	0,72 13,19	80	57,60 1055,00	9	
15x15	32	0,72 13,19	80	57,60 1055,00	9	
pezzi speciali / trims / spezialteile / pièces spéciales / piezas especiales / специальные изделия	E. ELLE		BT.B.C.			
15x30	6	0,27 3,92	15	9,00 ml 18,23		
7x60					10	

Per le pavimentazioni esterne non protette, Ragno consiglia di creare una pendenza  $\geq 1,5\%$  sulla superficie calpestabile allo scopo di limitare il formarsi di ristagni d'acqua localizzati. Nel caso in cui questi ristagni permangano sulla superficie delle piastrelle nonostante una posa a regola d'arte, è necessario intervenire meccanicamente con l'utilizzo di scope o aspira-liquidi. / For unprotected outdoor pavings, Ragno recommends the creation of a gradient of  $\geq 1.5\%$  on the finished surface, to prevent the formation of patches of standing water. In the event that standing water persists on the surface of the tiles in spite of correct installation, it must be removed mechanically with the aid of brooms or wet-and-dry vacuum cleaners. / Zur Unterbindung von punktueller Stauwasserbildung bei Belägen in ungeschützten Außenbereichen, empfiehlt die Ragno die Ausbildung eines Gefälles  $\geq 1,5\%$  auf der Trittlfläche. Sollte trotz fachgerechter Verlegung Stauwasser auf der Fliesenoberfläche zurückbleiben, ist dessen mechanische Entfernung mit Hilfe eines Besens oder Nasssaugers erforderlich. / Pour des sols extérieurs non protégés, Ragno conseille de créer une inclinaison  $\geq 1,5\%$  sur la surface de piétinement en vue de limiter la stagnation localisée de l'eau. Si, malgré une pose dans les règles de l'art, cette stagnation devait persister à la surface des carreaux, une intervention mécanique, au moyen de balais et d'aspirateurs de liquides, est alors nécessaire. / En el caso de pavimentaciones exteriores no protegidas, Ragno recomienda crear una pendiente  $\geq 1,5\%$  en la superficie transitable para limitar la formación de depósitos localizados de agua estancada. En caso de que estos depósitos de agua permanezcan en la superficie del azulejo, aun cuando la colocación se haya realizado correctamente, será necesario intervenir mecánicamente empleando un cepillo o un aspirador de líquidos. / Для наружных незащищенных полов Ragno рекомендует создавать уклон  $\geq 1,5\%$  на пешеходной поверхности для снижения образования локальных застоев воды. В случае, если застои воды образуются на плитке несмотря на правильную укладку, необходимо прибегать к использованию механических средств, таких как щетки или же аппараты для сбора жидкостей.

# Rock Ground

20x20 20x40



RGAA Rock Ground Roanne Avorio 20X20  
RGAA Rock Ground Roanne Avorio 20X40

stone effect



# Rock Ground

20x20 20x40



H

**RG A7** Rock Ground Roanne Avorio\*  
20x20



H

**RG A A** Rock Ground Roanne Avorio\*  
20x40

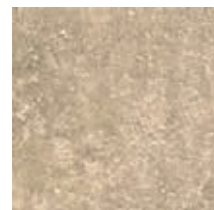

H

**RG A 8** Rock Ground Roanne Beige\*  
20x20

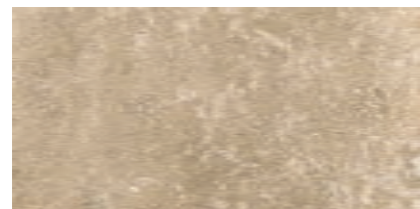

H

**RG A C** Rock Ground Roanne Beige\*  
20x40

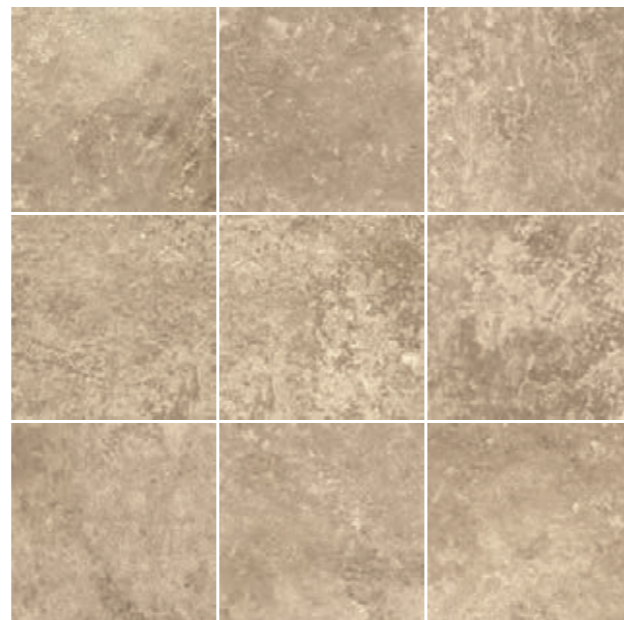

H

**RG A 9** Rock Ground Quarzite Grigio\*  
20x20



H

**RG A D** Rock Ground Quarzite Grigio\*  
20x40

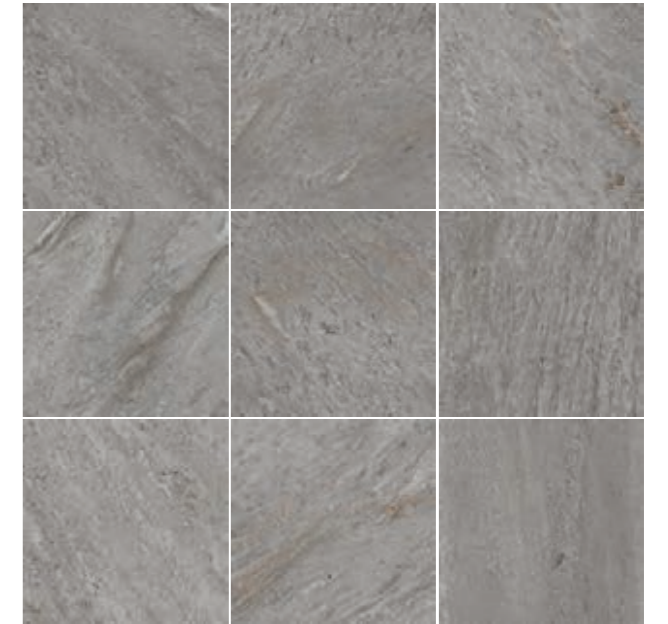

stone effect

## tech info

\*

Bordi irregolari / Uneven edges / Bords irréguliers / Unregelmäßige Kanten / Bordes irregulares / Неровные кромки

\*\*

Assemblato (pag. 592)  
Two-piece L-tile (page 592)  
Randstein zweiteilig (S. 592)  
Assemblé (page 592)  
Montado (pág. 592)  
Собранная (стр. 592)

pezzi speciali / trims / spezialteile / pièces spéciales / piezas especiales / специальные изделия



E.ELLE\*\*  
20x40x4

Rock Ground Roanne Avorio	RGL4
Rock Ground Roanne Beige	RGL5
Rock Ground Quarzite Grigio	RGL6



Significativa variazione di aspetto superficiale, grafica e colore da piastrella a piastrella e all'interno della stessa piastrella. Si consiglia di visionare la gamma cromatica prima della selezione del materiale. / Significant variation in texture, pattern and colour from tile to tile within the same production run. The colour range should be viewed before selecting the material. / Bedeutende Variation in Aussehen, Struktur und Farbe von Fliese zu Fliese und in ein und derselben Fliese. Es wird empfohlen, das Farbsortiment vor der Auswahl des Materials zu prüfen. / Variation significative au niveau de l'aspect, de la fantaisie et de la couleur entre les carreaux et au sein d'un même carreau. Il est recommandé de consulter la gamme des couleurs avant de sélectionner le matériel. / Variación considerable en el aspecto superficial, los motivos y el color entre un azulejo y otro y dentro del propio azulejo. Es aconsejable visualizar la gama cromática antes de seleccionar el material. / Значительные отличия вида поверхности, графики и цвета у разных плиток и на одной и той же плитке. Перед отбором материала рекомендуется посмотреть цветовую гамму.

imballi / packaging / verpackungen / emballages / embalajes / упаковки

Scatole / Box / Karton / Boite / Caja / Коробки

Pallet / Pallet / Palette / Palette / Поддон

	M <sup>2</sup>	KG		M <sup>2</sup>	KG	± mm
--	----------------	----	--	----------------	----	------

fondi / plain tiles / grundfliesen / fonds / fondos / фоновая плитка							
20x20	16	0,64	19,13	54	34,56	1033,22	14
20x40	8	0,64	19,59	54	34,56	1079,95	14

pezzi speciali / trims / spezialteile / pièces spéciales / piezas especiales / специальные изделия						
20x40x4	E.ELLE	4	0,32	11,50		

# Stone

30x60 30x30 10x10



R1UK Stone Whitestone 30x60

gres fine porcellanato colorato in massa / colorbody fine porcelain stoneware / durchgefärbtes Feinsteinzeug / grès cérame fin coloré dans la masse / gres porcelánico fino coloreado en toda la masa / гомогенный мелкозернистый керамогранит

superfici / surfaces / finitions / oberflächen / superficies / поверхности: naturale/matt



**H**



R1UK Whitestone



R1UL Whitestone\*

**F**

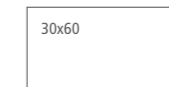

RT08 Blackstone



R1UP Blackstone



R1UM Blackstone\*

## tech info

\*

Punto colla  
Glue-dot



\*\*

Battiscopa ottenuto da taglio del fondo / Skirting cut from plain tile / Aus Grundfliese geschnittener Sockel / Plinthe obtenue par découpe du fond / Rodapié obtenido mediante corte del fondo / Глинтус, полученный методом нарезания фоновой плитки

pezzi speciali / trims / spezialteile / pièces spéciales / piezas especiales / специальные изделия



BT.B.C.\*\*  
9,5x30

Whitestone	R1WU
Blackstone	R2T7

imballi / packaging / verpackungen / emballages / embalajes / упаковки

Scatole / Box / Karton / Boite / Caja / Коробки	Pallet / Pallet / Palette / Palette / Pallet / Поддон
M <sup>2</sup> KG	M <sup>2</sup> KG # mm

fondi / plain tiles / grundfliesen / fonds / fondos / фоновая плитка	30x60		30x30		10x10		
30x60	6	1,08	22,48	48	51,84	1079,21	9,5
30x30	15	1,35	27,00	40	54,00	1080,00	8,5
10x10	84	0,88	14,29	66	57,77	942,96	8

pezzi speciali / trims / spezialteile / pièces spéciales / piezas especiales / специальные изделия	9,5x30		
BT.B.C.	30	9,00 ml 18,00	9,5



## CONCRETE EFFECT

- Gres Effetto Cemento*
- Concrete Effect Stoneware*
- Beton-Cotto-Optik Feinsteinzeug*
- Grès Effet Ciment Cotto*
- Gres Efecto Cotto Cemento*
- Керамогранит С Эффектом*
- Неглазурованной Керамики/Цемент*

# Ironstone

75x150 75x75 60x60 30x60



R7F9 Ironstone Argento rettificato 75x150

concrete effect

# Ironstone

75x150 75x75 60x60 30x60

Gruppo Bia UNI EN 14411\_G

gres fine porcellanato colorato in massa - rettificato monocalibro / colorbody fine porcelain stoneware - rectified monocaliber / durchgefärbtes feinsteinzeug - rektifiziert, in einem werkmaß / grès cérame fin coloré dans la masse - rectifié monocalibre / gres porcelánico fino coloreado en toda la masa - retificado monocalibre / гомогенный мелкозернистый керамогранит - ректифицированный монокалиберный



superfici / surfaces / finitions / oberflächen / superficies / поверхности:  
naturale/matt



G



**R8DZ** Ironstone Bianco rettificato

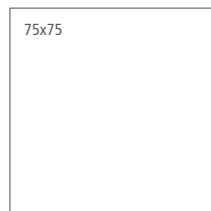

**R8E9** Ironstone Bianco rettificato

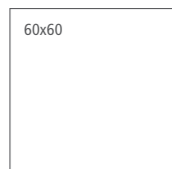

**R8ED** Ironstone Bianco rettificato



**R8EG** Ironstone Bianco rettificato



G



**R7F9** Ironstone Argento rettificato

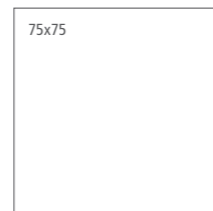

**R7FD** Ironstone Argento rettificato

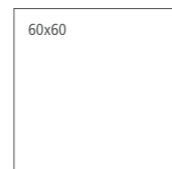

**R7FG** Ironstone Argento rettificato



**R7FK** Ironstone Argento rettificato



G



**R8E3** Ironstone Corten rettificato

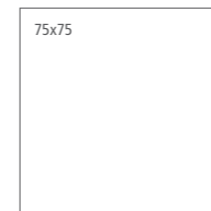

**R8EA** Ironstone Corten rettificato

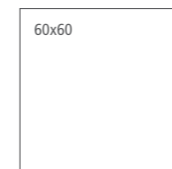

**R8EE** Ironstone Corten rettificato



**R8EH** Ironstone Corten rettificato



G



**R7F8** Ironstone Ghisa rettificato

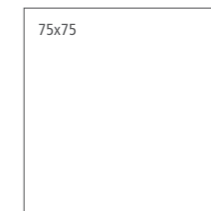

**R7FC** Ironstone Ghisa rettificato

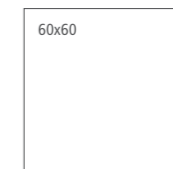

**R7FF** Ironstone Ghisa rettificato



**R7FJ** Ironstone Ghisa rettificato

concrete effect

# Ironstone

75x150 75x75 60x60 30x60

Gruppo Bia UNI EN 14411\_G

gres fine porcellanato colorato in massa - rettificato monocalibro / colorbody fine porcelain stoneware - rectified monocaliber / durchgefärbtes feinsteinzeug - rektifiziert, in einem werkmaß / grès cérame fin coloré dans la masse - rectifié monocalibre / gres porcelánico fino coloreado en toda la masa - rectificado monocalibre / гомогенный мелкозернистый керамогранит - ректифицированный монокалиберный

superfici / surfaces / finitions / oberflächen / superficies / поверхности:  
**naturale/matt**



**R8EU** Ironstone Decoro Retrò Bianco\*  
75x75

**R7XA** Ironstone Decoro Retrò Argento\*  
75x75

**R8EV** Ironstone Decoro Retrò Corten\*  
75x75

**R7XC** Ironstone Decoro Retrò Ghisa\*  
75x75

concrete effect

# Ironstone

75x150 75x75 60x60 30x60

Gruppo Bia UNI EN 14411\_G

gres fine porcellanato colorato in massa - rettificato monocalibro / colorbody fine porcelain stoneware - rectified monocaliber / durchgefärbtes feinsteinzeug - rektifiziert, in einem werkmaß / grès cérame fin coloré dans la masse - rectifié monocalibre / gres porcelánico fino coloreado en toda la masa - rectificado monocalibre / гомогенный мелкозернистый керамогранит - ректифицированный монокалиберный

superfici / surfaces / finitions / oberflächen / superficies / поверхности:  
**naturale/matt**



**R8EX** Ironstone Decoro Tribale Bianco\*\*  
75x75

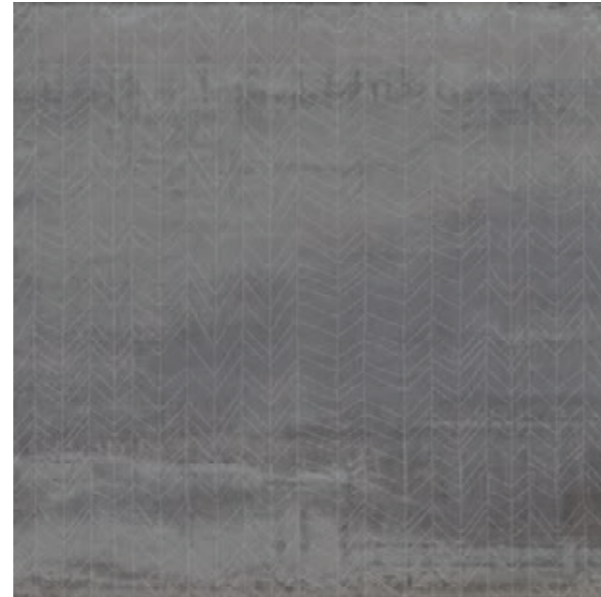

**R7WW** Ironstone Decoro Tribale Argento\*\*  
75x75



**R8EY** Ironstone Decoro Tribale Corten\*\*  
75x75

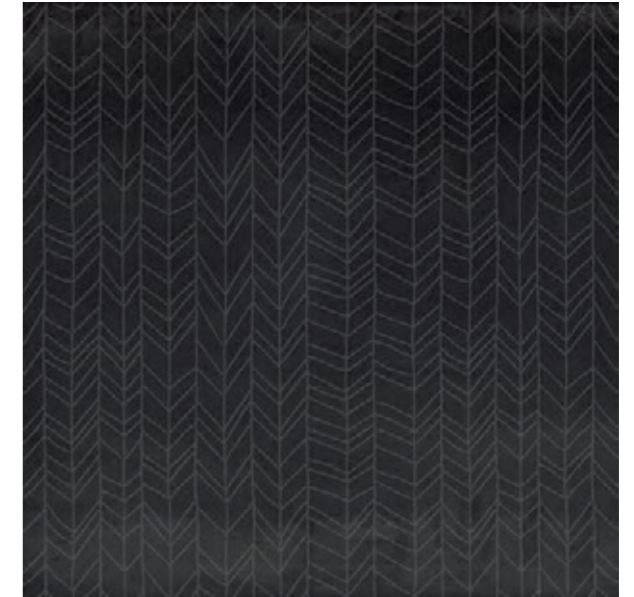

**R7WY** Ironstone Decoro Tribale Ghisa\*\*  
75x75

concrete effect

# Ironstone

75x150 75x75 60x60 30x60

Gruppo Bia UNI EN 14411\_G

gres fine porcellanato colorato in massa - rettificato monocallibro / colorbody fine porcelain stoneware - rectified monocallibro / durchgefärbtes feinsteinzeug - rektifiziert, in einem werkmaß / grès cérame fin coloré dans la masse - rectifié monocallibre / gres porcelánico fino coloreado en toda la masa - rectificado monocallibro / гомогенный мелкозернистый керамогранит - ректифицированный монокалиберный

superfici / surfaces / finitions / oberflächen / superficies / поверхности:  
naturale/matt



A

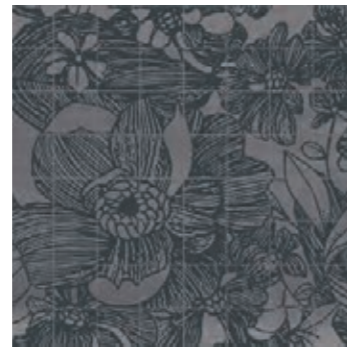

A

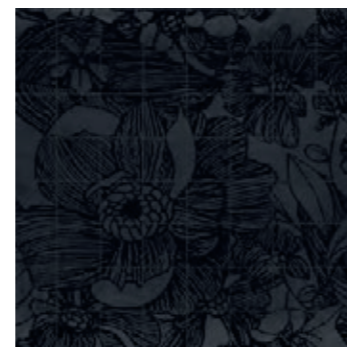

A



B



B

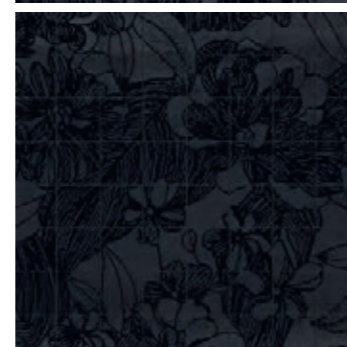

B

**R8FA** Ironstone Mosaico Flora Bianco  
37,5x37,5

**R7RM** Ironstone Mosaico Flora Argento  
37,5x37,5

**R7RL** Ironstone Mosaico Flora Ghisa  
37,5x37,5

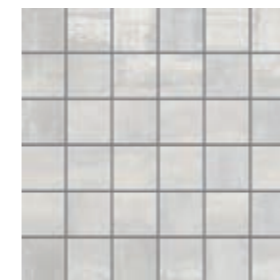

**R8EK** Ironstone Mosaico Bianco  
30x30

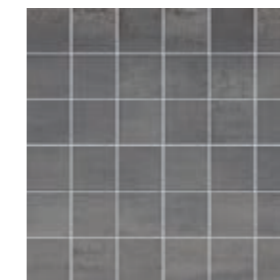

**R7XE** Ironstone Mosaico Argento  
30x30

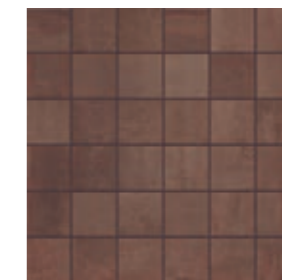

**R8EL** Ironstone Mosaico Corten  
30x30

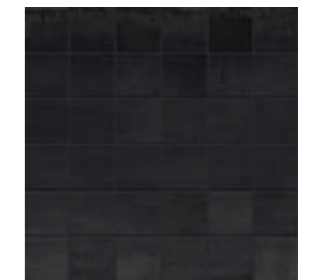

**R7XG** Ironstone Mosaico Ghisa  
30x30

## tech info



Mosaico assemblato con tratto plastico / Spot-bonded mosaic / Punktverklebtes Mosaik / Mosaïque montée avec trait de colle / Mosaico colocado aplicando cola plástica / Мозаика с сегментами, выполненными из глстмассы - Мозаика, собранная на клеевой точке



### Mosaico Flora

Suggerimento di Posa / Recommended installation pattern / Suggestions de pose / Verlegeempfehlung / Sugerencia de colocación / Рекомендация по укладке

### Decorì Retrò e Tribale

Ordine minimo 2 pezzi, produzione su richiesta / Order unit: 2 pieces. Produced to order / Mindestbestellmenge 2 Stücke. Herstellung auf Anfrage. / Commande minimale: 2 pièces. Production sur demande. / Pedido mínimo 2 piezas. Producción bajo pedido. / Минимальный объем заказа составляет 2 штуки, производство – по требованию.



Apprezzabili differenze nell'aspetto di superficie e grafica all'interno della stessa produzione. / Clearly distinguishable differences in texture and pattern within the same production run. / Auffällige Unterschiede in Aussehen und Struktur innerhalb der gleichen Produktionscharge. / Différences visibles au niveau de l'aspect et de la fantaisie entre les carreaux du même lot de production. / Diferencias visibles en el aspecto de la superficie y los motivos dentro de un mismo lote de producción. / Заметные отличия вида поверхности и графики в одной и той же партии.

pezzi speciali / trims / spezialteile / pièces spéciales / piezas especiales / специальные изделия



BT.B.C.\*\*\*  
7x60



BT.B.C.\*\*\*  
7x75

Ironstone Bianco	R8EN	R8ER
Ironstone Argento	R7QA	R7PX
Ironstone Corten	R8EP	R8ES
Ironstone Ghisa	R7QC	R7PY

\*

2 diversi soggetti / 2 different motifs / verschiedene Motive / 2 sujets différents / 2 temas diferentes / 2 различных рисунка

\*\*

Si consiglia di mantenere il senso di posa indicato / Compliance with the specified laying direction is strongly recommended / Es wird empfohlen, die angegebene Verlegerichtung zu beachten / Il est recommandé de conserver le sens de pose indiqué / Se aconseja mantener el sentido de colocación indicado / Рекомендуется сохранить указанное направление укладки

\*\*\*

Battiscopa ottenuto da taglio del fondo / Skirting cut from plain tile / Aus Grundfliese geschnittener Sockel / Plinthe obtenue par découpe du fond / Rodapié obtenido mediante corte del fondo / Плинтус, полученный методом нарезания фоновой плитки

imballi / packaging / verpackungen / emballages / embalajes / упаковки

Scatole / Box / Karton / Boite / Caja / Коробки Pallet / Pallet / Palette / Palette / Palette / Поддон



fondi / plain tiles / grundfliesen / fonds / fondos / фоновая плитка		M <sup>2</sup>		KG		mm		
75x150	rettificato	2	2,25	51,81	21	47,25	1088,00	9,5
75x75	rettificato	2	1,13	23,81	42	47,25	1000,00	9,5
60x60	rettificato	3	1,08	22,50	40	43,20	900,00	9,5
30x60	rettificato	6	1,08	23,04	48	51,84	1105,80	9,5
decorì / decorative pieces / dekore / décors / decoraciones / декоры								
75x75	decoro "su richiesta"	2	1,13	26,00				9,5
37,5x37,5	mosaico Flora	4	0,56	14,00				9,5
30x30	mosaico	4	0,36	8,00				9,5
pezzi speciali / trims / spezialteile / pièces spéciales / piezas especiales / специальные изделия								
7x75	BT.B.C.	14	10,50 ml	18,87				9,5
7x60	BT.B.C.	14	8,40 ml	18,18				9,5



# Re\_Solution

75x150 75x75 60x120 60x60 30x60



R61D Re\_Solution Greige rettificato 75x150

Gruppo Bla UNI EN 14411\_G

gres fine porcellanato colorato in massa - rettificato monocalibro / colorbody fine porcelain stoneware - rectified monocaliber / durchgefärbtes feinsteinzeug - rektifiziert, in einem werkmaß / grès cérame fin coloré dans la masse - rectifié monocalibre / gres porcelánico fino coloreado en toda la masa - rectificado monocalibre / гомогенный мелкозернистый керамогранит - ректифицированный монокалиберный

superfici / surfaces / finitions / oberflächen / superficies / поверхности:  
naturele/matt + glossy + outdoor



**H** Naturale/Matt  
Strutturato

**G** Brill



R619 Re\_Solution Blanc rettificato

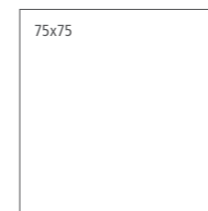

R61H Re\_Solution Blanc rettificato  
R61P Re\_Solution Blanc strutturato rettificato  
R6HL Re\_Solution Blanc Brill rettificato

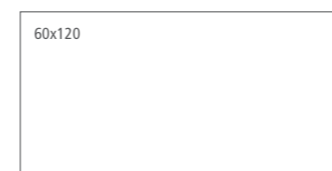

R6YA Re\_Solution Blanc rettificato



R61V Re\_Solution Blanc rettificato  
R6HZ Re\_Solution Blanc Brill rettificato

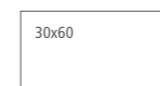

R621 Re\_Solution Blanc rettificato  
R6YK Re\_Solution Blanc Brill rettificato



**H** Naturale/Matt  
Strutturato

**G** Brill



R61C Re\_Solution Linen rettificato

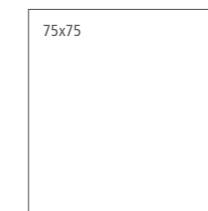

R61J Re\_Solution Linen rettificato  
R61Q Re\_Solution Linen strutturato rettificato  
R6HN Re\_Solution Linen Brill rettificato

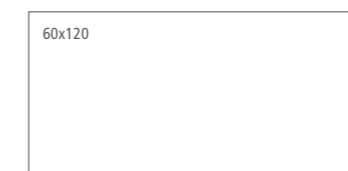

R6YC Re\_Solution Linen rettificato

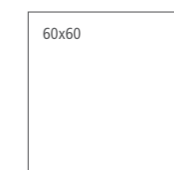

R61W Re\_Solution Linen rettificato  
R6J1 Re\_Solution Linen Brill rettificato



R622 Re\_Solution Linen rettificato  
R6YL Re\_Solution Linen Brill rettificato

concrete effect

# Re\_Solution

75x150 75x75 60x120 60x60 30x60

gres fine porcellanato colorato in massa - rettificato monocalibro / colorbody fine porcelain stoneware - rectified monocaliber / durchgefärbtes feinsteinzeug - rektifiziert, in einem werkmaß / grès cérame fin coloré dans la masse - rectifié monocalibre / gres porcelánico fino coloreado en toda la masa - rectificado monocalibre / гомогенный мелкозернистый керамогранит - ректифицированный монокалиберный

superfici / surfaces / finitions / oberflächen / superficies / поверхности:  
naturale/matt + glossy + outdoor



**H** Naturale/Matt  
Strutturato  
**G** Brill

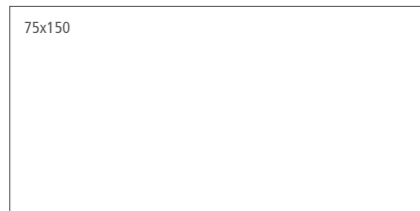

**R61D** Re\_Solution Greige rettificato

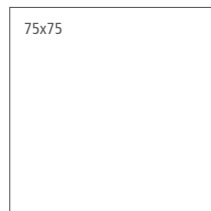

**R61K** Re\_Solution Greige rettificato  
**R61R** Re\_Solution Greige strutturato rettificato  
**R61Q** Re\_Solution Greige Brill rettificato

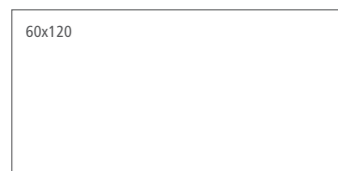

**R61Y** Re\_Solution Greige rettificato

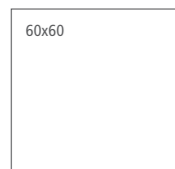

**R61X** Re\_Solution Greige rettificato  
**R61J** Re\_Solution Greige Brill rettificato

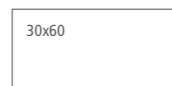

**R623** Re\_Solution Greige rettificato  
**R61M** Re\_Solution Greige Brill rettificato



**H** Naturale/Matt  
Strutturato  
**G** Brill

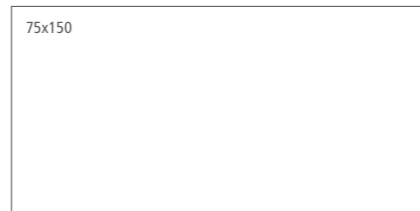

**R61E** Re\_Solution Pencil rettificato

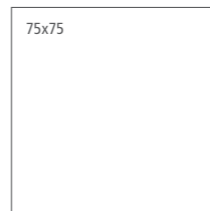

**R61L** Re\_Solution Pencil rettificato  
**R61S** Re\_Solution Pencil strutturato rettificato  
**R61H** Re\_Solution Pencil Brill rettificato

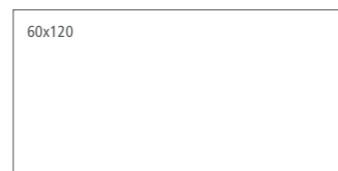

**R61F** Re\_Solution Pencil rettificato

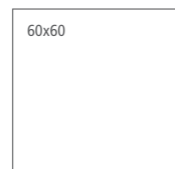

**R61Y** Re\_Solution Pencil rettificato  
**R61S** Re\_Solution Pencil Brill rettificato



**R624** Re\_Solution Pencil rettificato  
**R61N** Re\_Solution Pencil Brill rettificato



**H** Naturale/Matt  
Strutturato  
**G** Brill

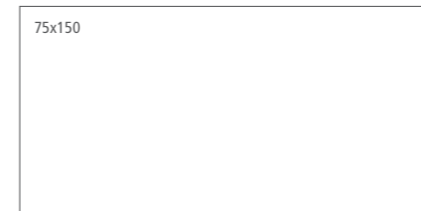

**R61F** Re\_Solution Smoke rettificato

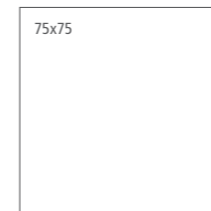

**R61M** Re\_Solution Smoke rettificato  
**R61T** Re\_Solution Smoke strutturato rettificato  
**R61U** Re\_Solution Smoke Brill rettificato

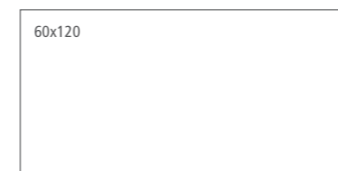

**R61G** Re\_Solution Smoke rettificato



**R61Z** Re\_Solution Smoke rettificato  
**R618** Re\_Solution Smoke Brill rettificato



**R625** Re\_Solution Smoke rettificato  
**R61P** Re\_Solution Smoke Brill rettificato



**H** Naturale/Matt  
Strutturato  
**G** Brill

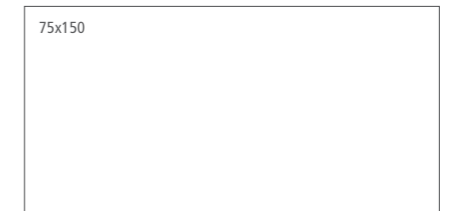

**R61G** Re\_Solution Urban rettificato

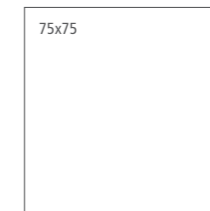

**R61N** Re\_Solution Urban rettificato  
**R61U** Re\_Solution Urban strutturato rettificato  
**R61W** Re\_Solution Urban Brill rettificato



**R61H** Re\_Solution Urban rettificato



**R620** Re\_Solution Urban rettificato  
**R61A** Re\_Solution Urban Brill rettificato



**R626** Re\_Solution Urban rettificato  
**R61Q** Re\_Solution Urban Brill rettificato

# Re\_Solution

75x150 75x75 60x120 60x60 30x60

gres fine porcellanato colorato in massa - rettificato monocalibro / colorbody fine porcelain stoneware - rectified monocaliber / durchgefärbtes feinsteinzeug - rektifiziert, in einem werkmaß / grès cérame fin coloré dans la masse - rectifié monocalibre / gres porcelánico fino coloreado en toda la masa - rectificado monocalibre / гомогенный мелкозернистый керамогранит - ректифицированный монокалиберный

superfici / surfaces / finitions / oberflächen / superficies / поверхности:  
naturale/matt + glossy + outdoor

Abbinabile ai fondi / Matching with colours / Mit den Grundfliesen kombinierbar / Peut s'associer aux carreaux de base de couleurs / Puede combinarse con los fondos / Сочетается с фоновой плиткой:

Blanc



**R6QY** Re\_Solution Decoro Trame Blanc\*  
75x75

Abbinabile ai fondi / Matching with colours / Mit den Grundfliesen kombinierbar / Peut s'associer aux carreaux de base de couleurs / Puede combinarse con los fondos / Сочетается с фоновой плиткой:

Linen, Greige



**R6QX** Re\_Solution Decoro Trame Linen\*  
75x75

Abbinabile ai fondi / Matching with colours / Mit den Grundfliesen kombinierbar / Peut s'associer aux carreaux de base de couleurs / Puede combinarse con los fondos / Сочетается с фоновой плиткой:

Pencil, Smoke

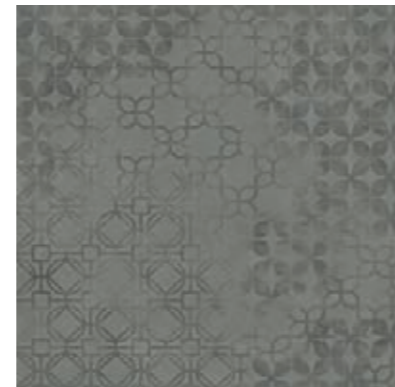

**R6QZ** Re\_Solution Decoro Trame Pencil\*  
75x75

Abbinabile ai fondi / Matching with colours / Mit den Grundfliesen kombinierbar / Peut s'associer aux carreaux de base de couleurs / Puede combinarse con los fondos / Сочетается с фоновой плиткой:

Blanc, Linen, Greige



**R6TK** Re\_Solution Mosaico Blend Linen  
37,5x37,5

Pencil, Smoke, Urban



**R6RA** Re\_Solution Mosaico Blend Pencil  
37,5x37,5



**R6RD** Re\_Solution Mosaico Blanc  
30x30



**R6RE** Re\_Solution Mosaico Linen  
30x30



**R6RF** Re\_Solution Mosaico Greige  
30x30

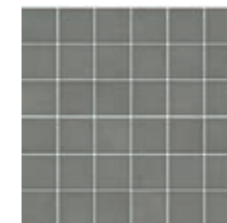

**R6RG** Re\_Solution Mosaico Pencil  
30x30

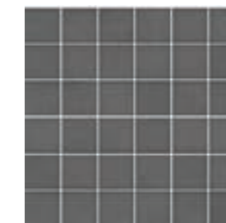

**R6RH** Re\_Solution Mosaico Smoke  
30x30



**R6RJ** Re\_Solution Mosaico Urban  
30x30

## tech info



Mosaico assemblato con tratto plastico / Spot-bonded mosaic / Punktverklebtes Mosaik / Mosaïque montée avec trait de colle / Mosaico colocado aplicando cola plástica / Мозаика с сегментами, выполненными из пластмассы - Мозаика, собранная на клеевой точке

\*\*\*

Battiscopa ottenuto da taglio del fondo / Skirting cut from plain tile / Aus Grundfliese geschnittener Sockel / Plinthe obtenue par découpe du fond / Rodapié obtenido mediante corte del fondo / Плинтус, полученный методом нарезания фоновой плитки

pezzi speciali / trims / spezialteile / pièces spéciales / piezas especiales / специальные изделия



BT.B.C.\*\*  
7x60



BT.B.C.\*\*  
7x75

Re_Solution Blanc	R6TY	R6UQ
Re_Solution Linen	R6UA	R6US
Re_Solution Greige	R6UD	R6UU
Re_Solution Pencil	R6UF	R6UW
Re_Solution Smoke	R6UH	R6UY
Re_Solution Urban	R6UL	R6VC



E.ELLE\*\*\*  
15x75x4

Re_Solution Blanc	R6WX
Re_Solution Linen	R6WZ
Re_Solution Greige	R6XC
Re_Solution Pencil	R6XE
Re_Solution Smoke	R6XG
Re_Solution Urban	R6XJ

\*\*\*

Assemblato (pag. 592) / Two-piece L-tile (page 592) / Randstein zweiteilig (S. 592) / Assemblé (page 592) / Montado (pág. 592) / Собранная (стр. 592)



Apprezzabili differenze nell'aspetto di superficie e grafica all'interno della stessa produzione. / Clearly distinguishable differences in texture and pattern within the same production run. / Auffällige Unterschiede in Aussehen und Struktur innerhalb der gleichen Produktionscharge. / Différences visibles au niveau de l'aspect et de la fantaisie entre les carreaux du même lot de production. / Diferencias visibles en el aspecto de la superficie y los motivos dentro de un mismo lote de producción. / Заметные отличия вида поверхности и графики в одной и той же партии.

imballi / packaging / verpackungen / emballages / embalajes / упаковки

Scatole / Box / Karton / Boite / Caja / Коробки	Pallet / Pallet / Palette / Palette / Pallet / Поддон	# mm
M <sup>2</sup>	KG	

fondi / plain tiles / grundfliesen / fonds / fondos / фоновая плитка						
75x150	rettificato	2	2,25	55,99	21	47,25 1175,69 10,5
60x120	rettificato	2	1,44	32,60	36	51,84 1173,65 10
75x75	rettificato	2	1,13	26,45	42	47,25 1111,02 10
60x60	rettificato	3	1,08	26,22	40	43,20 1048,82 10
30x60	rettificato	6	1,08	24,20	48	51,84 1137,59 10

decori / decorative pieces / dekore / décors / decoraciones / декоры						
75x75	decoro Trame	2	1,13	25,48	42	47,25 1070,30 10
37,5x37,5	mosaico Blend	4	0,56	14,38	60	33,75 863,00 10
30x30	mosaico	4	0,36	8,50	80	28,80 660,00 10

pezzi speciali / trims / spezialteile / pièces spéciales / piezas especiales / специальные изделия					
15x75x4	E.ELLE	2	0,23	10,00	
7x60	BT.B.C.	15	9,00 ml	18,18	10
7x75	BT.B.C.	13	9,75 ml	18,00	10

\* Il decoro Trame non ha un verso di posa. Eventuali irregolarità del disegno dovute alla posa casuale del prodotto non sono da considerarsi un difetto ma una caratteristica distintiva del decoro Trame. / Trame decor can be laid in any direction. Any design irregularities due to the random installation of the product are not to be regarded as defects but rather distinctive features of the Trame decor. / Das Dekor Trame hat keine Verlegerichtung. Unregelmäßigkeiten des Musters, die durch die Verlegung mit Zufallsbild entstehen, sind nicht als Defekt, sondern als besonderes Merkmal des Dekors Trame anzusehen. / Le décor Trame n'a pas de sens de pose. Les éventuelles irrégularités du dessin dues à la pose aléatoire du produit ne doivent pas être considérées comme un défaut mais comme une caractéristique du décor Trame. / La decoración Trame no tiene un sentido de colocación preciso. Cualquier irregularidad en el dibujo que se deba a la colocación aleatoria del producto no deberá considerarse como un defecto sino como una característica distintiva de la decoración Trame. / Декор Trame не имеет направления укладки. Возможная неравномерность рисунка, вызванная произвольной укладкой изделий, должна рассматриваться не как дефект, а как отличительная характеристика декора Trame.

# Patina

120x120 75x150 75x75 60x60 30x60



R85P Patina Crema rettificato 75x150

concrete effect

# Patina

120x120 75x150 75x75 60x60 30x60



gres fine porcellanato colorato in massa - rettificato monocalibro / colorbody fine porcelain stoneware - rectified monocaliber / durchgefärbtes feinsteinzeug - rektifiziert, in einem werkmaß / grès cérame fin coloré dans la masse - rectifié monocalibre / gres porcelánico fino coloreado en toda la masa - rectificado monocalibre / гомогенный мелкозернистый керамогранит - ректифицированный монокалиберный

superfici / surfaces / finitions / oberflächen / superficies / поверхности:  
naturale/matt



H



G



G



G



**R85N** Patina Cera rettificato

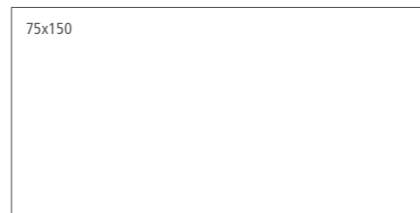

**R85P** Patina Crema rettificato



**R85Q** Patina Cognac rettificato



**R85R** Patina Asfalto rettificato

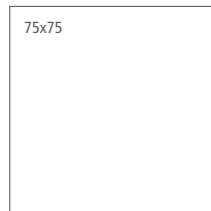

**R85S** Patina Cera rettificato  
**RGK0** Patina Cera Smooth rettificato

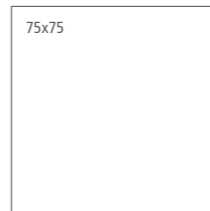

**R85T** Patina Crema rettificato  
**RGK1** Patina Crema Smooth rettificato

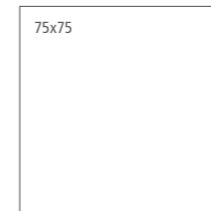

**R85U** Patina Cognac rettificato  
**RGK2** Patina Cognac Smooth rettificato

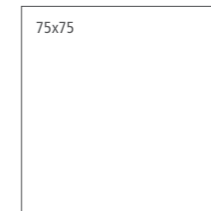

**R85V** Patina Asfalto rettificato  
**RGK3** Patina Asfalto Smooth rettificato

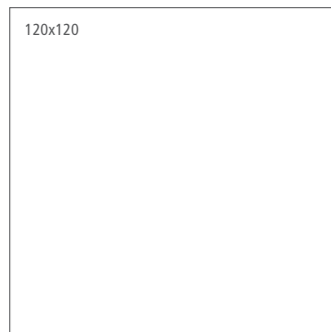

**R1GK** Patina Cera rettificato



**R85Y** Patina Cera rettificato



**R1GP** Patina Crema rettificato



**R85Z** Patina Crema rettificato



**R1GQ** Patina Cognac rettificato



**R861** Patina Cognac rettificato



**R1GR** Patina Asfalto rettificato

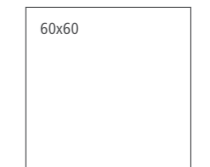

**R86A** Patina Asfalto rettificato



**R86K** Patina Cera rettificato

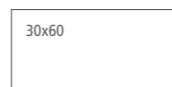

**R86L** Patina Crema rettificato



**R86M** Patina Cognac rettificato



**R86N** Patina Asfalto rettificato

concrete effect

# Patina

120x120 75x150 75x75 60x60 30x60

gres fine porcellanato colorato in massa - rettificato monocalibro / colorbody fine porcelain stoneware - rectified monocaliber / durchgefärbtes feinsteinzeug - rektifiziert, in einem werkmaß / grès cérame fin coloré dans la masse - rectifié monocalibre / gres porcelánico fino coloreado en toda la masa - rectificado monocalibre / гомогенный мелкозернистый керамогранит - ректифицированный монокалиберный

superfici / surfaces / finitions / oberflächen / superficies / поверхности:  
**naturale/matt**



G



F

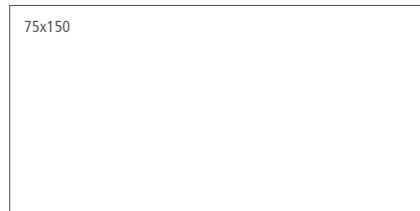

R86H Patina Petrolio rettificato



R86J Patina Marsala rettificato

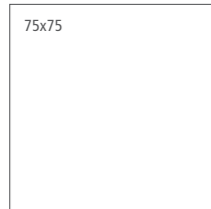

R85W Patina Petrolio rettificato  
RGK4 Patina Petrolio Smooth rettificato

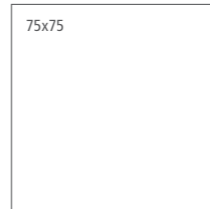

R85X Patina Marsala rettificato  
RGK5 Patina Marsala Smooth rettificato



R1GS Patina Petrolio rettificato

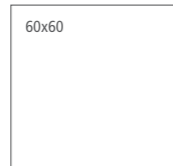

R86C Patina Petrolio rettificato

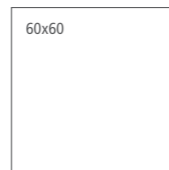

R86D Patina Marsala rettificato



R86Q Patina Marsala rettificato



R86P Patina Petrolio rettificato



R19Q Patina Decoro Cera-Petrolio\*  
75x75



R19R Patina Decoro Crema-Cognac\*  
75x75



R19S Patina Decoro Cognac-Marsala\*  
75x75



concrete effect

# Patina

120x120 75x150 75x75 60x60 30x60

gres fine porcellanato colorato in massa - rettificato monocalibro / colorbody fine porcelain stoneware - rectified monocaliber / durchgefärbtes feinsteinzeug - rektifiziert, in einem werkmaß / grès cérame fin coloré dans la masse - rectifié monocalibre / gres porcelánico fino coloreado en toda la masa - rectificado monocalibre / гомогенный мелкозернистый керамогранит - ректифицированный монокалиберный

superfici / surfaces / finitions / oberflächen / superficies / поверхности:  
naturale/matt



R19U Patina Decoro Petrolio-Marsala\*  
75x75



R19T Patina Decoro Asfalto-Petrolio\*  
75x75



Abbinabile ai fondi / Matching with colours / Mit den Grundfliesen kombinierbar / Peut s'associer aux carreaux de base de couleurs / Puede combinarse con los fondos / Сочетается с фоновой плиткой:

Cera, Crema

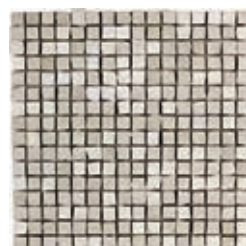

R71C Patina Mosaico Cera  
30x30

Asfalto, Cognac

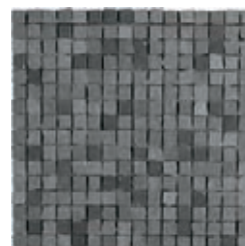

R71D Patina Mosaico Asfalto  
30x30

Petrolio

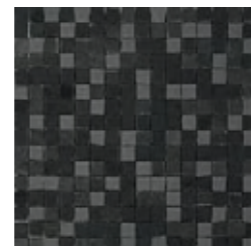

R71E Patina Mosaico Petrolio  
30x30



R19P Patina Mosaico Pop Cognac\*\*  
37,5x37,5

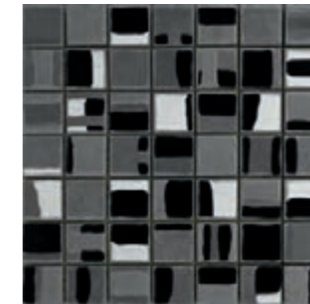

R71G Patina Mosaico Pop Asfalto\*\*  
37,5x37,5

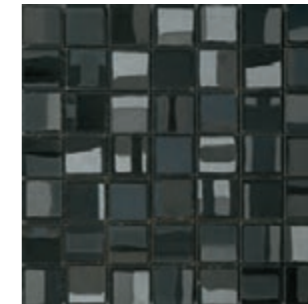

R71H Patina Mosaico Pop Petrolio\*\*  
37,5x37,5

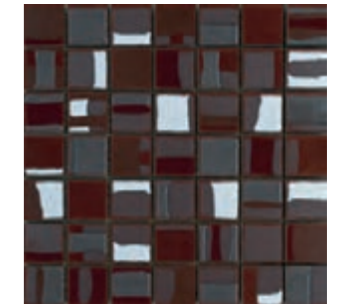

R71J Patina Mosaico Pop Marsala\*\*  
37,5x37,5

## tech info

\*

Decori su richiesta e coordinabili ai fondi rettificati. / Decors are available upon request and can be matched with the rectified plain tiles. / Dekore sind auf Anfrage erhältlich und mit den rektifizierten Grundfliesen kombinierbar. / Les décors sont disponibles sur demande et coordonnables aux fonds rectifiés. / Decorados disponibles bajo pedido y coordinables con las bases rectificadas. / Декоры поставляются по заказу и предназначены для сочетания с обрезной фоновой плиткой.

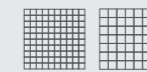

Mosaico assemblato su rete in fibra di vetro / Mosaic mesh - mounted on fibreglass / Auf Glasfasernetz geklebtes Mosaik / Mosaïque montée sur filet en fibre de verre / Mosaico enmallado sobre fibra de vidrio / Мозаика, собранная на сетке из стекловолокна

\*\*

Decoro con lustri/metalli preziosi utilizzabile a rivestimento; si consiglia la pulizia con detergenti neutri, non abrasivi. È sconsigliata la posa nell'area doccia. / Decors with lustres/precious metals used for covering; we recommend cleaning with neutral, non-abrasive detergents. Tiles should not be installed in the shower area. / Dekor mit Glanzelementen/Edelmetallen für die Wandverkleidung; es wird die Reinigung mit neutralen, scheuermittelfreien Reinigungsmitteln empfohlen. Die Verlegung in der Duschnische wird nicht empfohlen. / Décor avec lustres/métaux précieux à poser sur le mur. Lavage recommandé avec des détergents neutres, non abrasifs. Pose déconseillée dans la douche. / Decoración con elementos brillantes/metales preciosos utilizable para revestir superficies; se recomienda limpiarla con detergentes neutros, no abrasivos. Se desaconseja colocarla en el área de la ducha. / Декор с блестящим покрытием/драгоценными металлами, используемый для облицовки; рекомендуется чистка с использованием нейтральных, неабразивных моющих средств. Не рекомендуется укладка в душевой зоне.



Decoro assemblato con tratto plastico / Spot-bonded Decors / Punktverklebtes Dekore / Décors montée avec trait de colle / Decorados colocado aplicando cola plástica / Декоры с сегментами, выполненными из пластмассы - Мозаика, собранная на клеевой точке



Apprezzabili differenze nell'aspetto di superficie e grafica all'interno della stessa produzione. / Clearly distinguishable differences in texture and pattern within the same production run. / Auffällige Unterschiede in Aussehen und Struktur innerhalb der gleichen Produktionscharge. / Différences visibles au niveau de l'aspect et de la fantaisie entre les carreaux du même lot de production. / Diferencias visibles en el aspecto de la superficie y los motivos dentro de un mismo lote de producción. / Заметные отличия вида поверхности и графики в одной и той же партии.

pezzi speciali / trims / spezialteile / pièces spéciales / piezas especiales / специальные изделия



BT.B.C.\*\*\*  
7x75



BT.B.C.\*\*\*  
7x60

Patina Cera	R71P	R71W
Patina Crema	R71R	R71X
Patina Cognac	R71S	R71Y
Patina Asfalto	R71T	R71Z
Patina Petrolio	R71U	R721
Patina Marsala	R71V	R722

imballi / packaging / verpackungen / emballages / embalajes / упаковки

Scatole / Box / Karton / Boite / Caja / Коробки

Pallet / Pallet / Palette / Palette / Поддон



fondi / plain tiles / grundfliesen / fonds / fondos / фоновая плитка							
120x120	1	1,44	37,00	36	51,84	1351,36	10,5
75x150	2	2,25	51,81	21	47,25	1088,00	9,5
75x75	2	1,13	23,81	42	47,25	1000,00	9,5
60x60	3	1,08	22,62	40	43,20	904,71	10
30x60	6	1,08	22,48	48	51,84	1079,10	10
decors / decorative pieces / dekore / décors / decoraciones / декоры							
75x75 decoro	2	1,125	27,00	10	11,250	286,00	9,5
37,5x37,5 mosaico pop	4	0,563	8,00	60	33,751	503,00	9,5
30x30 mosaico	4	0,36	9,60	80	28,80	767,99	10
pezzi speciali / trims / spezialteile / pièces spéciales / piezas especiales / специальные изделия							
7x75 BT.B.C.	14	10,50 ml	18,87				9,5
7x60 BT.B.C.	15	9,00 ml	18,18				10

# Boom

75x150 75x75 60x60 30x60



R00D Boom Acciaio rettificato 75x150  
R00J Boom Acciaio strutturato rettificato 60x60

gres fine porcellanato colorato in massa - rettificato monocalibro / colorbody fine porcelain stoneware - rectified monocaliber / durchgefärbtes feinsteinzeug - rektifiziert, in einem werkmaß / grès cérame fin coloré dans la masse - rectifié monocalibre / gres porcelánico fino coloreado en toda la masa - rectificado monocalibre / гомогенный мелкозернистый керамогранит - ректифицированный монокалиберный

superfici / surfaces / finitions / oberflächen / superficies / поверхности:  
naturale/matt + outdoor



H



R00A Boom Sabbia rettificato

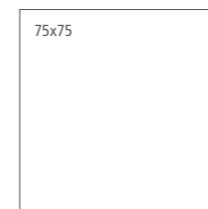

R53J Boom Sabbia rettificato



R54G Boom Sabbia rettificato  
R00G Boom Sabbia strutturato rettificato

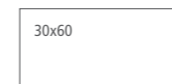

R13S Boom Sabbia rettificato



H



R00C Boom Calce rettificato

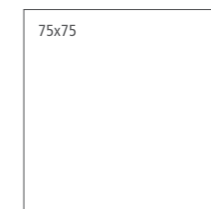

R53K Boom Calce rettificato



R54F Boom Calce rettificato  
R00H Boom Calce strutturato rettificato



R13T Boom Calce rettificato

concrete effect



# Boom

75x150 75x75 60x60 30x60

gres fine porcellanato colorato in massa - rettificato monocalibro / colorbody fine porcelain stoneware - rectified monocaliber / durchgefärbtes feinsteinzeug - rektifiziert, in einem werkmaß / grès cérame fin coloré dans la masse - rectifié monocalibre / gres porcelánico fino coloreado en toda la masa - rectificado monocalibre / гомогенный мелкозернистый керамогранит - ректифицированный монокалиберный

superfici / surfaces / finitions / oberflächen / superficies / поверхности:  
naturale/matt + outdoor

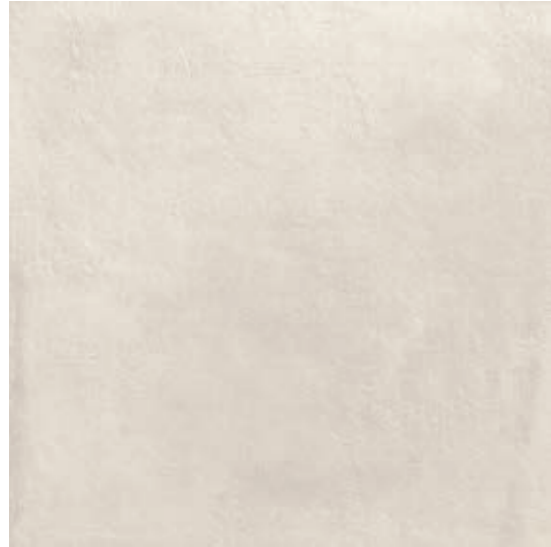

H



**R000** Boom Luce rettificato

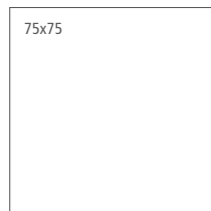

**R53H** Boom Luce rettificato

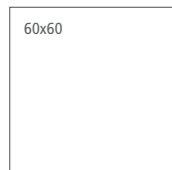

**R54E** Boom Luce rettificato  
**R00F** Boom Luce strutturato rettificato

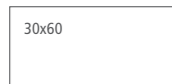

**R13A** Boom Luce rettificato



H

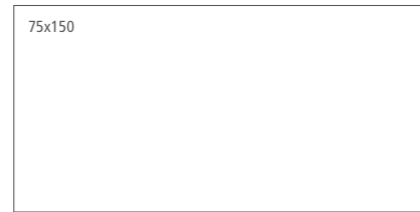

**R00D** Boom Acciaio rettificato

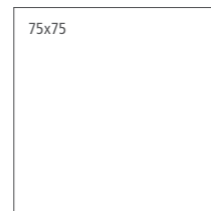

**R53L** Boom Acciaio rettificato

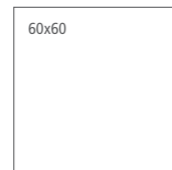

**R54H** Boom Acciaio rettificato  
**R00J** Boom Acciaio strutturato rettificato



**R13C** Boom Acciaio rettificato



H

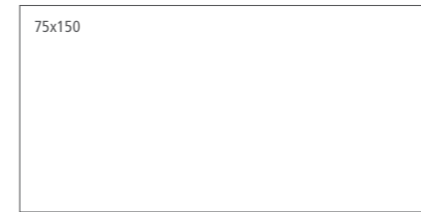

**R00E** Boom Piombo rettificato

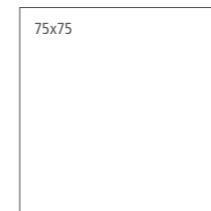

**R53M** Boom Piombo rettificato



**R54J** Boom Piombo rettificato  
**R00K** Boom Piombo strutturato rettificato



**R13D** Boom Piombo rettificato



**R02E** Boom Mosaico Sabbia  
44,9x61,6



**R02F** Boom Mosaico Calce  
44,9x61,6



**R02G** Boom Mosaico Acciaio  
44,9x61,6

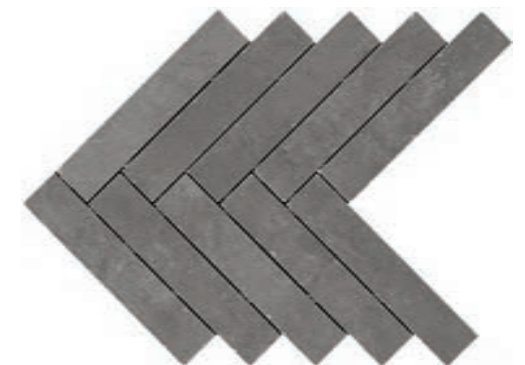

**R02H** Boom Mosaico Piombo  
44,9x61,6

concrete effect

# Boom

75x150 75x75 60x60 30x30

gres fine porcellanato colorato in massa - rettificato monocalibro / colorbody fine porcelain stoneware - rectified monocaliber / durchgefärbtes feinsteinzeug - rektifiziert, in einem werkmaß / grès cérame fin coloré dans la masse - rectifié monocalibre / gres porcelánico fino coloreado en toda la masa - rectificado monocalibre / гомогенный мелкозернистый керамогранит - ректифицированный монокалиберный

superfici / surfaces / finitions / oberflächen / superficies / поверхности:  
naturale/matt + outdoor

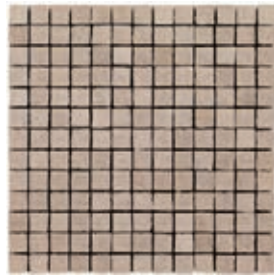

**R54R** Boom Mosaico Sabbia  
30x30

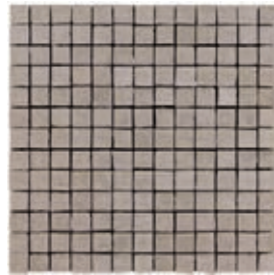

**R54S** Boom Mosaico Calce  
30x30

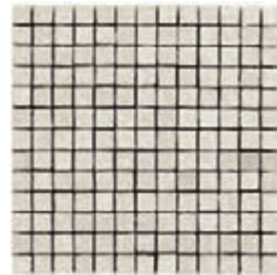

**R54Q** Boom Mosaico Luce  
30x30

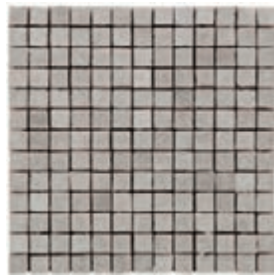

**R54T** Boom Mosaico Acciaio  
30x30

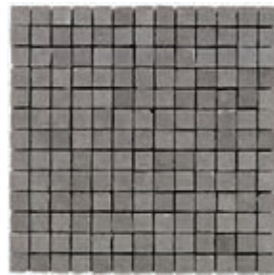

**R54U** Boom Mosaico Piombo  
30x30



**R13X** Boom Mosaico Sabbia  
30x30



**R13Y** Boom Mosaico Calce  
30x30



**R13U** Boom Mosaico Luce  
30x30



**R13V** Boom Mosaico Acciaio  
30x30

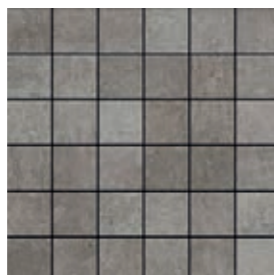

**R13W** Boom Mosaico Piombo  
30x30

## tech info

★

Battiscopa ottenuto da taglio del fondo / Skirting cut from plain tile / Aus Grundfliese geschnittener Sockel / Plinthe obtenue par découpe du fond / Rodapié obtenido mediante corte del fondo / Плинтус, полученный методом нарезания фоновой плитки



Mosaico assemblato su rete in fibra di vetro / Mosaic mesh - mounted on fibreglass / Auf Glasfasernetz geklebtes Mosaik / Mosaïque montée sur filet en fibre de verre / Mosaico enmallado sobre fibra de vidrio / Мозаика, собранная на сетке из стекловолокна



Mosaico assemblato con tratto plastico / Spot-bonded mosaic / Punktverklebtes Mosaik / Mosaïque montée avec trait de colle / Mosaico colocado aplicando cola plástica / Мозаика с сегментами, выполненными из пластмассы - Мозаика, собранная на клеевой точке

pezzi speciali / trims / spezialteile / pièces spéciales / piezas especiales / специальные изделия



BT.B.C.\*  
7x60



BT.B.C.\*  
7x75

	R54L	R53P
Boom Sabbia	R54L	R53P
Boom Calce	R54M	R53Q
Boom Luce	R54K	R53N
Boom Acciaio	R54N	R53R
Boom Piombo	R54P	R53S



Significativa variazione di aspetto superficiale, grafica e colore da piastrella a piastrella e all'interno della stessa piastrella. Si consiglia di visionare la gamma cromatica prima della selezione del materiale. / Significant variation in texture, pattern and colour from tile to tile within the same production run. The colour range should be viewed before selecting the material. / Bedeutende Variation in Aussehen, Struktur und Farbe von Fliese zu Fliese und in ein und derselben Fliese. Es wird empfohlen, das Farbsortiment vor der Auswahl des Materials zu prüfen. / Variation significative au niveau de l'aspect, de la fantaisie et de la couleur entre les carreaux et au sein d'un même carreau. Il est recommandé de consulter la gamme des couleurs avant de sélectionner le matériel. / Variación considerable en el aspecto superficial, los motivos y el color entre un azulejo y otro y dentro del propio azulejo. Es aconsejable visualizar la gama cromática antes de seleccionar el material. / Значительные отличия вида поверхности, графики и цвета у разных плиток и на одной и той же плитке. Перед отбором материала рекомендуется посмотреть цветовую гамму.

imballi / packaging / verpackungen / emballages / embalajes / упаковки

Scatole / Box / Karton / Boite / Caja / Коробки

Pallet / Pallet / Palette / Palette / Pallet / Поддон



<b>fondi</b> / plain tiles / grundfliesen / fonds / fondos / фоновая плитка							
75x150	2	2,25	51,81	21	47,25	1088,00	9,5
75x75	2	1,13	23,81	42	47,25	1000,00	9,5
60x60	3	1,08	26,22	40	43,20	1048,82	9,5
30x60	6	1,08	26,22	48	51,84	1048,82	9,5
<b>decori</b> / decorative pieces / dekore / décors / decoraciones / декоры							
44,9x61,6 mosaico	4	0,68	10,50	20	13,48	210,00	9,5
30x30 mosaico	4	0,36	7,51	80	28,80	600,66	9,5
30x30 mosaico	4	0,36	7,55	80	28,80	603,86	9,5
<b>pezzi speciali</b> / trims / spezialteile / pièces spéciales / piezas especiales / специальные изделия							
7x75 BT.B.C.	14	10,5 ml	18,87				9,5
7x60 BT.B.C.	15	9,00 ml	18,18				9,5

Per le pavimentazioni esterne non protette, Ragno consiglia di creare una pendenza  $\geq 1,5\%$  sulla superficie calpestabile allo scopo di limitare il formarsi di ristagni d'acqua localizzati. Nel caso in cui questi ristagni permangano sulla superficie delle piastrelle nonostante una posa a regola d'arte, è necessario intervenire meccanicamente con l'utilizzo di scope o aspira-liquidi. / For unprotected outdoor pavings, Ragno recommends the creation of a gradient of  $\geq 1.5\%$  on the finished surface, to prevent the formation of patches of standing water. In the event that standing water persists on the surface of the tiles in spite of correct installation, it must be removed mechanically with the aid of brooms or wet-and-dry vacuum cleaners. / Zur Unterbindung von punktueller Stauwasserbildung bei Belägen in ungeschützten Außenbereichen, empfiehlt die Ragno die Ausbildung eines Gefälles  $\geq 1,5\%$  auf der Trittläche. Sollte trotz fachgerechter Verlegung Stauwasser auf der Fliesenoberfläche zurückbleiben, ist dessen mechanische Entfernung mit Hilfe eines Besens oder Nasssaugers erforderlich. / Pour des sols extérieurs non protégés, Ragno conseille de créer une inclinaison  $\geq 1,5\%$  sur la surface de piétinement en vue de limiter la stagnation localisée de l'eau. Si, malgré une pose dans les règles de l'art, cette stagnation devait persister à la surface des carreaux, une intervention mécanique, au moyen de balais et d'aspirateurs de liquides, est alors nécessaire. / En el caso de pavimentaciones exteriores no protegidas, Ragno recomienda crear una pendiente  $\geq 1,5\%$  en la superficie transitable para limitar la formación de depósitos localizados de agua estancada. En caso de que estos depósitos de agua permanezcan en la superficie del azulejo, aun cuando la colocación se haya realizado correctamente, será necesario intervenir mecánicamente empleando un cepillo o un aspirador de líquidos. / Для наружных незащищенных полов Ragno рекомендует создавать уклон  $\geq 1,5\%$  на пешеходной поверхности для снижения образования локальных застоев воды. В случае, если застои воды образуются на плитке несмотря на правильную укладку, необходимо прибегать к использованию механических средств, таких как щетки или же аппараты для сбора жидкостей.

# Rewind

90x90 60x120 75x75 60x60 30x60 45x45 21x18,2 7x28



R4AW Rewind Argilla 75x75  
R4DV Rewind Decoro cementine 21x18,2

concrete effect

# Rewind

90x90 60x120 75x75 60x60 30x60 45x45 21x18,2 7x28

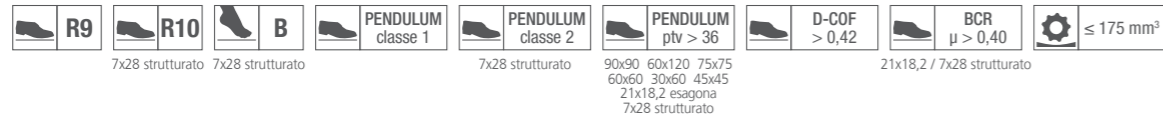

H

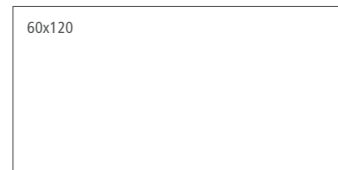

R4DX Rewind Vanilla rettificato

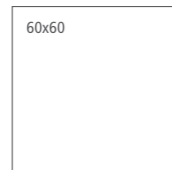

R4AY Rewind Vanilla rettificato

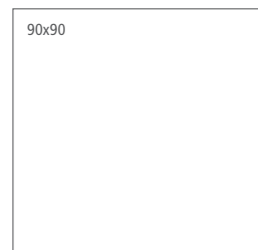

R4KL Rewind Vanilla rettificato



R4CF Rewind Vanilla rettificato

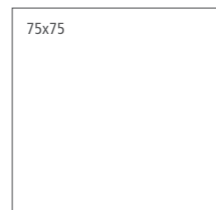

R4AS Rewind Vanilla rettificato

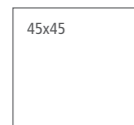

R4JX Rewind Vanilla



R4KY Rewind Vanilla 7x28

H



H

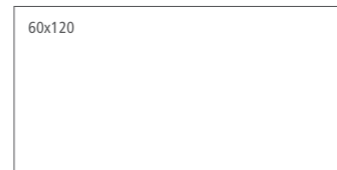

R4DY Rewind Polvere rettificato

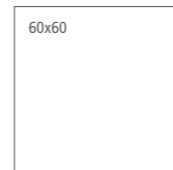

R4AZ Rewind Polvere rettificato

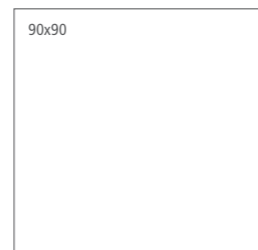

R4KM Rewind Polvere rettificato

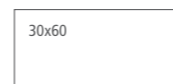

R4CG Rewind Polvere rettificato

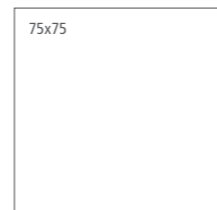

R4AT Rewind Polvere rettificato

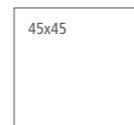

R4JY Rewind Polvere



R4KZ Rewind Polvere 7x28

G



R4PL Rewind Polvere strutturato 7x28

H



H

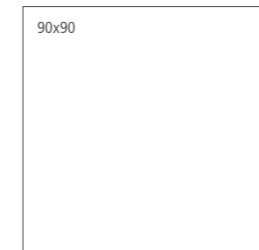

R4KN Rewind Peltro rettificato



R4CA Rewind Peltro rettificato



R4CH Rewind Peltro rettificato

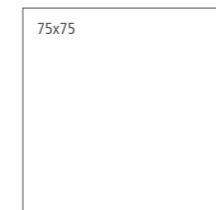

R4AU Rewind Peltro rettificato

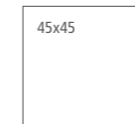

R4JZ Rewind Peltro



R4LA Rewind Peltro 7x28

G



R4PN Rewind Peltro strutturato 7x28

H

gres fine porcellanato colorato in massa - rettificato monocalibro / colorbody fine porcelain stoneware - rectified monocalibre / durchgefärbtes Feinsteinzeug - rektifiziert, in einem werkmaß / grès cérame fin coloré dans la masse - rectifié monocalibre / gres porcelánico fino coloreado en toda la masa - rectificado monocalibre / гомогенный мелкозернистый керамогранит - ректифицированный монокалиберный

45x45

gres fine porcellanato colorato in massa / colorbody fine porcelain stoneware / durchgefärbtes Feinsteinzeug / grès cérame fin coloré dans la masse / gres porcelánico fino coloreado en toda la masa / гомогенный мелкозернистый керамогранит

21x18,2 - 7x28

gres porcellanato / porcelain stoneware / feinsteinzeug / grès cérame émaillé / gres porcelánico / керамогранит

superfici / surfaces / finitions / oberflächen / superficies / поверхности: naturale/matt + outdoor



R4CM Rewind Vanilla 21x18,2

H



R4CN Rewind Polvere 21x18,2

H



R4CP Rewind Peltro 21x18,2

H

concrete effect

# Rewind

90x90 60x120 75x75 60x60 30x60 45x45 21x18,2 7x28

**gres fine porcellanato colorato in massa - rettificato monocalibro** / colorbody fine porcelain stoneware - rectified monocaliber / durchgefärbtes feinsteinzeug - rektifiziert, in einem werkmaß / grès cérame fin coloré dans la masse - rectifié monocalibre / gres porcelánico fino coloreado en toda la masa - rectificado monocalibre / гомогенный мелкозернистый керамогранит - ректифицированный монокалиберный

**gres fine porcellanato colorato in massa** / colorbody fine porcelain stoneware / durchgefärbtes feinsteinzeug / grès cérame fin coloré dans la masse / gres porcelánico fino coloreado en toda la masa / гомогенный мелкозернистый керамогранит

**gres porcellanato** / porcelain stoneware / feinsteinzeug / grès cérame émaillé / gres porcelánico / керамогранит

**superfici** / surfaces / finitions / oberflächen / superficies / поверхности:  
**naturale/matt + outdoor**



H

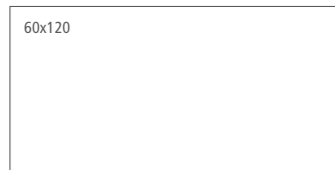

**R4EA** Rewind Corda rettificato

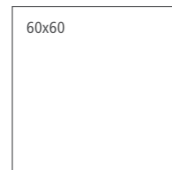

**R4CE** Rewind Corda rettificato

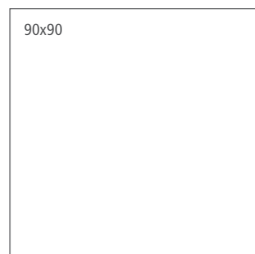

**R4KR** Rewind Corda rettificato



**R4CL** Rewind Corda rettificato

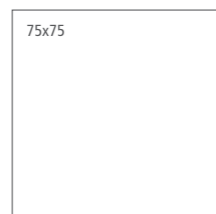

**R4AX** Rewind Corda rettificato

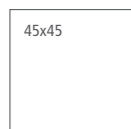

**R4KD** Rewind Corda



**R4LE** Rewind Corda  
7x28

H



H

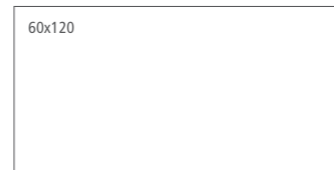

**R4DZ** Rewind Argilla rettificato

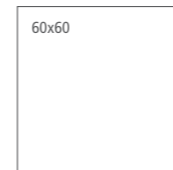

**R4CD** Rewind Argilla rettificato

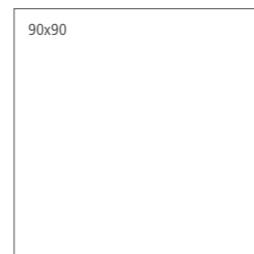

**R4DQ** Rewind Argilla rettificato



**R4CK** Rewind Argilla rettificato

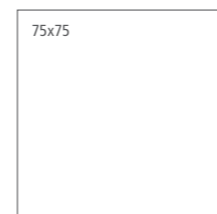

**R4AW** Rewind Argilla rettificato

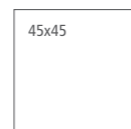

**R4KC** Rewind Argilla

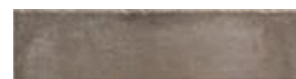

**R4LD** Rewind Argilla  
7x28

H



**R4PM** Rewind Argilla strutturato  
7x28

H



H



**R4KP** Rewind Tabacco rettificato



**R4CC** Rewind Tabacco rettificato

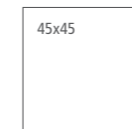

**R4KA** Rewind Tabacco

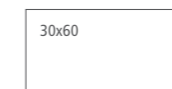

**R4CJ** Rewind Tabacco rettificato

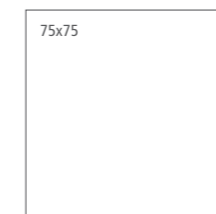

**R4AV** Rewind Tabacco rettificato



**R4LC** Rewind Tabacco  
7x28

G



**R4CS** Rewind Corda  
21x18,2

H



**R4CR** Rewind Argilla  
21x18,2

H



**R4CQ** Rewind Tabacco  
21x18,2

H

# Rewind

90x90 60x120 75x75 60x60 30x60 45x45 21x18,2 7x28

Abbinabile ai fondi / Matching with colours / Mit den Grundfliesen kombinierbar / Peut s'associer aux carreaux de base de couleurs / Puede combinarse con los fondos / Сочетается с фоновой плиткой:  
Vanilla, Polvere, Peltro



**R4DT** Rewind Decoro geometrico Vanilla\*  
21x18,2

Abbinabile ai fondi / Matching with colours / Mit den Grundfliesen kombinierbar / Peut s'associer aux carreaux de base de couleurs / Puede combinarse con los fondos / Сочетается с фоновой плиткой:  
Corda, Tabacco, Argilla



**R4DU** Rewind Decoro geometrico Corda\*  
21x18,2

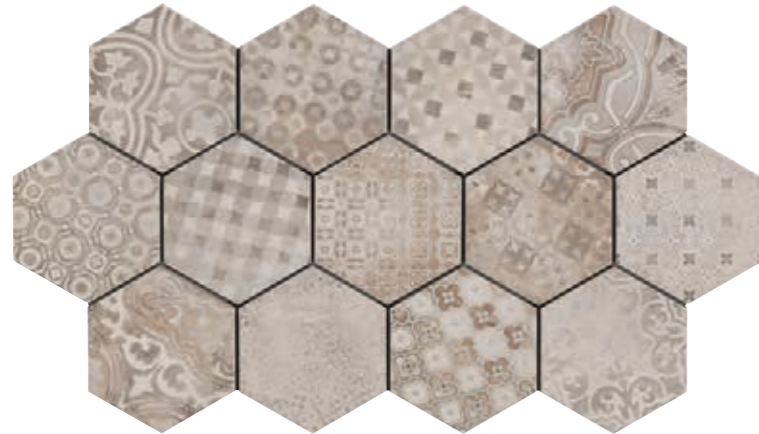

**R4DV** Rewind Decoro cementine\*\*  
21x18,2

**gres fine porcellanato colorato in massa - rettificato monocalibro** / colorbody fine porcelain stoneware - rectified monocaliber/ durchgefärbtes feinsteinzeug - rektifiziert, in einem werkmaß / grès cérame fin coloré dans la masse - rectifié monocalibre / gres porcelánico fino coloreado en toda la masa - rectificado monocalibre / гомогенный мелкозернистый керамогранит - ректифицированный монокалиберный

**gres fine porcellanato colorato in massa** / colorbody fine porcelain stoneware / durchgefärbtes feinsteinzeug / grès cérame fin coloré dans la masse / gres porcelánico fino coloreado en toda la masa / гомогенный мелкозернистый керамогранит

45x45

**gres porcellanato** / porcelain stoneware / feinsteinzeug / grès cérame émaillé / gres porcelánico / керамогранит

**superfici** / surfaces / finitions / oberflächen / superficies / поверхности:  
**naturale/matt + outdoor**

## tech info

★  
18 diversi soggetti / 18 different motifs / 18 verschiedene Motive / 18 sujets différents / 18 temas diferentes / 18 различных рисунка

★★  
13 diversi soggetti / 13 different motifs / 13 verschiedene Motive / 13 sujets différents / 13 temas diferentes / 13 различных рисунка

★★★  
Battiscopa ottenuto da taglio del fondo / Skirting cut from plain tile / Aus Grundfliese geschnittener Sockel / Plinthe obtenue par découpe du fond / Rodapié obtenido mediante corte del fondo /

★★★★  
Battiscopa ottenuto per pressatura Pressed skirting tile / Gepresster Sockel / Plinthe obtenue par pressage / Rodapié obtenido mediante prensado / Плинтус, полученный в результате прессовки

★★★★★  
Assemblato (pag. 592) / Two-piece L-tile (page 592) / Randstein zweiteilig (S. 592) / Assemblé (page 592) / Montado (pág. 592) / Собранный (стр. 592)



Apprezzabili differenze nell'aspetto di superficie e grafica all'interno della stessa produzione. / Clearly distinguishable differences in texture and pattern within the same production run. / Auffällige Unterschiede in Aussehen und Struktur innerhalb der gleichen Produktionscharge. / Différences visibles au niveau de l'aspect et de la fantaisie entre les carreaux du même lot de production. / Diferencias visibles en el aspecto de la superficie y los motivos dentro de un mismo lote de producción. / Заметные отличия вида поверхности и графики в одной и той же партии.



Vedi Appendice pag. 585  
See Appendix page 585  
Siehe Anhang S. 585  
Voir Annexe page 585  
Véase la pág. 585 del Apéndice  
Смотри приложение на стр. 585

**pezzi speciali** / trims / spezialteile / pièces spéciales / piezas especiales / специальные изделия



	R4EU	R4EN	R4KE
Rewind Vanilla	R4EU	R4EN	R4KE
Rewind Polvere	R4EV	R4EP	R4KF
Rewind Peltro	R4EW	R4EQ	R4KG
Rewind Corda	R4EZ	R4ET	R4KK
Rewind Argilla	R4EY	R4ES	R4KJ
Rewind Tabacco	R4EX	R4ER	R4KH



Rewind Vanilla	R4FX
Rewind Polvere	R4FY
Rewind Peltro	R4FZ
Rewind Corda	R4GA
Rewind Argilla	R4G8
Rewind Tabacco	R4G5

**imballi** / packaging / verpackungen / emballages / embalajes / упаковки

Scatole / Box / Karton / Boite / Caja / Коробки	Pallet / Pallet / Palette / Palette / Поддон	
<b>M<sup>2</sup></b>	<b>KG</b>	<b>M<sup>2</sup></b>
<b>KG</b>	<b>M<sup>2</sup></b>	<b>KG</b>

fondi / plain tiles / grundfliesen / fonds / fondos / фоновая плитка					
90x90	2	1,62	40,99	24	38,88 984,00 10,5
60x120	2	1,44	32,82	36	51,84 1181,67 10
75x75	2	1,13	23,81	42	47,25 1000,00 9,5
60x60	3	1,08	23,15	40	43,20 926,05 10
30x60	5	0,90	19,16	48	43,20 919,74 10
45x45	5	1,01	20,00	33	33,41 662,19 9
21x18,2	16	0,46	9,64	100	45,86 963,88 9,5
7x28	50	0,98	19,18	52	50,96 997,11 9
7x28 strutturato	50	0,98	19,18	52	50,96 997,11 9

**decori** / decorative pieces / dekore / décors / decoraciones / декоры

21x18,2	16	0,46	9,64	100	45,86 963,88 9,5
<b>pezzi speciali</b> / trims / spezialteile / pièces spéciales / piezas especiales / специальные изделия					
32,5x60 GR.*****	4	0,78	21,07		
7x75 BT.B.C.	14	10,50 ml	18,87		9,5
7x60 BT.B.C.	15	9,00 ml	18,18		10
8x45 BT.B.C.	30	13,50 ml	21,30		9

# Concept

60x120 30x120 75x75 37,5x75 60x60 30x60 15x60 45x45



R288 Concept Grigio rettificato 60x60  
R2AM Concept Decoro A Grigio 30x60  
R2AN Concept Decoro B Grigio 30x60

concrete effect

# Concept

60x120 30x120 75x75 37,5x75 60x60 30x60 15x60 45x45



Gruppo Bia UNI EN 14411\_G

Beige, Greige, Fango, Grigio, Nero

gres fine porcellanato colorato in massa - rettificato monocalibro / colorbody fine porcelain stoneware - rectified monocaliber / durchgefärbtes feinsteinzeug - rektifiziert, in einem werkmaß / grès cérame fin coloré dans la masse - rectifié monocallibre / gres porcelánico fino coloreado en toda la masa - rectificado monocalibre / гомогенный мелкозернистый керамогранит - ректифицированный монокалиберный

Bianco

gres porcellanato - rettificato monocalibro / porcelain stoneware - rectified monocaliber / feinsteinzeug - rektifiziert, in einem werkmaß / grès cérame émaillé - rectifié monocallibre / gres porcelánico - rectificado monocalibre / керамогранит - ректифицированный монокалиберный

45x45

gres porcellanato / porcelain stoneware / feinsteinzeug / grès cérame émaillé / gres porcelánico / керамогранит

superfici / surfaces / finitions / oberflächen / superficies / поверхности:  
naturale/matt

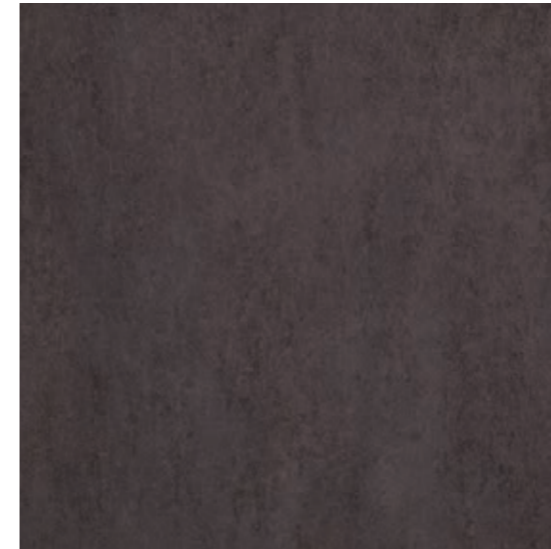

H

H

H

H

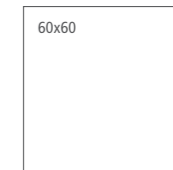
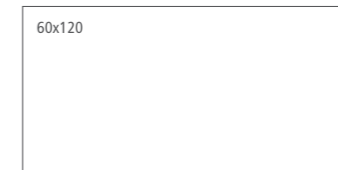
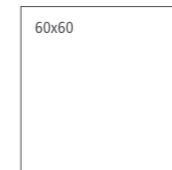
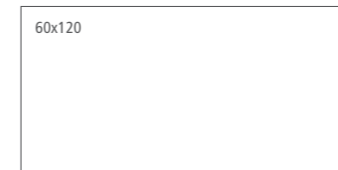
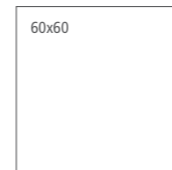
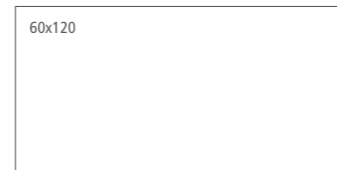
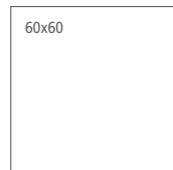
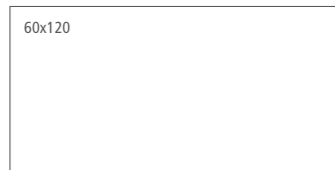

R2GS Concept Beige rettificato

R285 Concept Beige rettificato

R2GT Concept Greige rettificato

R287 Concept Greige rettificato

R2GV Concept Fango rettificato

R28A Concept Fango rettificato

R2GR Concept Bianco rettificato

R284 Concept Bianco rettificato



R2JX Concept Beige rettificato

R28E Concept Beige rettificato

R2JY Concept Greige rettificato

R28F Concept Greige rettificato

R2KA Concept Fango rettificato

R28H Concept Fango rettificato

R2JW Concept Bianco rettificato

R28D Concept Bianco rettificato

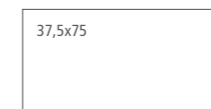
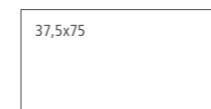
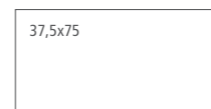
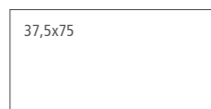

R3HW Concept Beige rettificato

R28L Concept Beige rettificato

R3HX Concept Greige rettificato

R28M Concept Greige rettificato

R3HY Concept Fango rettificato

R28P Concept Fango rettificato

R3HV Concept Bianco rettificato

R28K Concept Bianco rettificato

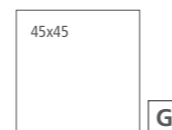
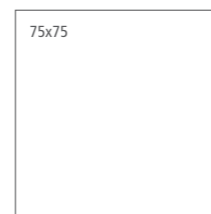
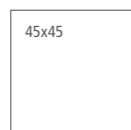
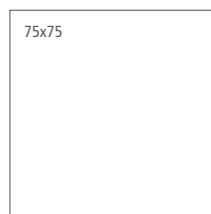

G

G

R3HQ Concept Beige rettificato

R2XV Concept Beige

R3HR Concept Greige rettificato

R2XW Concept Greige

R3HS Concept Fango rettificato

R2WN Concept Fango

R3HP Concept Bianco rettificato

R2XU Concept Bianco

concrete effect



# Concept

60x120 30x120 75x75 37,5x75 60x60 30x60 15x60 45x45

Beige, Greige, Fango, Grigio, Nero

gres fine porcellanato colorato in massa - rettificato monocalibro / colorbody fine porcelain stoneware - rectified monocaliber/ durchgefärbtes feinsteinzeug - rektifiziert, in einem werkmaß / grès cérame fin coloré dans la masse - rectifié monocallibre / gres porcelánico fino coloreado en toda la masa - rectificado monocalibre / гомогенный мелкозернистый керамогранит - ректифицированный монокалиберный

Bianco

gres porcellanato - rettificato monocalibro / porcelain stoneware - rectified monocaliber / feinsteinzeug - rektifiziert, in einem werkmaß / grès cérame émaillé - rectifié monocallibre / gres porcelánico - rectificado monocalibre / керамогранит - ректифицированный монокалиберный

45x45

gres porcellanato / porcelain stoneware / feinsteinzeug / grès cérame émaillé / gres porcelánico / керамогранит

superfici / surfaces / finitions / oberflächen / superficies / поверхности:  
naturale/matt



H

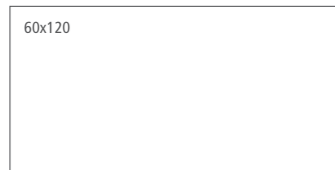

R2GU Concept Grigio rettificato

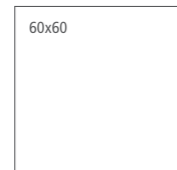

R288 Concept Grigio rettificato



R2JZ Concept Grigio rettificato



R28G Concept Grigio rettificato

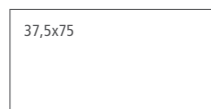

R3HZ Concept Grigio rettificato



R28N Concept Grigio rettificato

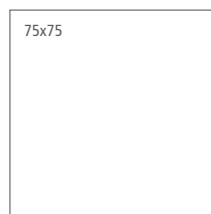

R3HT Concept Grigio rettificato

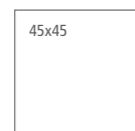

R2XX Concept Grigio

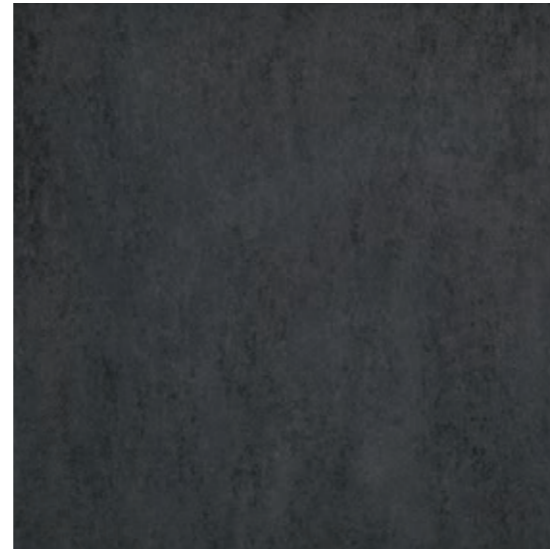

H

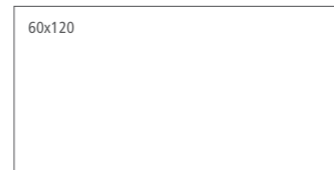

R2GW Concept Nero rettificato

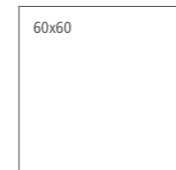

R28C Concept Nero rettificato



R2KC Concept Nero rettificato



R28J Concept Nero rettificato

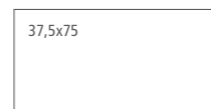

R3JO Concept Nero rettificato



R28Q Concept Nero rettificato

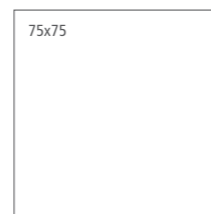

R3HU Concept Nero rettificato

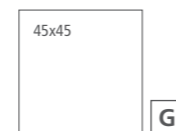

R2WP Concept Nero

G

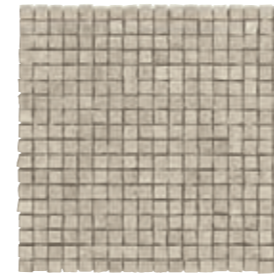

R2AW Concept Mosaico Beige  
30x30

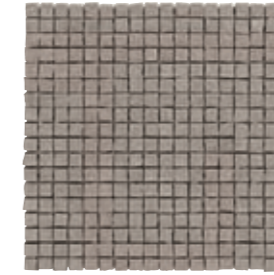

R2AX Concept Mosaico Greige  
30x30

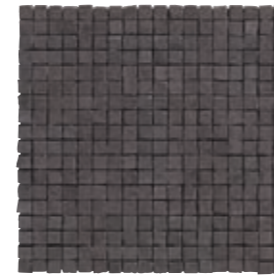

R2AY Concept Mosaico Fango  
30x30

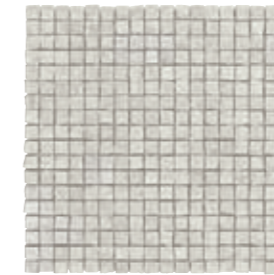

R2AT Concept Mosaico Bianco  
30x30

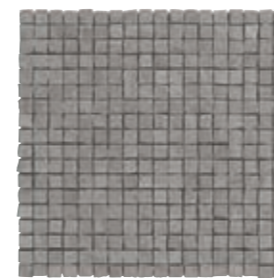

R2AU Concept Mosaico Grigio  
30x30



R2AV Concept Mosaico Nero  
30x30

# Concept

60x120 30x120 75x75 37,5x75 60x60 30x60 15x60 45x45

Beige, Greige, Fango, Grigio, Nero

**gres fine porcellanato colorato in massa - rettificato monocalibro** / colorbody fine porcelain stoneware - rectified monocaliber / durchgefärbtes feinsteinzeug - rektifiziert, in einem werkmaß / grès cérame fin coloré dans la masse - rectifié monocalibre / gres porcelánico fino coloreado en toda la masa - rectificado monocalibre / гомогенный мелкозернистый керамогранит - ректифицированный монокалиберный

Bianco

**gres porcellanato - rettificato monocalibro** / porcelain stoneware - rectified monocaliber / feinsteinzeug - rektifiziert, in einem werkmaß / grès cérame émaillé - rectifié monocalibre / gres porcelánico - rectificado monocalibre / керамогранит - ректифицированный монокалиберный

45x45

**gres porcellanato** / porcelain stoneware / feinsteinzeug / grès cérame émaillé / gres porcelánico / керамогранит

**superfici** / surfaces / finitions / oberflächen / superficies / поверхности: **naturale/matt**



**R2HS** Concept Muretto Beige  
30x60



**R2HT** Concept Muretto Greige  
30x60



**R2HU** Concept Muretto Fango  
30x60



**R2HP** Concept Muretto Bianco  
30x60



**R2HQ** Concept Muretto Grigio  
30x60



**R2HR** Concept Muretto Nero  
30x60

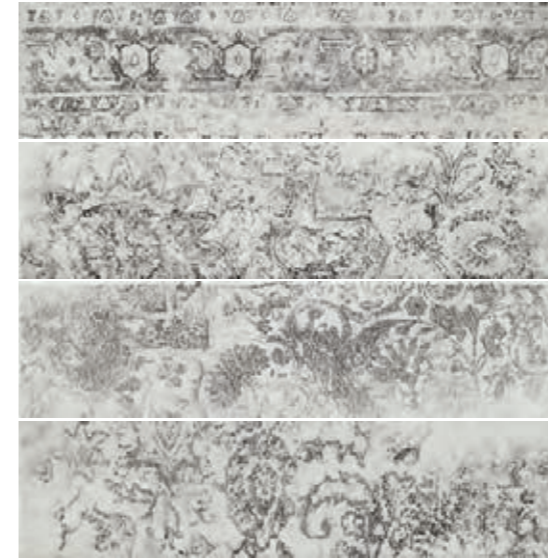

**R2AH** Concept Decoro Bianco\*  
15x60



concrete effect

# Concept

60x120 30x120 75x75 37,5x75 60x60 30x60 15x60 45x45



**RZAP** Concept Decoro A Beige\*\*  
30x60



**RZAQ** Concept Decoro B Beige\*\*  
30x60



**RZAR** Concept Decoro A Greige\*\*  
30x60



**RZAS** Concept Decoro B Greige\*\*  
30x60



**RZAM** Concept Decoro A Grigio\*\*  
30x60



**RZAN** Concept Decoro B Grigio\*\*  
30x60

# Concept

10x10



**R37G** Concept Beige  
10x10



**R37H** Concept Greige  
10x10



**R37J** Concept Fango  
10x10



**R37F** Concept Bianco  
10x10



**R37L** Concept Grigio  
10x10



**R37K** Concept Nero  
10x10



Punto colla  
Glue-dot

Gruppo Bla UNI EN 14411\_G

gres porcellanato / porcelain stoneware / feinsteinzeug / grès cérame émaillé / gres porcelánico / керамогранит

superfici / surfaces / finitions / oberflächen / superficies / поверхности:  
**naturale/matt**

Beige, Greige, Fango, Grigio, Nero

gres fine porcellanato colorato in massa - rettificato monocalibro / colorbody fine porcelain stoneware - rectified monocaliber/ durchgefärbtes feinsteinzeug - rektifiziert, in einem werkmaß / grès cérame fin coloré dans la masse - rectifié monocalibre / gres porcelánico fino coloreado en toda la masa - rectificado monocalibre / гомогенный мелкозернистый керамогранит - ректифицированный монокалиберный

Bianco

gres porcellanato - rettificato monocalibro / porcelain stoneware - rectified monocaliber / feinsteinzeug - rektifiziert, in einem werkmaß / grès cérame émaillé - rectifié monocalibre / gres porcelánico - rectificado monocalibre / керамогранит - ректифицированный монокалиберный

45x45

gres porcellanato / porcelain stoneware / feinsteinzeug / grès cérame émaillé / gres porcelánico / керамогранит

superfici / surfaces / finitions / oberflächen / superficies / поверхности:  
**naturale/matt**

## tech info

\*

4 diversi soggetti / 4 different motifs / 4 verschiedene Motive / 4 sujets différents / 4 temas diferentes / 4 различных рисунка

\*\*

La faccia più decorata (A) è ripetibile; la faccia più vuota (B) viene usata come chiusura. / The more elaborately decorated side (A) can be used recurrently; the plainer side (B) is for use as a closing element. / Die dekorierte Seite (A) ist wiederholbar; die Seite mit weniger Dekor (B) wird als Abschluss verwendet. / Le côté le plus décoré (A) peut être répété; le côté le plus vide (B) est utilisé comme clôture. / La cara más decorada (A) es repetible; la cara más vacía (B) se usa como cierre. / Более украшенная сторона (A) повторяется; более пустая сторона (B) используется в качестве затвора.

\*\*\*

Battiscopa ottenuto da taglio del fondo / Skirting cut from plain tile / Aus Grundfliese geschnittener Sockel / Plinthe obtenue par découpe du fond / Rodapié obtenido mediante corte del fondo / Плинтус, полученный методом нарезания фоновой плитки

\*\*\*\*

Battiscopa ottenuto per pressatura / Pressed skirting tile / Gepresster Sockel / Plinthe obtenue par pressage / Rodapié obtenido mediante prensado / Плинтус, полученный в результате прессовки

\*\*\*\*\*

Assemblato (pag. 592) / Two-piece L-tile (page 592) / Randstein zweiteilig (S. 592) / Assemblé (page 592) / Montado (pág. 592) / Собранный (стр. 592)



Apprezzabili differenze nell'aspetto di superficie e grafica all'interno della stessa produzione. / Clearly distinguishable differences in texture and pattern within the same production run. / Auffällige Unterschiede in Aussehen und Struktur innerhalb der gleichen Produktionscharge. / Différences visibles au niveau de l'aspect et de la fantaisie entre les carreaux du même lot de production. / Diferencias visibles en el aspecto de la superficie y los motivos dentro de un mismo lote de producción. / Заметные отличия вида поверхности и графики в одной и той же партии.

pezzi speciali / trims / spezialteile / pièces spéciales / piezas especiales / специальные изделия



Concept Bianco	R3J1	R2CA	R2WQ	R2CH
Concept Beige	R3J2	R2CE	R2WT	R2CL
Concept Greige	R3J3	R2CF	R2RK	R2CM
Concept Fango	R3J4	R2CG	R2RM	R2CN
Concept Grigio	R3J5	R2CC	R2RL	R2CJ
Concept Nero	R3J7	R2CD	R2RN	R2CK



Mosaico con pellicola trasparente removibile applicata sulla superficie anteriore  
Mosaic with removable clear film applied on the front  
Mosaik mit vorderseitig angebrachter durchsichtiger Abziehfolie  
Mosaïque avec film transparent amovible sur la face avant  
Mosaico con pellicola trasparente estraibile applicada sobre la superficie delantera  
Мозаика с прозрачной снимаемой плёнкой, наносимой на переднюю поверхность

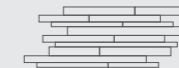

Mosaico assemblato su rete in fibra di vetro  
Mosaic mesh - mounted on fibreglass  
Auf Glasfasernetz geklebtes Mosaik  
Mosaïque montée sur filet en fibre de verre  
Mosaico enmallado sobre fibra de vidrio  
Мозаика, собранная на сетке из стекловолокна

I formati 60x60 e 30x60 rettificati sono modulari se posati con fuga 2 mm. / The 60x60 and 30x60 rectified sizes can be used in modular combinations if laid with 2 mm joint. / Die rektifizierten Formate 60x60 und 30x60 sind bei Verlegung mit 2-mm-Fuge modular. / Les formats 60x60 et 30x60 rectifiés peuvent se combiner s'ils sont posés avec un joint de 2 mm. / Los formatos de 60 x 60 y de 30 x 60 rectificados son modulares si se colocan dejando juntas de 2 mm. / Обрезные форматы 60x60 и 30x60 могут укладываться модульно со швом 2 мм.



Vedi Appendice pag. 585  
See Appendix page 585  
Siehe Anhang S. 585  
Voir Annexe page 585  
Véase la pág. 585 del Apéndice  
Смотри приложение на стр. 585



CONCEPT 60x60  
R284 - R285 - R287 -  
R28A - R288 - R28C

imballi / packaging / verpackungen / emballages / embalajes / упаковки

Scatole / Box / Karton /  
Boite / Caja / Коробки



fondi / plain tiles / grundfliesen / fonds / fondos / фоновая плитка					
60x120	2	1,44	31,47	36	51,84 1132,85 9,5
30x120	3	1,08	22,88	48	51,84 1098,00 9,5
75x75	2	1,12	23,81	42	47,25 1000,00 9,5
37,5x75	4	1,12	23,81	42	47,25 1000,00 9,5
60x60	3	1,08	22,12	40	43,20 884,88 9,5
30x60	6	1,08	21,54	48	51,84 1034,10 9,5
15x60	9	0,81	17,47	64	51,84 1118,20 9,5
45x45	5	1,01	20,50	33	33,41 656,04 9
10x10	96	1,00	14,68	66	66,02 968,73 7

decori / decorative pieces / dekore / décors / decoraciones / декоры					
30x60 muretto	4	0,72	17,74	27	19,44 478,88 9,5
30x60 decoro	4	0,72	12,67		
30x30 mosaico	4	0,36	9,60	80	28,80 767,99 9,5
15x60 decoro	4	0,36	7,27		

pezzi speciali / trims / spezialteile / pièces spéciales / piezas especiales / специальные изделия					
32,5x60 GR.	4	0,78	19,75		
7x75 BT.B.C.	14	10,50 ml	18,42		9,5
7x60 BT.B.C.	15	9,0 ml	15,00		9,5
8x45 BT.B.C.	30	13,50 ml	18,75		9

# Studio

60x120 75x75 60x60 30x60



R4PW Studio Tortora rettificato 60x60  
R4QT Studio Mosaico Tortora 30x30

concrete effect

# Studio

60x120 75x75 60x60 30x60



gres fine porcellanato colorato in massa - rettificato monocalibro / colorbody fine porcelain stoneware - rectified monocaliber / durchgefärbtes feinsteinzeug - rektifiziert, in einem werkmaß / grès cérame fin coloré dans la masse - rectifié monocalibre / gres porcelánico fino coloreado en toda la masa - rectificado monocalibre / гомогенный мелкозернистый керамогранит - ректифицированный монокалиберный

superfici / surfaces / finitions / oberflächen / superficies / поверхности:  
naturale/matt + outdoor



H



R4PP Studio Ghiaccio rettificato

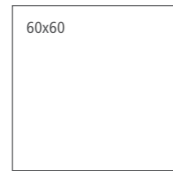

R4PU Studio Ghiaccio rettificato  
R17V Studio Ghiaccio C2 rettificato\*  
R14G Studio Ghiaccio C3 rettificato\*\*

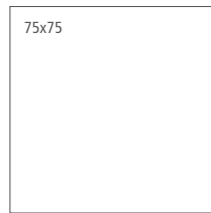

R522 Studio Ghiaccio rettificato



R4QF Studio Ghiaccio rettificato  
R17Q Studio Ghiaccio C2 rettificato\*  
R16S Studio Ghiaccio C3 rettificato\*\*



H



R4PQ Studio Sabbia rettificato



R4PV Studio Sabbia rettificato  
R17Y Studio Sabbia C2 rettificato\*  
R15K Studio Sabbia C3 rettificato\*\*

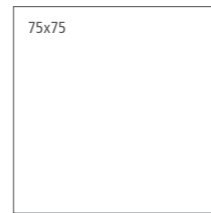

R527 Studio Sabbia rettificato



R4QG Studio Sabbia rettificato  
R17R Studio Sabbia C2 rettificato\*  
R16T Studio Sabbia C3 rettificato\*\*



H



R4PR Studio Tortora rettificato



R4PW Studio Tortora rettificato  
R17Z Studio Tortora C2 rettificato\*  
R16P Studio Tortora C3 rettificato\*\*

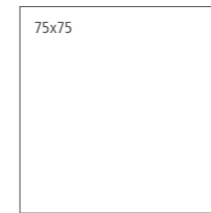

R52A Studio Tortora rettificato



R4QH Studio Tortora rettificato  
R17T Studio Tortora C2 rettificato\*  
R16V Studio Tortora C3 rettificato\*\*



H



R4PS Studio Grigio rettificato

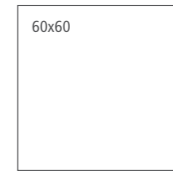

R4PX Studio Grigio rettificato  
R17W Studio Grigio C2 rettificato\*  
R16Q Studio Grigio C3 rettificato\*\*

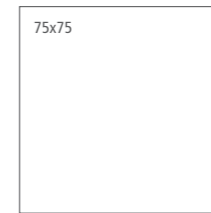

R52C Studio Grigio rettificato



R4QJ Studio Grigio rettificato  
R17S Studio Grigio C2 rettificato\*  
R16U Studio Grigio C3 rettificato\*\*

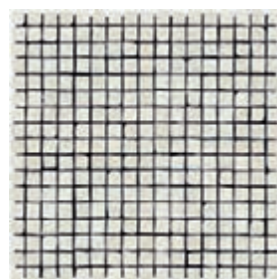

R4QR Studio Mosaico Ghiaccio 30x30



R4QX Studio Mosaico Ghiaccio 30x30



R4QS Studio Mosaico Sabbia 30x30



R4QY Studio Mosaico Sabbia 30x30

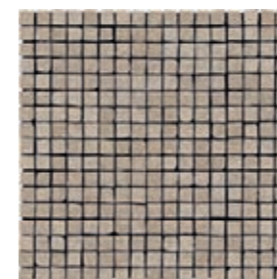

R4QT Studio Mosaico Tortora 30x30



R4QZ Studio Mosaico Tortora 30x30

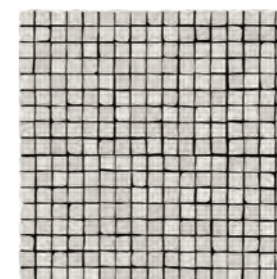

R4QU Studio Mosaico Grigio 30x30

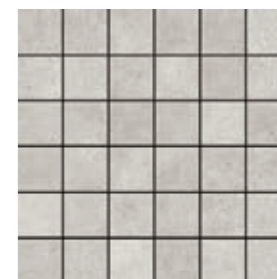

R4RA Studio Mosaico Grigio 30x30

concrete effect

# Studio

60x120 75x75 60x60 30x60

**gres fine porcellanato colorato in massa - rettificato monocalibro** / colorbody fine porcelain stoneware - rectified monocaliber / durchgefärbtes feinsteinzeug - rektifiziert, in einem werkmaß / grès cérame fin coloré dans la masse - rectifié monocalibre / gres porcelánico fino coloreado en toda la masa - rectificado monocalibre / гомогенный мелкозернистый керамогранит - ректифицированный монокалиберный

**superfici** / surfaces / finitions / oberflächen / superficies / поверхности:  
**naturale/matt + outdoor**



H



**R4PT** Studio Antracite rettificato

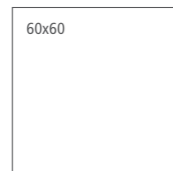

**R4PY** Studio Antracite rettificato  
**R17X** Studio Antracite C2 rettificato\*  
**R16R** Studio Antracite C3 rettificato\*\*

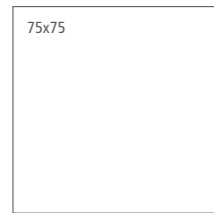

**R52D** Studio Antracite rettificato



**R4QK** Studio Antracite rettificato  
**R17U** Studio Antracite C2 rettificato\*  
**R16W** Studio Antracite C3 rettificato\*\*

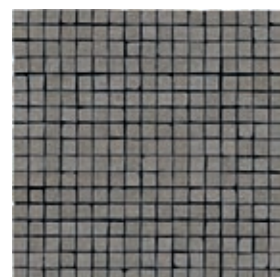

**R4QV** Studio Mosaico Antracite 30x30

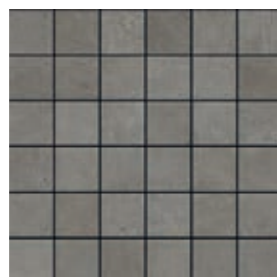

**R4RC** Studio Mosaico Antracite 30x30

## tech info

\*

C2: Classificazione in base alla normativa spagnola UNE – ENV 12633:2003 / Classification according to Spanish standard UNE - ENV 12633: 2003 / Klassifizierung gemäß der spanischen Norm UNE – ENV 12633:2003 / Classification selon la norme espagnole UNE-ENV 12633:2003 / Clasificación con arreglo a la norma española UNE – ENV 12633:2003 / Классификация в соответствии с испанским стандартом UNE – ENV 12633:2003

\*\*

C3: Classificazione in base alla normativa spagnola UNE – ENV 12633:2003 / Classification according to Spanish standard UNE - ENV 12633: 2003 / Klassifizierung gemäß der spanischen Norm UNE – ENV 12633:2003 / Classification selon la norme espagnole UNE-ENV 12633:2003 / Clasificación con arreglo a la norma española UNE – ENV 12633:2003 / Классификация в соответствии с испанским стандартом UNE – ENV 12633:2003

\*\*\*

Battiscopa ottenuto da taglio del fondo / Skirting cut from plain tile / Aus Grundfliese geschnittener Sockel / Plinthe obtenue par découpe du fond / Rodapié obtenido mediante corte del fondo / Плинтус, полученный методом нарезания фоновой плитки



Mosaico assemblato su rete in fibra di vetro  
Mosaic mesh - mounted on fibreglass  
Auf Glasfasernetz geklebtes Mosaik  
Mosaïque montée sur filet en fibre de verre  
Mosaico enmallado sobre fibra de vidrio  
Мозаика, собранная на сетке из стекловолокна



Apprezzabili differenze nell'aspetto di superficie e grafica all'interno della stessa produzione. / Clearly distinguishable differences in texture and pattern within the same production run. / Auffällige Unterschiede in Aussehen und Struktur innerhalb der gleichen Produktionscharge. / Différences visibles au niveau de l'aspect et de la fantaisie entre les carreaux du même lot de production. / Diferencias visibles en el aspecto de la superficie y los motivos dentro de un mismo lote de producción. / Заметные отличия вида поверхности и графики в одной и той же партии.

## pezzi speciali / trims / spezialteile / pièces spéciales / piezas especiales / специальные изделия



BT.B.C.\*\*\*  
7x60



BT.B.C.\*\*\*  
7x75

Studio Ghiaccio	DT0F	DT05
Studio Sabbia	DT0G	DT0A
Studio Tortora	DT0K	DT0C
Studio Grigio	DT0P	DT0D
Studio Antracite	DT0Q	DT0E



Vedi Appendice pag. 585  
See Appendix page 585  
Siehe Anhang S. 585  
Voir Annexe page 585  
Véase la pág. 585 del Apéndice  
Смотри приложение на стр. 585

## imballi / packaging / verpackungen / emballages / embalajes / упаковки

Scatole / Box / Karton / Boite / Caja / Коробки Pallet / Pallet / Palette / Palette / Pallet / Поддон



fondi / plain tiles / grundfliesen / fonds / fondos / фоновая плитка							
60x120	2	1,44	31,47	36	51,84	1132,85	9,5
75x75	2	1,13	23,81	42	47,25	1000,00	9,5
60x60	3	1,08	21,01	40	43,20	840,50	9,5
60x60 C2/C3	3	1,08	21,01	40	43,20	840,50	9,5
30x60	6	1,08	21,07	48	51,84	1011,41	9,5
30x60 C2/C3	6	1,08	21,07	48	51,84	1011,41	9,5

decori / decorative pieces / dekore / décors / decoraciones / декоры							
60x60 decoro	3	1,08	21,88	40	43,20	875,14	9,5
30x30 mosaico 5x5	4	0,36	7,51	80	28,80	600,66	9,5

pezzi speciali / trims / spezialteile / pièces spéciales / piezas especiales / специальные изделия						
7x75 BT.B.C.	14	10,50 ml	18,87			9,5
7x60 BT.B.C.	15	9,00 ml	17,47			9,5

concrete effect

# Epoca

60x60 30x30 15x30 15x15 21x18,2



R55D Epoca Cotto rosso 15x15  
R557 Epoca Cotto rosso 15x30  
R54Y Epoca Cotto rosso 30x30  
R55V Epoca Decoro cementine Cotto scuro 21x18,2

concrete effect

# Epoca

60x60 30x30 15x30 15x15 21x18,2



G

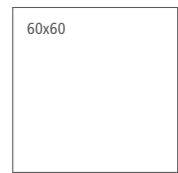

**R02J** Epoca Odra rettificato



**R54V** Epoca Odra



**R558** Epoca Odra



**R54Z** Epoca Odra  
**R55E** Epoca Odra Strutturato



**R55P** Epoca Odra  
21x18,2

G



G

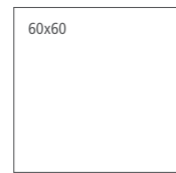

**R02K** Epoca Rosa rettificato



**R54W** Epoca Rosa



**R55A** Epoca Rosa



**R551** Epoca Rosa  
**R55F** Epoca Rosa Strutturato



**R55Q** Epoca Rosa  
21x18,2

G



G

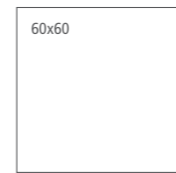

**R02L** Epoca Cotto scuro rettificato



**R54X** Epoca Cotto scuro



**R55C** Epoca Cotto scuro



**R553** Epoca Cotto scuro  
**R55G** Epoca Cotto scuro Strutturato



**R55R** Epoca Cotto scuro  
21x18,2

G



G



**R54Y** Epoca Cotto rosso



**R557** Epoca Cotto rosso  
**R55H** Epoca Cotto rosso Outdoor



**R55D** Epoca Cotto rosso



**R55S** Epoca Cotto rosso  
21x18,2

G

concrete effect



# Epoca

60x60 30x30 15x30 15x15 21x18,2



**R03D** Epoca Decoro Anticato Ocra rettificato\*  
60x60



**R03Q** Epoca Decoro Tappeto Ocra  
30x30

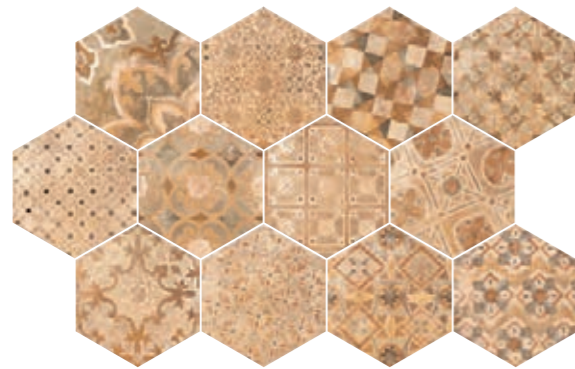

**R55T** Epoca Decoro cementine Ocra\*\*  
21x18,2

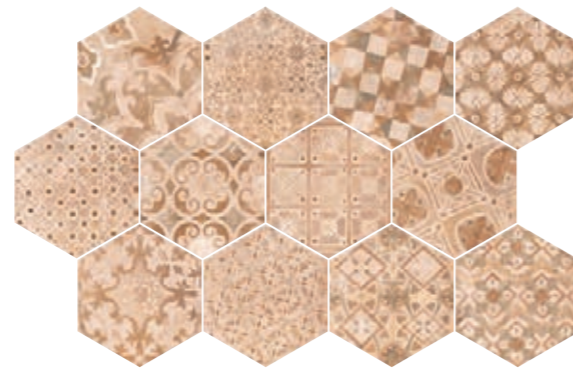

**R55U** Epoca Decoro cementine Rosa\*\*  
21x18,2

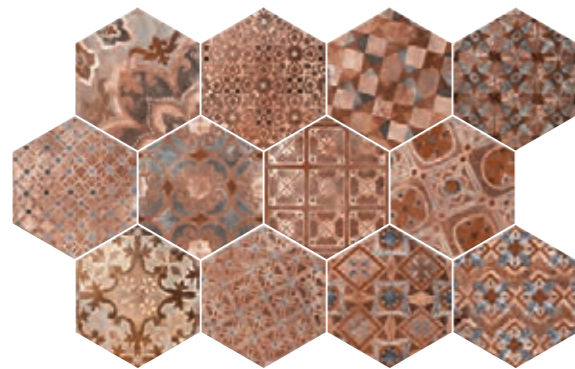

**R55V** Epoca Decoro cementine Cotto scuro\*\*  
21x18,2

Abbinabili ai fondi / Matching with colours / Mit den Grundfliesen kombinierbar / Peut s'associer aux carreaux de base de couleurs / Puede combinarse con los fondos / Сочетается с фоновой плиткой:  
Ocra, Cotto rosso



**R03R** Epoca F. Ocra  
13,8x30



**R03S** Epoca AN. Ocra  
13,8x13,8



**R03T** Epoca Decoro Cabochon Ocra  
6,9x6,9

## tech info

\*

2 diversi soggetti / 2 different motifs / 2 verschiedene Motive / 2 sujets différents / 2 temas diferentes / 18 различных рисунка

\*\*

12 diversi soggetti / 12 different motifs / 12 verschiedene Motive / 12 sujets différents / 12 temas diferentes / 12 различных рисунка

\*\*\*

Battiscopa ottenuto per pressatura / Pressed skirting tile / Gepresster Sockel / Plinthe obtenue par pressage / Rodapié obtenido mediante prensado / Плинтус, полученный в результате прессовки

pezzi speciali / trims / spezialteile / pièces spéciales / piezas especiales / специальные изделия

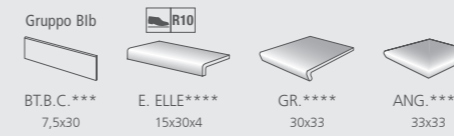

Epoca Ocra	R03L	R03U	R03Y	R05M
Epoca Rosa	R03M	R03V	R03Z	R05N
Epoca Cotto scuro	R03N	R03W	R044	R05P
Epoca Cotto rosso	R03P	R03X	R047	R05Q

Per le pavimentazioni esterne non protette, Ragno consiglia di creare una pendenza  $\geq 1,5\%$  sulla superficie calpestabile allo scopo di limitare il formarsi di ristagni d'acqua localizzati. Nel caso in cui questi ristagni permangano sulla superficie delle piastrelle nonostante una posa a regola d'arte, è necessario intervenire meccanicamente con l'utilizzo di scope o aspira-liquidi. / For unprotected outdoor pavings, Ragno recommends the creation of a gradient of  $\geq 1.5\%$  on the finished surface, to prevent the formation of patches of standing water. In the event that standing water persists on the surface of the tiles in spite of correct installation, it must be removed mechanically with the aid of brooms or wet-and-dry vacuum cleaners. / Zur Unterbindung von punktueller Stauwasserbildung bei Belägen in ungeschützten Außenbereichen, empfiehlt die Ragno die Ausbildung eines Gefälles  $\geq 1,5\%$  auf der Trittlfläche. Sollte trotz fachgerechter Verlegung Stauwasser auf der Fliesenoberfläche zurückbleiben, ist dessen mechanische Entfernung mit Hilfe eines Besens oder Nasssaugers erforderlich. / Pour des sols extérieurs non protégés, Ragno conseille de créer une inclinaison  $\geq 1,5\%$  sur la surface de piétement en vue de limiter la stagnation localisée de l'eau. Si, malgré une pose dans les règles de l'art, cette stagnation devait persister à la surface des carreaux, une intervention mécanique, au moyen de balais et d'aspirateurs de liquides, est alors nécessaire. / En el caso de pavimentaciones exteriores no protegidas, Ragno recomienda crear una pendiente  $\geq 1,5\%$  en la superficie transitable para limitar la formación de depósitos localizados de agua estancada. En caso de que estos depósitos de agua permanezcan en la superficie del azulejo, aun cuando la colocación se haya realizado correctamente, será necesario intervenir mecánicamente empleando un cepillo o un aspirador de líquidos. / Для наружных незащищенных полов Ragno рекомендует создавать уклон  $\geq 1,5\%$  на пешеходной поверхности для снижения образования локальных застоев воды. В случае, если застои воды образуются на плитке несмотря на правильную укладку, необходимо прибегать к использованию механических средств, таких как щетки или же аппараты для сбора жидкостей.

\*\*\*\*

Monolitico piegato (pag. 592) / One-piece bent I-tile (page 592) / Schenkelplatte einteilig, gebogen (S. 592) / Monolithique cintré (page 592) / Monolitico doblado (pág. 592) / Монолитный гнутый (стр. 592)



Significativa variazione di aspetto superficiale, grafica e colore da piastrella a piastrella e all'interno della stessa piastrella. Si consiglia di visionare la gamma cromatica prima della selezione del materiale. / Significant variation in texture, pattern and colour from tile to tile within the same production run. The colour range should be viewed before selecting the material. / Bedeutende Variation in Aussehen, Struktur und Farbe von Fliese zu Fliese und in ein und derselben Fliese. Es wird empfohlen, das Farbsortiment vor der Auswahl des Materials zu prüfen. / Variation significative au niveau de l'aspect, de la fantaisie et de la couleur entre les carreaux et au sein d'un même carreau. Il est recommandé de consulter la gamme des couleurs avant de sélectionner le matériel. / Variación considerable en el aspecto superficial, los motivos y el color entre un azulejo y otro y dentro del propio azulejo. Es aconsejable visualizar la gama cromática antes de seleccionar el material. / Значительные отличия вида поверхности, графики и цвета у разных плиток и на одной и той же плитке. Перед отбором материала рекомендуется просмотреть цветовую гамму.

imballi / packaging / verpackungen / emballages / embalajes / упаковки

	Scatole / Box / Karton / Boite / Caja / Коробки			Pallet / Pallet / Palette / Palette / Pallet / Поддон		
	M <sup>2</sup>	KG	M <sup>2</sup>	KG	≠ mm	

fondi / plain tiles / grundfliesen / fonds / fondos / фоновая плитка						
60x60	3	1,08	23,38	40	43,20	935,32
30x30	14	1,26	23,56	40	50,40	942,58
15x30	20	0,90	16,83	64	57,60	1077,24
15x15	40	0,90	16,83	64	57,60	1077,24
21x18,2	16	0,46	9,53	100	45,85	953,15

decori / decorative pieces / dekore / décors / decoraciones / декоры						
60x60	3	1,08	27,00	40	43,20	1079,98
30x30	4	0,36	22,42			
21x18,2	16	0,46	9,42	100	45,86	942,29
15x30	F	4	0,18	5,57		
15x15	AN	4	0,09	2,19		
6,9x6,9		8	0,039	64,17		

pezzi speciali / trims / spezialteile / pièces spéciales / piezas especiales / специальные изделия						
7,5x30	BT.B.C.	50	15 ml	19,79		8
15x30x4	E.ELLE	6	0,27	6,87		
30x33	GR.	6	0,594	175,71		
33x33	ANG.	2	0,22	7,43		

# Jazz

60x60 30x60

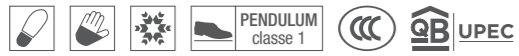

ROZD Jazz White 60x60

Gruppo Bia UNI EN 14411\_G

gres porcellanato - rettificato monocalibro / porcelain stoneware - rectified monocaliber / feinsteinzeug - rektifiziert, in einem werkmaß / grès cérame émaillé - rectifié monocalibre / gres porcelánico - rectificado monocalibre / керамогранит - ректифицированный монокалиберный

45x45

gres porcellanato / porcelain stoneware / feinsteinzeug / grès cérame émaillé / gres porcelánico / керамогранит

superfici / surfaces / finitions / oberflächen / superficies / поверхности:  
naturale/matt



G



ROZD Jazz White rettificato



ROYQ Jazz White rettificato



G

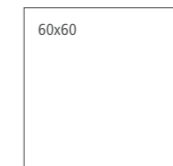

ROZF Jazz Beige rettificato



ROYS Jazz Beige rettificato

concrete effect

# Jazz

60x60 30x60

gres porcellanato - rettificato monocalibro / porcelain stoneware - rectified monocalibre / feinsteinzeug - rektifiziert, in einem werkmaß / grès cérame émaillé - rectifié monocalibre / gres porcelánico - retificado monocalibre / керамогранит - ректифицированный монокалиберный

45x45

gres porcellanato / porcelain stoneware / feinsteinzeug / grès cérame émaillé / gres porcelánico / керамогранит

superfici / surfaces / finitions / oberflächen / superficies / поверхности:  
naturale/matt



G

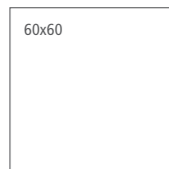

ROZG Jazz Brown rettificato



ROYT Jazz Brown rettificato



G



ROZE Jazz Grey rettificato



ROYR Jazz Grey rettificato

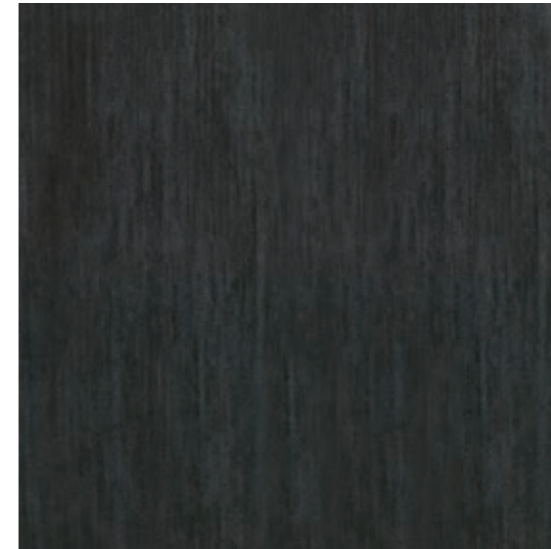

G

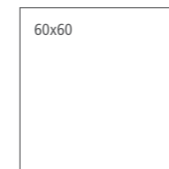

ROZH Jazz Black rettificato



ROYU Jazz Black rettificato

R1FE Listello Metallo •  
2x60

## tech info

\*

Battiscopa ottenuto da taglio del fondo  
Skirting cut from plain tile  
Aus Grundfliese geschnittener Sockel  
Plinthe obtenue par découpe du fond  
Rodapié obtenido mediante corte del fondo  
Плинтус, полученный методом нарезания фоновой плитки

\* \*

Battiscopa ottenuto per pressatura  
Pressed skirting tile  
Gepresster Sockel  
Plinthe obtenue par pressage  
Rodapié obtenido mediante prensado  
Плинтус, полученный в результате прессовки

I formati 60x60 e 30x60 rettificati sono modulari se posati con fuga 2 mm. / The 60x60 and 30x60 rectified sizes can be used in modular combinations if laid with 2 mm joint. / Die rektifizierten Formate 60x60 und 30x60 sind bei Verlegung mit 2-mm-Fuge modular. / Les formats 60x60 et 30x60 rectifiés peuvent se combiner s'ils sont posés avec un joint de 2 mm. / Los formatos de 60 x 60 y de 30 x 60 retificados son modulares si se colocan dejando juntas de 2 mm. / Обрезные форматы 60x60 и 30x60 могут укладываться модульно со швом 2 мм.



Vedi Appendice pag. 585  
See Appendix page 585  
Siehe Anhang S. 585  
Voir Annexe page 585  
Véase la pág. 585 del Apéndice  
Смотри приложение на стр. 585



JAZZ 60x60  
R0ZD - R0ZF - R0ZG - R0ZE - R0ZH

pezzi speciali / trims / spezialteile / pièces spéciales / piezas especiales / специальные изделия

BT.B.C.\*  
7x60

Jazz White	R1DJ
Jazz Beige	R1DL
Jazz Brown	R1DM
Jazz Grey	R1DK
Jazz Black	R1DN

imballi / packaging / verpackungen / emballages / embalajes / упаковки

Scatole / Box / Karton / Boite / Caja / Коробки  
Pallet / Pallet / Palette / Palette / Pallet / Поддон

	M <sup>2</sup>	KG		M <sup>2</sup>	KG	≠	mm
--	----------------	----	--	----------------	----	---	----

fondi / plain tiles / grundfliesen / fonds / fondos / фоновая плитка							
60x60	3	1,08	21,51	40	43,20	860,30	9,5
30x60	6	1,08	21,26	48	51,84	1020,24	9,5
decori / decorative pieces / dekore / décors / decoraciones / декоры							
2x60	L	6	0,07	1,90			
pezzi speciali / trims / spezialteile / pièces spéciales / piezas especiales / специальные изделия							
7x60	BT.B.C.	15	9,00 ml	15,32			9,5



## WOOD EFFECT

- Gres Effetto Legno*
- Wood Effect Stoneware*
- Holzoptik Feinsteinzeug*
- Grès Effet Bois*
- Gres de Efecto Madera*
- Керамогранит С Эффектом Дерева*



# Woodsense

25x150 19x150 20x120



R7FN Woodsense Avorio rettificato 19x150

wood effect

# Woodsense

25x150 19x150 20x120



**R7FU** Woodsense Avorio rettificato  
**R7G0** Woodsense Avorio Grip rettificato



**R7FN** Woodsense Avorio rettificato



**R7EV** Woodsense Avorio rettificato



**R7FV** Woodsense Beige rettificato  
**R7GA** Woodsense Beige Grip rettificato



**R7FQ** Woodsense Beige rettificato



**R7EW** Woodsense Beige rettificato

G

G

Gruppo Bia UNI EN 14411\_G  
gres fine porcellanato colorato in massa - rettificato monocalibro / colorbody fine porcelain stoneware - rectified monocaliber / durchgefärbtes feinsteinzeug - rektifiziert, in einem werkmaß / grès cérame fin coloré dans la masse - rectifié monocalibre / gres porcelánico fino coloreado en toda la masa - rectificado monocalibre / гомогенный мелкозернистый керамогранит - ректифицированный монокалиберный

superfici / surfaces / finitions / oberflächen / superficies / поверхности:  
naturale/matt + outdoor

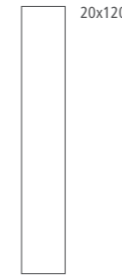

**R7FW** Woodsense Marrone rettificato  
**R7GC** Woodsense Marrone Grip rettificato



**R7FR** Woodsense Marrone rettificato



**R7EX** Woodsense Marrone rettificato

G

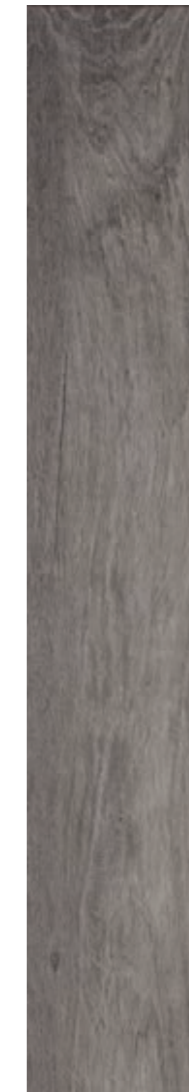

**R7FX** Woodsense Grigio rettificato  
**R7GD** Woodsense Grigio Grip rettificato

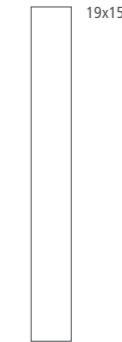

**R7FS** Woodsense Grigio rettificato



**R7EY** Woodsense Grigio rettificato

G

wood effect

## tech info

\*

Battiscopa ottenuta da taglio del fondo  
Skirting cut from plain tile  
Aus Grundfliese geschnittener Sockel  
Plinthe obtenue par découpe du fond  
Rodapié obtenido mediante corte del fondo  
Плинтус, полученный методом нарезания фоновой плитки



Significativa variazione di aspetto superficiale, grafica e colore da piastrella a piastrella e all'interno della stessa piastrella. Si consiglia di visionare la gamma cromatica prima della selezione del materiale. / Significant variation in texture, pattern and colour from tile to tile within the same production run. The colour range should be viewed before selecting the material. / Bedeutende Variation in Aussehen, Struktur und Farbe von Fliese zu Fliese und in ein und derselben Fliese. Es wird empfohlen, das Farbsortiment vor der Auswahl des Materials zu prüfen. / Variation significative au niveau de l'aspect, de la fantaisie et de la couleur entre les carreaux et au sein d'un même carreau. Il est recommandé de consulter la gamme des couleurs avant de sélectionner le matériel. / Variación considerable en el aspecto superficial, los motivos y el color entre un azulejo y otro y dentro del propio azulejo. Es aconsejable visualizar la gama cromática antes de seleccionar el material. / Значительные отличия вида поверхности, графики и цвета у разных плиток и на одной и той же плитке. Перед отбором материала рекомендуется посмотреть цветовую гамму.

## pezzi speciali / trims / spezialteile / pièces spéciales / piezas especiales / специальные изделия



	BT.B.C.* 6x60	BT.B.C.* 6x75
Woodsense Avorio	R8CH	R8CU
Woodsense Beige	R8CK	R8CV
Woodsense Marrone	R8CL	R8CW
Woodsense Grigio	R8CM	R8CX

## imballi / packaging / verpackungen / emballages / embalajes / упаковки

Scatole / Box / Karton / Boite / Caja / Коробки

Pallet / Pallet / Palette / Palette / Поддон



fondi / plain tiles / grundfliesen / fonds / fondos / фоновая плитка							
25x150	rettificato	3	1,13	24,90	45	50,63	1120,40
19x150	rettificato	4	1,14	24,75	48	54,72	1188,00
20x120	rett. / grip	3	0,72	15,57	60	43,20	934,00

pezzi speciali / trims / spezialteile / pièces spéciales / piezas especiales / специальные изделия							
6x60	BT.B.C.	13	7,80 ml	15,00			9,5
6x75	BT.B.C.	13	9,75 ml	20,00			9,5

# Woodspace

25x150 20x120



R63F Woodspace Beige rettificato 25x150

# Woodspace

25x150 20x120



Gruppo Bia UNI EN 14411\_G

gres fine porcellanato colorato in massa - rettificato monocalibro / colorbody fine porcelain stoneware - rectified monocaliber / durchgefärbtes feinsteinzeug - rektifiziert, in einem werkmaß / grès cérame fin coloré dans la masse - rectifié monocalibre / gres porcelánico fino coloreado en toda la masa - rectificado monocalibre / гомогенный мелкозернистый керамогранит - ректифицированный монокалиберный



superfici / surfaces / finitions / oberflächen / superficies / поверхности: naturale/matt



R63K Woodspace Bianco rettificato



R63E Woodspace Bianco rettificato

G

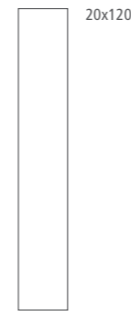

R63L Woodspace Beige rettificato



R63F Woodspace Beige rettificato

G



R63N Woodspace Tortora rettificato



R63H Woodspace Tortora rettificato

G

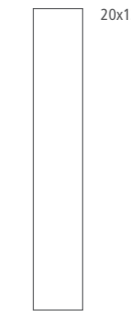

R63M Woodspace Marrone rettificato

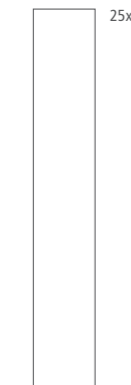

R63G Woodspace Marrone rettificato

G

## tech info

★

Battiscopa ottenuto da taglio del fondo  
Skirting cut from plain tile  
Aus Grundfliese geschchnittener Sockel  
Plinthe obtenue par découpe du fond  
Rodapié obtenido mediante corte del fondo  
Глинтус, полученный методом нарезания фоновой плитки

★★

Assemblato (pag. 592) / Two-piece L-tile (page 592) / Randstein zweiteilig (S. 592) / Assemblé (page 592) / Montado (pág. 592) / Собранный (стр. 592)



Significativa variazione di aspetto superficiale, grafica e colore da piastrella a piastrella e all'interno della stessa piastrella. Si consiglia di visionare la gamma cromatica prima della selezione del materiale. / Significant variation in texture, pattern and colour from tile to tile within the same production run. The colour range should be viewed before selecting the material. / Bedeutende Variation in Aussehen, Struktur und Farbe von Fliese und in ein und derselben Fliese. Es wird empfohlen, das Farbsortiment vor der Auswahl des Materials zu prüfen. / Variation significative au niveau de l'aspect, de la fantaisie et de la couleur entre les carreaux et au sein d'un même carreau. Il est recommandé de consulter la gamme des couleurs avant de sélectionner le matériel. / Variación considerable en el aspecto superficial, los motivos y el color entre un azulejo y otro y dentro del propio azulejo. Es aconsejable visualizar la gama cromática antes de seleccionar el material. / Значительные отличия вида поверхности, графики и цвета у разных плиток и на одной и той же плитке. Перед отбором материала рекомендуется просмотреть цветовую гамму.

## pezzi speciali / trims / spezialteile / pièces spéciales / piezas especiales / специальные изделия

	BT.B.C.* 7x60	BT.B.C.* 7x75
Woodspace Bianco	R6PW	R6QC
Woodspace Beige	R6PX	R6QD
Woodspace Tortora	R6PZ	R6QF
Woodspace Marrone	R6PY	R6QE

	GR.** 32,5x120x4	GR.** 32,5x150x4
Woodspace Bianco	R6QH	R6QN
Woodspace Beige	R6QJ	R6QP
Woodspace Tortora	R6QL	R6QR
Woodspace Marrone	R6QK	R6QQ

## imballi / packaging / verpackungen / emballages / embalajes / упаковки

		Scatole / Box / Karton / Boite / Caja / Коробки			Pallet / Pallet / Palette / Palette / Поддон			≠ mm
		M2	KG		M2	KG		
<b>fondi / plain tiles / grundfliesen / fonds / fondos / фоновая плитка</b>								
25x150	rettificato	3	1,13	27,29	45	50,63	1228,42	10,5
20x120	rettificato	3	0,72	18,38	60	43,20	1103,00	10,5
<b>pezzi speciali / trims / spezialteile / pièces spéciales / piezas especiales / специальные изделия</b>								
6x60	BT.B.C.	14	8,40	13,00				10,5
7x75	BT.B.C.	13	9,75	19,50				10,5
32,5x120x4	GR.	2	0,78	17,70				
32,5x150x4	GR.	2	0,98	25,90				

wood effect



# Woodliving

30x120 20x120 15x120



Gruppo Bia UNI EN 14411\_G

gres fine porcellanato colorato in massa - rettificato monocalibro / colorbody fine porcelain stoneware - rectified monocaliber / durchgefärbtes feinsteinzeug - rektifiziert, in einem werkmaß / grès cérame fin coloré dans la masse - rectifié monocalibre / gres porcelánico fino coloreado en toda la masa - rectificado monocalibre / гомогенный мелкозернистый керамогранит - ректифицированный монокалиберный

superfici / surfaces / finitions / oberflächen / superficies / поверхности: naturale/matt



R3ZZ Woodliving Rovere Biondo rettificato 30x120  
R40F Woodliving Rovere Biondo rettificato 20x120  
R40L Woodliving Rovere Biondo rettificato 15x120

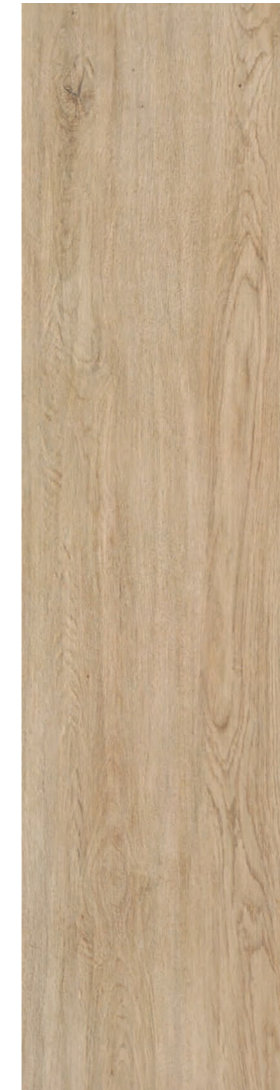

G

15x120

R40L Woodliving Rovere Biondo rettificato

20x120

R40F Woodliving Rovere Biondo rettificato

30x120

R3ZZ Woodliving Rovere Biondo rettificato



G

15x120

R40K Woodliving Rovere Scuro rettificato

20x120

R40E Woodliving Rovere Scuro rettificato

30x120

R3ZY Woodliving Rovere Scuro rettificato

wood effect

# Woodliving

30x120 20x120 15x120



gres fine porcellanato colorato in massa - rettificato monocalibro / colorbody fine porcelain stoneware - rectified monocaliber / durchgefärbtes feinsteinzeug - rektifiziert, in einem werkmaß / grès cérame fin coloré dans la masse - rectifié monocalibre / gres porcelánico fino coloreado en toda la masa - rectificado monocalibre / гомогенный мелкозернистый керамогранит - ректифицированный монокалиберный

superfici / surfaces / finitions / oberflächen / superficies / поверхности:  
naturale/matt



R40J Woodliving Rovere Tortora rettificato

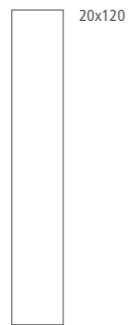

R40D Woodliving Rovere Tortora rettificato

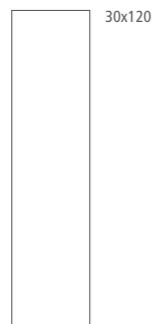

R3ZX Woodliving Rovere Tortora rettificato

G



R40G Woodliving Rovere Ghiaccio rettificato

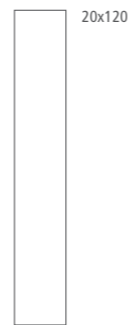

R40A Woodliving Rovere Ghiaccio rettificato



R3ZV Woodliving Rovere Ghiaccio rettificato

G

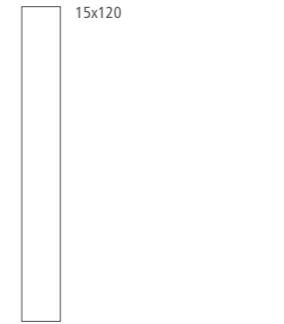

R40H Woodliving Rovere Fumo rettificato

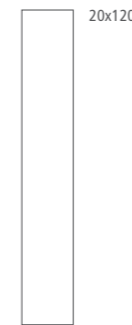

R40C Woodliving Rovere Fumo rettificato



R3ZW Woodliving Rovere Fumo rettificato

G

wood effect

## tech info

\*  
Battiscopa ottenuto da taglio del fondo  
Skirting cut from plain tile  
Aus Grundfliese geschnittener Sockel  
Plinthe obtenue par découpe du fond  
Rodapié obtenido mediante corte del fondo  
Глинтус, полученный методом нарезания фоновой плитки

\* \*  
Assemblato (pag. 592) / Two-piece L-tile (page 592) / Randstein zweiteilig (S. 592) /  
Assemblé (page 592) / Montado (pág. 592) / Собранный (стр. 592)



Apprezzabili differenze nell'aspetto di superficie e grafica all'interno della stessa produzione. / Clearly distinguishable differences in texture and pattern within the same production run. / Auffällige Unterschiede in Aussehen und Struktur innerhalb der gleichen Produktionscharge. / Différences visibles au niveau de l'aspect et de la fantaisie entre les carreaux du même lot de production. / Diferencias visibles en el aspecto de la superficie y los motivos dentro de un mismo lote de producción. / Заметные отличия вида поверхности и графики в одной и той же партии.

## pezzi speciali / trims / spezialteile / pièces spéciales / piezas especiales / специальные изделия

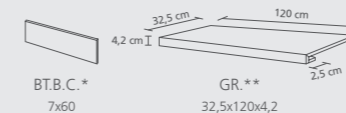

Woodliving Rovere Ghiaccio	R40S	R40X
Woodliving Rovere Fumo	R40T	R40Y
Woodliving Rovere Tortora	R40U	R40Z
Woodliving Rovere Scuro	R40V	R41A
Woodliving Rovere Biondo	R40W	R41C

## imballi / packaging / verpackungen / emballages / embalajes / упаковки

Scatole / Box / Karton / Boite / Caja / Коробки	Pallet / Pallet / Palette / Palette / Pallet / Поддон
M <sup>2</sup> KG	M <sup>2</sup> KG  mm

fondi / plain tiles / grundfliesen / fonds / fondos / фоновая плитка								
30x120	rettificato	3	1,08	22,99	48	51,84	1103,52	9,5
20x120	rettificato	3	0,72	15,57	60	43,20	934,00	9,5
15x120	rettificato	6	1,08	22,68	40	43,20	907,00	9,5

pezzi speciali / trims / spezialteile / pièces spéciales / piezas especiales / специальные изделия								
7x60	BT.B.C.	14	8,40	ml	14,73			9,5
32,5x120x4,2	GR.	2	0,78		17,69			

# Woodtale

30x120 20x120 15x120



Gruppo Bia UNI EN 14411\_G

gres fine porcellanato colorato in massa - rettificato monocalibro / colorbody fine porcelain stoneware - rectified monocaliber / durchgefärbtes feinsteinzeug - rektifiziert, in einem werkmaß / grès cérame fin coloré dans la masse - rectifié monocalibre / gres porcelánico fino coloreado en toda la masa - rectificado monocalibre / гомогенный мелкозернистый керамогранит - ректифицированный монокалиберный

superfici / surfaces / finitions / oberflächen / superficies / поверхности: naturale/matt



R4TJ Woodtale Nocciola rettificato 30x120  
R4TP Woodtale Nocciola rettificato 20x120  
R4TU Woodtale Nocciola rettificato 15x120



H



15x120

R4TS Woodtale Betulla rettificato



20x120

R4TM Woodtale Betulla rettificato



30x120

R4TG Woodtale Betulla rettificato



H

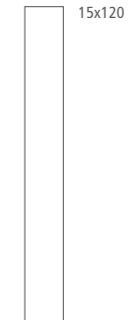

15x120

R4TT Woodtale Miele rettificato

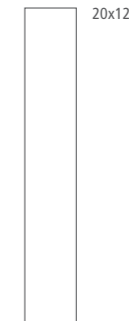

20x120

R4TN Woodtale Miele rettificato



30x120

R4TH Woodtale Miele rettificato

wood effect

# Woodtale

30x120 20x120 15x120



gres fine porcellanato colorato in massa - rettificato monocalibro / colorbody fine porcelain stoneware - rectified monocaliber / durchgefärbtes feinsteinzeug - rektifiziert, in einem werkmaß / grès cérame fin coloré dans la masse - rectifié monocalibre / gres porcelánico fino coloreado en toda la masa - rectificado monocalibre / гомогенный мелкозернистый керамогранит - ректифицированный монокалиберный

superfici / surfaces / finitions / oberflächen / superficies / поверхности:  
naturale/matt



15x120

R4TU Woodtale Nociola rettificato



20x120

R4TP Woodtale Nociola rettificato



30x120

R4TJ Woodtale Nociola rettificato

H



15x120

R4TV Woodtale Quercia rettificato



20x120

R4TQ Woodtale Quercia rettificato

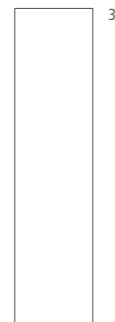

30x120

R4TK Woodtale Quercia rettificato

H



15x120

R4TW Woodtale Noce rettificato



20x120

R4TR Woodtale Noce rettificato



30x120

R4TL Woodtale Noce rettificato

H

## tech info

\*

Battiscopa ottenuto da taglio del fondo / Skirting cut from plain tile / Aus Grundfliese geschnittener Sockel / Plinthe obtenue par découpe du fond / Rodapié obtenido mediante corte del fondo / Плинтус, полученный методом нарезания фоновой плитки

\*\*

Assemblato (pag. 592) / Two-piece L-tile (page 592) / Randstein zweiteilig (S. 592) / Assemblé (page 592) / Montado (pág. 592) / Собранный (стр. 592)



Significativa variazione di aspetto superficiale, grafica e colore da piastrella a piastrella e all'interno della stessa piastrella. Si consiglia di visionare la gamma cromatica prima della selezione del materiale. / Significant variation in texture, pattern and colour from tile to tile within the same production run. The colour range should be viewed before selecting the material. / Bedeutende Variation in Aussehen, Struktur und Farbe von Fliese zu Fliese und in ein und derselben Fliese. Es wird empfohlen, das Farbsortiment vor der Auswahl des Materials zu prüfen. / Variation significative au niveau de l'aspect, de la fantaisie et de la couleur entre les carreaux et au sein d'un même carreau. Il est recommandé de consulter la gamme des couleurs avant de sélectionner le matériel. / Variación considerable en el aspecto superficial, los motivos y el color entre un azulejo y otro y dentro del propio azulejo. Es aconsejable visualizar la gama cromática antes de seleccionar el material. / Значительные отличия вида поверхности, графики и цвета у разных плиток и на одной и той же плитке. Перед отбором материала рекомендуется посмотреть цветовую гамму.

pezzi speciali / trims / spezialteile / pièces spéciales / piezas especiales / специальные изделия

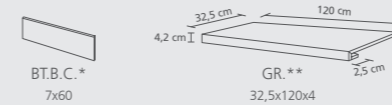

Woodtale Betulla	R4XU	R4XP
Woodtale Miele	R4XV	R4XQ
Woodtale Nociola	R4XW	R4XR
Woodtale Quercia	R4XX	R4XS
Woodtale Noce	R4XY	R4XT

imballi / packaging / verpackungen / emballages / embalajes / упаковки

Scatole / Box / Karton / Boîte / Caja / Коробки	Pallet / Pallet / Palette / Palette / Pallet / Поддон	mm
M <sup>2</sup>	M <sup>2</sup>	KG

fondi / plain tiles / grundfliesen / fonds / fondos / фоновая плитка						
30x120 rettificato	3	1,08	22,99	48	51,84	1103,52
20x120 rettificato	3	0,72	15,57	60	43,20	934,00
15x120 rettificato	6	1,08	22,68	40	43,20	907,00
pezzi speciali / trims / spezialteile / pièces spéciales / piezas especiales / специальные изделия						
7x60 BT.B.C.	14	8,40 ml	14,73			9,5
32,5x120x4 GR.	2	0,78	17,69			

# Woodmania

20x120



R56A Woodmania Honey 20x120

wood effect

# Woodmania

20x120



**R55Z** Woodmania Ivory  
**R56L** Woodmania Ivory Grip  
20x120



**R56A** Woodmania Honey  
**R56M** Woodmania Honey Grip  
20x120



**R56C** Woodmania Caramel  
**R56N** Woodmania Caramel Grip  
20x120



**R56D** Woodmania Musk  
**R56P** Woodmania Musk Grip  
20x120



**R56E** Woodmania Ash  
**R56Q** Woodmania Ash Grip  
20x120



Variations irrégulières de la couleur et de la texture d'une pièce à l'autre. L'aspect et la couleur peuvent être complètement différents d'un carreau à l'autre. Il est recommandé de consulter la gamme des couleurs avant de sélectionner le matériel.

Random differences from tile to tile. One tile may have totally different texture and colour from another. The colour range should be viewed before selecting the material.

Wesentliche Variationen von Fliese zu Fliese. Eine Fliese kann sich in Aussehen und Farbe komplett von einer anderen unterscheiden. Es wird empfohlen, das Farbsortiment vor der Auswahl des Materials zu prüfen.

Variations irrégulières entre les carreaux. L'aspect et la couleur peuvent être complètement différents d'un carreau à l'autre. Il est recommandé de consulter la gamme des couleurs avant de sélectionner le matériel.

Variaciones irregulares entre un azulejo y otro. Un azulejo puede ser completamente diferente de otro en el aspecto superficial y el color. Es aconsejable visualizar la gama cromática antes de seleccionar el material.

Неоднородные изменения на разных плитках. Каждая плитка может полностью отличаться по виду поверхности и цвету от другой. Перед отбором материала рекомендуется посмотреть цветовую гамму.

## tech info

\*

Battiscopa ottenuto da taglio del fondo / Skirting cut from plain tile / Aus Grundfliese geschnittener Sockel / Plinthe obtenue par découpe du fond / Rodapié obtenido mediante corte del fondo / Плинтус, полученный методом нарезания фоновой плитки

Per le pavimentazioni esterne non protette, Ragno consiglia di creare una pendenza  $\geq 1,5\%$  sulla superficie calpestabile allo scopo di limitare il formarsi di ristagni d'acqua localizzati. Nel caso in cui questi ristagni permangano sulla superficie delle piastrelle nonostante una posa a regola d'arte, è necessario intervenire meccanicamente con l'utilizzo di scope o aspira-liquidi. / For unprotected outdoor pavings, Ragno recommends the creation of a gradient of  $\geq 1.5\%$  on the finished surface, to prevent the formation of patches of standing water. In the event that standing water persists on the surface of the tiles in spite of correct installation, it must be removed mechanically with the aid of brooms or wet-and-dry vacuum cleaners. / Zur Unterbindung von punktueller Stauwasserbildung bei Belägen in ungeschützten Außenbereichen, empfiehlt die Ragno die Ausbildung eines Gefälles  $\geq 1,5\%$  auf der Trittfäche. Sollte trotz fachgerechter Verlegung Stauwasser auf der Fliesenoberfläche zurückbleiben, ist dessen mechanische Entfernung mit Hilfe eines Besens oder Nasssaugers erforderlich. / Pour des sols extérieurs non protégés, Ragno conseille de créer une inclinaison  $\geq 1,5\%$  sur la surface de piétinement en vue de limiter la stagnation localisée de l'eau. Si, malgré une pose dans les règles de l'art, cette stagnation devait persister à la surface des carreaux, une intervention mécanique, au moyen de balais et d'aspirateurs de liquides, est alors nécessaire. / En el caso de pavimentaciones exteriores no protegidas, Ragno recomienda crear una pendiente  $\geq 1,5\%$  en la superficie transitable para limitar la formación de depósitos localizados de agua estancada. En caso de que estos depósitos de agua permanezcan en la superficie del azulejo, aun cuando la colocación se haya realizado correctamente, será necesario intervenir mecánicamente empleando un cepillo o un aspirador de líquidos. / Для наружных незащищенных полов Ragno рекомендует создавать уклон  $\geq 1,5\%$  на пешеходной поверхности для снижения образования локальных застоев воды. В случае, если застои воды образуются на плитке несмотря на правильную укладку, необходимо прибегать к использованию механических средств, таких как щетки или же аппараты для сбора жидкостей.

\*\*

Assemblato (pag. 592) / Two-piece L-tile (page 592) / Randstein zweiteilig (S. 592) / Assemblé (page 592) / Montado (pág. 592) / Собранная (стр. 592)

## pezzi speciali / trims / spezialteile / pièces spéciales / piezas especiales / специальные изделия



BT.B.C.\*  
6x60

E.ELLE\*\*  
15x120x4

Woodmania Ivory	R56F	R14A
Woodmania Honey	R56G	R14C
Woodmania Caramel	R56H	R14D
Woodmania Musk	R56J	R14E
Woodmania Ash	R56K	R14F

**E.ELLE: solo su richiesta** / to order only / nur auf Anfrage / sur demande uniquement / solo bajo pedido / только по заказу

## imballi / packaging / verpackungen / emballages / embalajes / упаковки

Scatole / Box / Karton / Boîte / Caja / Коробки

Pallet / Pallet / Palette / Palette / Поддон

## fondi / plain tiles / grundfliesen / fonds / fondos / фоновая плитка

20x120	4	0,96	20,05	40	38,40	801,84	9,5
20x120 grip	4	0,96	20,05	40	38,40	801,84	9,5

## pezzi speciali / trims / spezialteile / pièces spéciales / piezas especiales / специальные изделия

6x60	BT.B.C.	14	8,4 ml	14,56			9,5
15x120x4	E.ELLE	2	0,36	17,00			

# Woodside

30x120 20x120 15x120



Gruppo Bia UNI EN 14411\_G

gres fine porcellanato colorato in massa - rettificato monocalibro / colorbody fine porcelain stoneware - rectified monocaliber / durchgefärbtes feinsteinzeug - rektifiziert, in einem werkmaß / grès cérame fin coloré dans la masse - rectifié monocalibre / gres porcelánico fino coloreado en toda la masa - rectificado monocalibre / гомогенный мелкозернистый керамогранит - ректифицированный монокалиберный

superfici / surfaces / finitions / oberflächen / superficies / поверхности: naturale/matt



R5PH Woodside Marrone rettificato 30x120



H



15x120

R5PQ Woodside Bianco rettificato



20x120

R5PK Woodside Bianco rettificato



30x120

R5PE Woodside Bianco rettificato



G

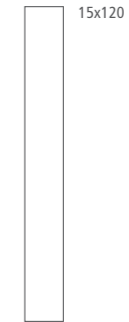

15x120

R5PR Woodside Naturale rettificato



20x120

R5PL Woodside Naturale rettificato



30x120

R5PF Woodside Naturale rettificato

wood effect

# Woodside

30x120 20x120 15x120

gres fine porcellanato colorato in massa - rettificato monocalibro / colorbody fine porcelain stoneware - rectified monocaliber / durchgefärbtes feinsteinzeug - rektifiziert, in einem werkmaß / grès cérame fin coloré dans la masse - rectifié monocalibre / gres porcelánico fino coloreado en toda la masa - rectificado monocalibre / гомогенный мелкозернистый керамогранит - ректифицированный монокалиберный

superfici / surfaces / finitions / oberflächen / superficies / поверхности:  
naturale/matt



H



15x120

R5PS Woodside Beige rettificato



20x120

R5PM Woodside Beige rettificato



30x120

R5PG Woodside Beige rettificato



G



15x120

R5PT Woodside Marrone rettificato



20x120

R5PN Woodside Marrone rettificato

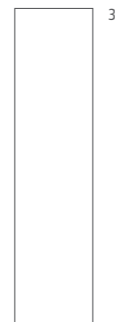

30x120

R5PH Woodside Marrone rettificato



G



15x120

R5PU Woodside Grigio rettificato



20x120

R5PP Woodside Grigio rettificato



30x120

R5PJ Woodside Grigio rettificato

## tech info

\*

Battiscopa ottenuto da taglio del fondo / Skirting cut from plain tile / Aus Grundfliese geschnittener Sockel / Plinthe obtenue par découpe du fond / Rodapié obtenido mediante corte del fondo / Плинтус, полученный методом нарезания фоновой плитки

\*\*

Assemblato (pag. 592) / Two-piece L-tile (page 592) / Randstein zweiteilig (S. 592) / Assemblé (page 592) / Montado (pág. 592) / Собранный (стр. 592)



Apprezzabili differenze nell'aspetto di superficie e grafica all'interno della stessa produzione. / Clearly distinguishable differences in texture and pattern within the same production run. / Auffällige Unterschiede in Aussehen und Struktur innerhalb der gleichen Produktionscharge. / Différences visibles au niveau de l'aspect et de la fantaisie entre les carreaux du même lot de production. / Diferencias visibles en el aspecto de la superficie y los motivos dentro de un mismo lote de producción. / Заметные отличия вида поверхности и графики в одной и той же партии.

pezzi speciali / trims / spezialteile / pièces spéciales / piezas especiales / специальные изделия



BT.B.C.\*  
7x60



GR.\*\*  
32,5x120x4,2

Woodside Bianco	R5Q1	R5PV
Woodside Naturale	R5Q2	R5PW
Woodside Beige	R5Q3	R5PX
Woodside Marrone	R5QA	R5PY
Woodside Grigio	R5QC	R5PZ

imballi / packaging / verpackungen / emballages / embalajes / упаковки

Scatole / Box / Karton / Boite / Caja / Коробки



M<sup>2</sup>

KG

Pallet / Pallet / Palette / Palette / Pallet / Поддон



M<sup>2</sup>

KG

≠ mm

fondi / plain tiles / grundfliesen / fonds / fondos / фоновая плитка								
30x120	rettificato	3	1,08	22,99	48	51,84	1103,52	9,5
20x120	rettificato	3	0,72	15,57	60	43,20	934,00	9,5
15x120	rettificato	6	1,08	22,68	40	43,20	907,00	9,5

pezzi speciali / trims / spezialteile / pièces spéciales / piezas especiales / специальные изделия								
7x60	BT.B.C.	14	8,40 ml	14,73				9,5
32,5x120x4	GR.	2	0,78	17,69				



# Woodsoft

20x120



R14K Woodsoft Belge Scuro rettificato 20x120

# Woodsoft

20x120

Gruppo Bia UNI EN 14411\_G

gres fine porcellanato colorato in massa - rettificato monocalibro / colorbody fine porcelain stoneware - rectified monocaliber / durchgefärbtes feinsteinzeug - rektifiziert, in einem werkmaß / grès cérame fin coloré dans la masse - rectifié monocalibre / gres porcelánico fino coloreado en toda la masa - rectificado monocalibre / гомогенный мелкозернистый керамогранит - ректифицированный монокалиберный



superfici / surfaces / finitions / oberflächen / superficies / поверхности: naturale/matt

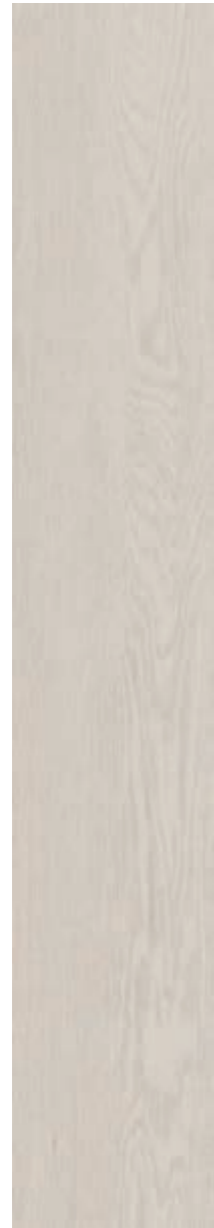

H

**R14H** Woodsoft Bianco rettificato 20x120



H

**R14J** Woodsoft Beige Ch. rettificato 20x120



H

**R14K** Woodsoft Beige Sc. rettificato 20x120



H

**R13Z** Woodsoft Tortora rettificato 20x120



H

**R141** Woodsoft Grigio rettificato 20x120

## tech info

\*

Battiscopa ottenuto da taglio del fondo / Skirting cut from plain tile / Aus Grundfliese geschnittener Sockel / Plinthe obtenue par découpe du fond / Rodapié obtenido mediante corte del fondo / Плинтус, полученный методом нарезания фоновой плитки



Apprezzabili differenze nell'aspetto di superficie e grafica all'interno della stessa produzione. / Clearly distinguishable differences in texture and pattern within the same production run. / Auffällige Unterschiede in Aussehen und Struktur innerhalb der gleichen Produktionscharge. / Différences visibles au niveau de l'aspect et de la fantaisie entre les carreaux du même lot de production. / Diferencias visibles en el aspecto de la superficie y los motivos dentro de un mismo lote de producción. / Заметные отличия вида поверхности и графики в одной и той же партии.

pezzi speciali / trims / spezialteile / pièces spéciales / piezas especiales / специальные изделия



BT.B.C.\*  
6x60

Woodsoft Bianco	R19J
Woodsoft Beige Ch.	R19K
Woodsoft Beige Sc.	R19L
Woodsoft Tortora	R19M
Woodsoft Grigio	R19N

imballi / packaging / verpackungen / emballages / embalajes / упаковки

Scatole / Box / Karton / Boite / Caja / Коробки Pallet / Pallet / Palette / Palette / Pallet / Поддон



fondi / plain tiles / grundfliesen / fonds / fondos / фоновая плитка	M²		KG		≠ mm		
20x120	4	0,96	24,00	40	38,40	960,00	9,5
pezzi speciali / trims / spezialteile / pièces spéciales / piezas especiales / специальные изделия	14	8,4 ml	12,50				9,5

# Woodplace

20x120



R499 Woodplace Sughero 20x120

wood effect

# Woodplace

20x120

Gruppo Bla UNI EN 14411\_G

gres fine porcellanato colorato in massa / colorbody fine porcelain stoneware / durchgefärbtes feinsteinzeug in einem werkmaß / grès cérame fin coloré dans la masse / gres porcelánico fino coloreado en toda la masa / гомогенный мелкозернистый керамогранит

superfici / surfaces / finitions / oberflächen / superficies / поверхности:  
naturale/matt



H

**R48Z** Woodplace Bianco Antico  
20x120



H

**R497** Woodplace Caramel  
20x120



H

**R498** Woodplace Cognac  
20x120



H

**R499** Woodplace Sughero  
20x120



H

**R49A** Woodplace Caffè  
20x120

wood effect

## tech info

\*

Battiscopa ottenuto da taglio del fondo  
Skirting cut from plain tile  
Aus Grundfliese geschnittener Sockel  
Plinthe obtenue par découpe du fond  
Rodapié obtenido mediante corte del fondo  
Плинтус, полученный методом нарезания фоновой плитки



Significativa variazione di aspetto superficiale, grafica e colore da piastrella a piastrella e all'interno della stessa piastrella. Si consiglia di visionare la gamma cromatica prima della selezione del materiale.  
/ Significant variation in texture, pattern and colour from tile to tile within the same production run. The colour range should be viewed before selecting the material. / Bedeutende Variation in Aussehen, Struktur und Farbe von Fliese zu Fliese und in ein und derselben Fliese. Es wird empfohlen, das Farbsortiment vor der Auswahl des Materials zu prüfen. / Variation significative au niveau de l'aspect, de la fantaisie et de la couleur entre les carreaux et au sein d'un même carreau. Il est recommandé de consulter la gamme des couleurs avant de sélectionner le matériel. / Variación considerable en el aspecto superficial, los motivos y el color entre un azulejo y otro y dentro del propio azulejo. Es aconsejable visualizar la gama cromática antes de seleccionar el material. / Значительные отличия вида поверхности, графики и цвета у разных плиток и на одной и той же плитке. Перед отбором материала рекомендуется посмотреть цветовую гамму.

## pezzi speciali / trims / spezialteile / pièces spéciales / piezas especiales / специальные изделия



BT.B.C.\*  
6x60

Woodplace Bianco Antico	R49C
Woodplace Caramel	R49D
Woodplace Cognac	R49E
Woodplace Sughero	R49F
Woodplace Caffè	R49G

## imballi / packaging / verpackungen / emballages / embalajes / упаковки

Scatole / Box / Karton / Boite / Caja / Коробки

Pallet / Pallet / Palette / Palette / Pallet / Поддон

	M <sup>2</sup>	KG	M <sup>2</sup>	KG	# mm		
<b>fondi</b> / plain tiles / grundfliesen / fonds / fondos / фоновая плитка							
20x120	4	0,96	19,72	40	38,40	788,80	9
<b>pezzi speciali</b> / trims / spezialteile / pièces spéciales / piezas especiales / специальные изделия							
6x60	BT.B.C.	14	8,40 ml	14,56			9

# Woodspirit

20x120



R4LH Woodspirit Beige 20x120

wood effect

# Woodspirit

20x120

Gruppo Bla UNI EN 14411\_G

gres fine porcellanato colorato in massa / colorbody fine porcelain stoneware / durchgefärbtes feinsteinzeug / grès cérame fin coloré dans la masse / gres porcelánico fino coloreado en toda la masa / гомогенный мелкозернистый керамогранит

superfici / surfaces / finitions / oberflächen / superficies / поверхности:  
naturale/matt + outdoor



G

R4KW Woodspirit White  
20x120



H

R4LL Woodspirit Grey  
R4LV Woodspirit Grey Grip  
20x120



H

R4LH Woodspirit Beige  
R4LT Woodspirit Beige Grip  
20x120



H

R4LJ Woodspirit Brown  
R4LU Woodspirit Brown Grip  
20x120



H

R4LK Woodspirit Cherry  
20x120



wood effect

Per le pavimentazioni esterne non protette, Ragno consiglia di creare una pendenza  $\geq 1,5\%$  sulla superficie calpestabile allo scopo di limitare il formarsi di ristagni d'acqua localizzati. Nel caso in cui questi ristagni permangano sulla superficie delle piastrelle nonostante una posa a regola d'arte, è necessario intervenire meccanicamente con l'utilizzo di scope o aspira-liquidi. / For unprotected outdoor pavings, Ragno recommends the creation of a gradient of  $\geq 1.5\%$  on the finished surface, to prevent the formation of patches of standing water. In the event that standing water persists on the surface of the tiles in spite of correct installation, it must be removed mechanically with the aid of brooms or wet-and-dry vacuum cleaners. / Zur Unterbindung von punktueller Stauwasserbildung bei Belägen in ungeschützten Außenbereichen, empfiehlt die Ragno die Ausbildung eines Gefälles  $\geq 1,5\%$  auf der Trittläche. Sollte trotz fachgerechter Verlegung Stauwasser auf der Fliesenoberfläche zurückbleiben, ist dessen mechanische Entfernung mit Hilfe eines Besens oder Nasssaugers erforderlich. / Pour des sols extérieurs non protégés, Ragno conseille de créer une inclinaison  $\geq 1,5\%$  sur la surface de piétinement en vue de limiter la stagnation localisée de l'eau. Si, malgré une pose dans les règles de l'art, cette stagnation devait persister à la surface des carreaux, une intervention mécanique, au moyen de balais et d'aspirateurs de liquides, est alors nécessaire. / En el caso de pavimentaciones exteriores no protegidas, Ragno recomienda crear una pendiente  $\geq 1,5\%$  en la superficie transitable para limitar la formación de depósitos localizados de agua estancada. En caso de que estos depósitos de agua permanezcan en la superficie del azulejo, aun cuando la colocación se haya realizado correctamente, será necesario intervenir mecánicamente empleando un cepillo o un aspirador de líquidos. / Для наружных незащищенных полов Ragno рекомендует создавать уклон  $\geq 1,5\%$  на пешеходной поверхности для снижения образования локальных застоев воды. В случае, если застои воды образуются на плитке несмотря на правильную укладку, необходимо прибегать к использованию механических средств, таких как щетки или же аппараты для сбора жидкостей.

## tech info

\*

Battiscopa ottenuto da taglio del fondo  
Skirting cut from plain tile  
Aus Grundfliese geschnittener Sockel  
Plinthe obtenue par découpe du fond  
Rodapié obtenido mediante corte del fondo  
Плинтус, полученный методом нарезания фоновой плитки



Variazioni irregolari da piastrella a piastrella. Una piastrella può differire totalmente nell'aspetto superficiale e colore da un'altra. Si consiglia di visionare la gamma cromatica prima della selezione del materiale. / Random differences from tile to tile. One tile may have totally different texture and colour from another. The colour range should be viewed before selecting the material. / Wesentliche Variationen von Fliese zu Fliese. Eine Fliese kann sich in Aussehen und Farbe komplett von einer anderen unterscheiden. Es wird empfohlen, das Farbsortiment vor der Auswahl des Materials zu prüfen. / Variations irrégulières entre les carreaux. L'aspect et la couleur peuvent être complètement différents d'un carreau à l'autre. Il est recommandé de consulter la gamme des couleurs avant de sélectionner le matériel. / Variaciones irregulares entre un azulejo y otro. Un azulejo puede ser completamente diferente de otro en el aspecto superficial y el color. Es aconsejable visualizar la gama cromática antes de seleccionar el material. / Неоднородные изменения на разных плитках. Каждая плитка может полностью отличаться по виду поверхности и цвету от другой. Перед отбором материала рекомендуется просмотреть цветовую гамму.

pezzi speciali / trims / spezialteile / pièces spéciales / piezas especiales / специальные изделия



BT.B.C.\*  
6x60

Woodspirit White	R4MP
Woodspirit Grey	R4MT
Woodspirit Beige	R4MQ
Woodspirit Brown	R4MR
Woodspirit Cherry	R4MS

imballi / packaging / verpackungen / emballages / embalajes / упаковки

Scatole / Box / Karton / Boite / Caja / Коробки

Pallet / Pallet / Palette / Palette / Поддон

	M <sup>2</sup>	KG		M <sup>2</sup>	KG	≠ mm
--	----------------	----	--	----------------	----	------

fondi / plain tiles / grundfliesen / fonds / fondos / фоновая плитка						
20x120		4	0,96	19,72	40	38,40 788,80 9
20x120	grip	4	0,96	19,72	40	38,40 788,80 9
pezzi speciali / trims / spezialteile / pièces spéciales / piezas especiales / специальные изделия						
6x60	BT.B.C.	14	8,40 ml	14,56		9

# Woodclassic

10x100 13x100



R5RW Woodclassic Beige 10x100 / 13x100

wood effect

# Woodclassic

10x100 13x100

Gruppo Bia UNI EN 14411\_G

gres porcellanato / porcelain stoneware / feinsteinzeug / grès cérame émaillé / gres porcelánico / керамогранит

superfici / surfaces / finitions / oberflächen / superficies / поверхности:  
naturale/matt



RSRV Woodclassic Bianco

H

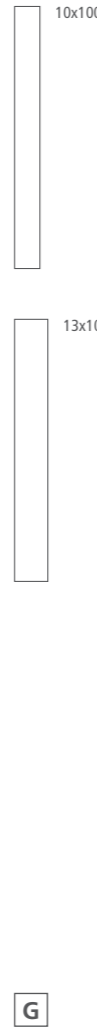

RSRW Woodclassic Beige

G



RSRX Woodclassic Marrone

H



RSRY Woodclassic Tortora

G

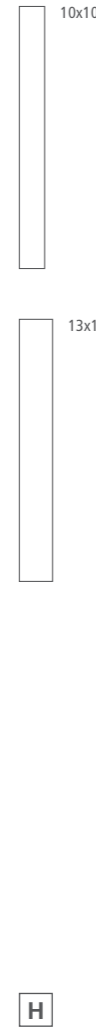

RSRZ Woodclassic Grigio

H

## tech info

\*

Battiscopa ottenuto da taglio del fondo / Skirting cut from plain tile / Aus Grundfliese geschnittener Sockel / Plinthe obtenue par découpe du fond / Rodapié obtenido mediante corte del fondo / Плинтус, полученный методом нарезания фоновой плитки



Apprezzabili differenze nell'aspetto di superficie e grafica all'interno della stessa produzione. / Clearly distinguishable differences in texture and pattern within the same production run. / Auffällige Unterschiede in Aussehen und Struktur innerhalb der gleichen Produktionscharge. / Différences visibles au niveau de l'aspect et de la fantaisie entre les carreaux du même lot de production. / Diferencias visibles en el aspecto de la superficie y los motivos dentro de un mismo lote de producción. / Заметные отличия вида поверхности и графики в одной и той же партии.

Ogni scatola contiene 5 pz del formato 10x100 e 5 pz del formato 13x100 da posare insieme. / Each box contains 5 pcs of the 10x100 cm and 5 pcs of the 13x100 cm sizes, for installation together. / Jeder Karton enthält 5 Stück im Format 10x100 cm und 5 Stück im Format 13x100 cm, die im Mix verlegt werden. / Chaque boîte contient 5 pièces au format 10x100 cm et 5 pièces au format 13x100 cm à poser ensemble. / Cada una de las cajas contiene cinco piezas de 10 x 100 cm y otras cinco de 13 x 100 cm que colocar combinadas. / Каждая коробка содержит в себе 5 изделий в формате 10x100 см и 5 изделий в формате 13x100 см, предназначенных для совместной укладки.

pezzi speciali / trims / spezialteile / pièces spéciales / piezas especiales / специальные изделия



BT.B.C.\*  
5x100

Woodclassic Bianco	RSYA
Woodclassic Beige	RSYD
Woodclassic Marrone	RSYE
Woodclassic Tortora	RSYF
Woodclassic Grigio	RSYG

imballi / packaging / verpackungen / emballages / embalajes / упаковки

Scatole / Box / Karton / Boite / Caja / Коробки

Pallet / Pallet / Palette / Palette / Pallet / Поддон



fondi / plain tiles / grundfliesen / fonds / fondos / фоновая плитка						
Formato	Scatole	M²	KG	Pallet	M²	KG
10x100 / 13x100	10	1,15	24,50	60	69,00	1470,00
pezzi speciali / trims / spezialteile / pièces spéciales / piezas especiales / специальные изделия						
5x100	BT.B.C.	10	10 ml	12,29		9,0



# Woodreal

10x100 13x100



R558 Woodreal Bianco 10x100 / 13x100

wood effect

# Woodreal

10x100 13x100

Gruppo Bia UNI EN 14411\_G

gres porcellanato / porcelain stoneware / feinsteinzeug / grès cérame émaillé / gres porcelánico / керамогранит

superfici / surfaces / finitions / oberflächen / superficies / поверхности:  
naturale/matt



R558 Woodreal Bianco

G



R559 Woodreal Beige

H



R55A Woodreal Caramello

G



R55C Woodreal Marrone

G



R55D Woodreal Tortora

H

## tech info

\*

Battiscopa ottenuto da taglio del fondo / Skirting cut from plain tile / Aus Grundfliese geschnittener Sockel / Plinthe obtenue par découpe du fond / Rodapié obtenido mediante corte del fondo / Плинтус, полученный методом нарезания фоновой плитки



Apprezzabili differenze nell'aspetto di superficie e grafica all'interno della stessa produzione. / Clearly distinguishable differences in texture and pattern within the same production run. / Auffällige Unterschiede in Aussehen und Struktur innerhalb der gleichen Produktionscharge. / Différences visibles au niveau de l'aspect et de la fantaisie entre les carreaux du même lot de production. / Diferencias visibles en el aspecto de la superficie y los motivos dentro de un mismo lote de producción. / Заметные отличия вида поверхности и графики в одной и той же партии.

Ogni scatola contiene 5 pz del formato 10x100 e 5 pz del formato 13x100 da posare insieme. / Each box contains 5 pcs of the 10x100 cm and 5 pcs of the 13x100 cm sizes, for installation together. / Jeder Karton enthält 5 Stück im Format 10x100 cm und 5 Stück im Format 13x100 cm, die im Mix verlegt werden. / Chaque boîte contient 5 pièces au format 10x100 cm et 5 pièces au format 13x100 cm à poser ensemble. / Cada una de las cajas contiene cinco piezas de 10 x 100 cm y otras cinco de 13 x 100 cm que colocar combinadas. / Каждая коробка содержит в себе 5 изделий в формате 10x100 см и 5 изделий в формате 13x100 см, предназначенных для совместной укладки.

pezzi speciali / trims / spezialteile / pièces spéciales / piezas especiales / специальные изделия



BT.B.C.\*  
5x100

Woodreal Bianco	RSYH
Woodreal Beige	RSYJ
Woodreal Caramello	RSYK
Woodreal Marrone	RSYM
Woodreal Tortora	RSYN

imballi / packaging / verpackungen / emballages / embalajes / упаковки

Scatole / Box / Karton / Boite / Caja / Коробки Pallet / Pallet / Palette / Palette / Pallet / Поддон



fondi / plain tiles / grundfliesen / fonds / fondos / фоновая плитка						
10x100 / 13x100	10	1,15	24,50	60	69,00	1470,00
<b>pezzi speciali / trims / spezialteile / pièces spéciales / piezas especiales / специальные изделия</b>						
5x100	BT.B.C.	10	10 ml	12,29		9,0

# Woodshape

15x90



R5RG Woodshape Grigio 15x90

wood effect

# Woodshape

15x90

Gruppo Bia UNI EN 14411\_G

gres porcellanato / porcelain stoneware / feinsteinzeug / grès cérame émaillé / gres porcelánico / керамогранит

superfici / surfaces / finitions / oberflächen / superficies / поверхности:  
naturale/matt + outdoor

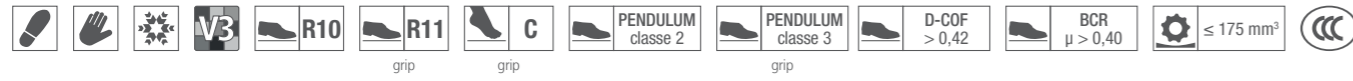

**RSRD** Woodshape Bianco  
15x90



**RSRE** Woodshape Beige  
15x90



**RSRF** Woodshape Marrone  
15x90



**RSRG** Woodshape Grigio  
15x90



**RSRH** Woodshape Beige Grip  
15x90



**RSRJ** Woodshape Marrone Grip  
15x90



**RSRK** Woodshape Grigio Grip  
15x90

## tech info

★

Battiscopa ottenuto da taglio del fondo / Skirting cut from plain tile / Aus Grundfliese geschnittener Sockel / Plinthe obtenue par découpe du fond / Rodapié obtenido mediante corte del fondo / Плинтус, полученный методом нарезания фоновой плитки



Significativa variazione di aspetto superficiale, grafica e colore da piastrella a piastrella e all'interno della stessa piastrella. Si consiglia di visionare la gamma cromatica prima della selezione del materiale. / Significant variation in texture, pattern and colour from tile to tile within the same production run. The colour range should be viewed before selecting the material. / Bedeutende Variation in Aussehen, Struktur und Farbe von Fliese zu Fliese und in ein und derselben Fliese. Es wird empfohlen, das Farbsortiment vor der Auswahl des Materials zu prüfen. / Variation significative au niveau de l'aspect, de la fantaisie et de la couleur entre les carreaux et au sein d'un même carreau. Il est recommandé de consulter la gamme des couleurs avant de sélectionner le matériel. / Variación considerable en el aspecto superficial, los motivos y el color entre un azulejo y otro y dentro del propio azulejo. Es aconsejable visualizar la gama cromática antes de seleccionar el material. / Значительные отличия вида поверхности, графики и цвета у разных плиток и на одной и той же плитке. Перед отбором материала рекомендуется посмотреть цветовую гамму.

pezzi speciali / trims / spezialteile / pièces spéciales / piezas especiales / специальные изделия



BT.B.C.\*  
7,5x90

Woodshape Bianco	RSRL
Woodshape Beige	RSRM
Woodshape Marrone	RSRN
Woodshape Grigio	RSRP

imballi / packaging / verpackungen / emballages / embalajes / упаковки

Scatole / Box / Karton / Boite / Caja / Коробки		Pallet / Pallet / Palette / Palette / Pallet / Поддон				
	M <sup>2</sup>	KG		M <sup>2</sup>	KG	≠ mm

fondi / plain tiles / grundfliesen / fonds / fondos / фоновая плитка								
15x90		8	1,08	19,35	48	51,84	928,80	8
15x90	grip	8	1,08	19,35	48	51,84	928,80	8
pezzi speciali / trims / spezialteile / pièces spéciales / piezas especiales / специальные изделия								
7,5x90	BT.B.C.	15	13,50 ml	20,00				8

# Woodstory

15x90



R5QV Woodstory Grigio 15x90

wood effect

# Woodstory

15x90



G

**R5QR** Woodstory Bianco  
15x90



G

**R5QS** Woodstory Beige  
15x90

**R5RQ** Woodstory Beige Grip  
15x90



G

**R5QT** Woodstory Marrone  
15x90

**R5RR** Woodstory Marrone Grip  
15x90



G

**R5QU** Woodstory Tortora  
15x90



G

**R5QV** Woodstory Grigio  
15x90

**R5RS** Woodstory Grigio Grip  
15x90

## tech info

\*

Battiscopa ottenuto da taglio del fondo / Skirting cut from plain tile / Aus Grundfliese geschmittener Sockel / Plinthe obtenue par découpe du fond / Rodapié obtenido mediante corte del fondo / Плинтус, полученный методом нарезания фоновой плитки



Significativa variazione di aspetto superficiale, grafica e colore da piastrella a piastrella e all'interno della stessa piastrella. Si consiglia di visionare la gamma cromatica prima della selezione del materiale. / Significant variation in texture, pattern and colour from tile to tile within the same production run. The colour range should be viewed before selecting the material. / Bedeutende Variation in Aussehen, Struktur und Farbe von Fliese zu Fliese und in ein und derselben Fliese. Es wird empfohlen, das Farbsortiment vor der Auswahl des Materials zu prüfen. / Variation significative au niveau de l'aspect, de la fantaisie et de la couleur entre les carreaux et au sein d'un même carreau. Il est recommandé de consulter la gamme des couleurs avant de sélectionner le matériel. / Variación considerable en el aspecto superficial, los motivos y el color entre un azulejo y otro y dentro del propio azulejo. Es aconsejable visualizar la gama cromática antes de seleccionar el material. / Значительные отличия вида поверхности, графики и цвета у разных плиток и на одной и той же плитке. Перед отбором материала рекомендуется посмотреть цветовую гамму.

## pezzi speciali / trims / spezialteile / pièces spéciales / piezas especiales / специальные изделия



BT.B.C.\*  
7,5x90

Woodstory Bianco	R5QW
Woodstory Beige	R5QX
Woodstory Marrone	R5QZ
Woodstory Tortora	R5RA
Woodstory Grigio	R5RC

## imballi / packaging / verpackungen / emballages / embalajes / упаковки

Scatole / Box / Karton / Boite / Caja / Коробки Pallet / Pallet / Palette / Palette / Pallet / Поддон

	<b>M<sup>2</sup></b>	<b>KG</b>		<b>M<sup>2</sup></b>	<b>KG</b>	<b>≠</b>	<b>mm</b>
--	----------------------	-----------	--	----------------------	-----------	----------	-----------

fondi / plain tiles / grundfliesen / fonds / fondos / фоновая плитка								
15x90		8	1,08	19,35	48	51,84	928,80	8
15x90	grip	8	1,08	19,35	48	51,84	928,80	8
pezzi speciali / trims / spezialteile / pièces spéciales / piezas especiales / специальные изделия								
7,5x90	BT.B.C.	15	13,50 ml	20,00				8

# Woodchalet

15x90



RGEU Woodchalet Beige 15x90

wood effect

# Woodchalet

15x90

Gruppo Bia UNI EN 14411\_G

gres porcellanato / porcelain stoneware / feinsteinzeug / grès cérame émaillé / gres porcelánico / керамогранит

superfici / surfaces / finitions / oberflächen / superficies / поверхности:  
naturale/matt

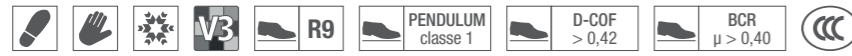

G

RGEU Woodchalet Beige  
15x90



G

RGEV Woodchalet Gold  
15x90



G

RGEW Woodchalet Cherry  
15x90



G

RGEX Woodchalet Brown  
15x90



G

RGEY Woodchalet Grey  
15x90

## tech info

\*

Battiscopa ottenuto da taglio del fondo / Skirting cut from plain tile / Aus Grundfliese geschnittener Sockel / Plinthe obtenue par découpe du fond / Rodapié obtenido mediante corte del fondo / Плинтус, полученный методом нарезания фоновой плитки



Significativa variazione di aspetto superficiale, grafica e colore da piastrella a piastrella e all'interno della stessa piastrella. Si consiglia di visionare la gamma cromatica prima della selezione del materiale. / Significant variation in texture, pattern and colour from tile to tile within the same production run. The colour range should be viewed before selecting the material. / Bedeutende Variation in Aussehen, Struktur und Farbe von Fliese zu Fliese und in ein und derselben Fliese. Es wird empfohlen, das Farbsortiment vor der Auswahl des Materials zu prüfen. / Variation significative au niveau de l'aspect, de la fantaisie et de la couleur entre les carreaux et au sein d'un même carreau. Il est recommandé de consulter la gamme des couleurs avant de sélectionner le matériel. / Variación considerable en el aspecto superficial, los motivos y el color entre un azulejo y otro y dentro del propio azulejo. Es aconsejable visualizar la gama cromática antes de seleccionar el material. / Значительные отличия вида поверхности, графики и цвета у разных плиток и на одной и той же плитке. Перед отбором материала рекомендуется посмотреть цветовую гамму.

pezzi speciali / trims / spezialteile / pièces spéciales / piezas especiales / специальные изделия



BT.B.C.\*  
7,5x90

Woodchalet Beige	RGEZ
Woodchalet Gold	RGFO
Woodchalet Cherry	RGF1
Woodchalet Brown	RGF2
Woodchalet Grey	RGF3

imballi / packaging / verpackungen / emballages / embalajes / упаковки

Scatole / Box / Karton / Boite / Caja / Коробки		Pallet / Pallet / Palette / Palette / Pallet / Поддон				
	M <sup>2</sup>	KG		M <sup>2</sup>	KG	mm

fondi / plain tiles / grundfliesen / fonds / fondos / фоновая плитка							
15x90	8	1,08	19,35	48	51,84	928,80	8
pezzi speciali / trims / spezialteile / pièces spéciales / piezas especiales / специальные изделия							
7,5x90	15	13,5 ml	24,10				8



# Harmony

15x90



R2XN Harmony Grip Marrone 15x90  
R2KK Harmony Marrone 15x90

wood effect

# Harmony

15x90

Gruppo Bia UNI EN 14411\_G

gres porcellanato / porcelain stoneware / feinsteinzeug / grès cérame émaillé / gres porcelánico / керамогранит

superfici / surfaces / finitions / oberflächen / superficies / поверхности:  
naturale/matt + outdoor



H

R2KF Harmony Bianco  
15x90



G

R2KG Harmony Tortora  
15x90



H

R2KJ Harmony Miele  
15x90



G

R2KH Harmony Beige  
15x90



G

R2KK Harmony Marrone  
15x90



H

R2XJ Harmony Grip Bianco  
15x90



G

R2XL Harmony Grip Tortora  
15x90



H

R2XM Harmony Grip Miele  
15x90



G

R2XK Harmony Grip Beige  
15x90



G

R2XN Harmony Grip Marrone  
15x90

wood effect

## tech info

\*

Battiscopa ottenuto da taglio del fondo / Skirting cut from plain tile / Aus Grundfliese geschnittener Sockel / Plinthe obtenue par découpe du fond / Rodapié obtenido mediante corte del fondo / Плинтус, полученный методом нарезания фоновой плитки

Per le pavimentazioni esterne non protette, Ragno consiglia di creare una pendenza  $\geq 1,5\%$  sulla superficie calpestabile allo scopo di limitare il formarsi di ristagni d'acqua localizzati. Nel caso in cui questi ristagni permangano sulla superficie delle piastrelle nonostante una posa a regola d'arte, è necessario intervenire meccanicamente con l'utilizzo di scope o aspira-liquidi. / For unprotected outdoor pavings, Ragno recommends the creation of a gradient of  $\geq 1,5\%$  on the finished surface, to prevent the formation of patches of standing water. In the event that standing water persists on the surface of the tiles in spite of correct installation, it must be removed mechanically with the aid of brooms or wet-and-dry vacuum cleaners. / Zur Unterbindung von punktueller Stauwasserbildung bei Belägen in ungeschützten Außenbereichen, empfiehlt die Ragno die Ausbildung eines Gefälles  $\geq 1,5\%$  auf der Trittlfläche. Sollte trotz fachgerechter Verlegung Stauwasser auf der Fliesenoberfläche zurückbleiben, ist dessen mechanische Entfernung mit Hilfe eines Besens oder Nasssaugers erforderlich. / Pour des sols extérieurs non protégés, Ragno conseille de créer une inclinaison  $\geq 1,5\%$  sur la surface de piétinement en vue de limiter la stagnation localisée de l'eau. Si, malgré une pose dans les règles de l'art, cette stagnation devait persister à la surface des carreaux, une intervention mécanique, au moyen de balais et d'aspirateurs de liquides, est alors nécessaire. / En el caso de pavimentaciones exteriores no protegidas, Ragno recomienda crear una pendiente  $\geq 1,5\%$  en la superficie transitabile para limitar la formación de depósitos localizados de agua estancada. En caso de que estos depósitos de agua permanezcan en la superficie del azulejo, aun cuando la colocación se haya realizado correctamente, será necesario intervenir mecánicamente empleando un cepillo o un aspirador de líquidos. / Для наружных незащищенных полов Ragno рекомендует создавать уклон  $\geq 1,5\%$  на пешеходной поверхности для снижения образования локальных застоев воды. В случае, если застои воды образуются на плитке несмотря на правильную укладку, необходимо прибегать к использованию механических средств, таких как щетки или же аппараты для сбора жидкостей.

## pezzi speciali / trims / spezialteile / pièces spéciales / piezas especiales / специальные изделия



BT.B.C.\*  
7,5x90

Harmony Bianco	R2XP
Harmony Miele	R2XQ
Harmony Beige	R2XR
Harmony Tortora	R2XS
Harmony Marrone	R2XT

## imballi / packaging / verpackungen / emballages / embalajes / упаковки

Scatole / Box / Karton / Boite / Caja / Коробки



M<sup>2</sup>

KG

Pallet / Pallet / Palette / Palette / Pallet / Поддон



M<sup>2</sup>

KG

mm

fondi / plain tiles / grundfliesen / fonds / fondos / фоновая плитка								
15x90		8	1,08	19,35	48	51,84	928,80	8
15x90	grip	8	1,08	19,35	48	51,84	928,80	8
pezzi speciali / trims / spezialteile / pièces spéciales / piezas especiales / специальные изделия								
7,5x90	BT.B.C.	15	13,5 ml	24,10				8

# Woodcomfort

15x90



R3TV Woodcomfort Acero 15x90  
R3PF Stoneway\_Barge Beige rettificato 60x60

wood effect

# Woodcomfort

15x90

Gruppo Bia UNI EN 14411\_G

gres porcellanato / porcelain stoneware / feinsteinzeug / grès cérame émaillé / gres porcelánico / керамогранит

superfici / surfaces / finitions / oberflächen / superficies / поверхности:  
naturale/matt



G

R3TT Woodcomfort Faggio  
15x90



G

R3TU Woodcomfort Ulivo  
15x90



G

R3TV Woodcomfort Acero  
15x90



G

R3TW Woodcomfort Noce  
15x90



V3



wood effect

## tech info

\*

Battiscopa ottenuto da taglio del fondo  
Skirting cut from plain tile  
Aus Grundfliese geschnittener Sockel  
Plinthe obtenue par découpe du fond  
Rodapié obtenido mediante corte del fondo  
Плинтус, полученный методом нарезания фоновой плитки

V3

Significativa variazione di aspetto superficiale, grafica e colore da piastrella a piastrella e all'interno della stessa piastrella. Si consiglia di visionare la gamma cromatica prima della selezione del materiale. / Significant variation in texture, pattern and colour from tile to tile within the same production run. The colour range should be viewed before selecting the material. / Bedeutende Variation in Aussehen, Struktur und Farbe von Fliese zu Fliese und in ein und derselben Fliese. Es wird empfohlen, das Farbsortiment vor der Auswahl des Materials zu prüfen. / Variation significative au niveau de l'aspect, de la fantaisie et de la couleur entre les carreaux et au sein d'un même carreau. Il est recommandé de consulter la gamme des couleurs avant de sélectionner le matériel. / Variación considerable en el aspecto superficial, los motivos y el color entre un azulejo y otro y dentro del propio azulejo. Es aconsejable visualizar la gama cromática antes de seleccionar el material. / Значительные отличия вида поверхности, графики и цвета у разных плиток и на одной и той же плитке. Перед отбором материала рекомендуется просмотреть цветовую гамму.

pezzi speciali / trims / spezialteile / pièces spéciales / piezas especiales / специальные изделия



BT.B.C.\*  
7,5x90

Woodcomfort Faggio	R3TX
Woodcomfort Ulivo	R3TY
Woodcomfort Acero	R3TZ
Woodcomfort Noce	R3UA

imballi / packaging / verpackungen / emballages / embalajes / упаковки

Scatole / Box / Karton / Boite / Caja / Коробки

Pallet / Pallet / Palette / Palette / Pallet / Поддон

M<sup>2</sup> KG M<sup>2</sup> KG mm

fondi / plain tiles / grundfliesen / fonds / fondos / фоновая плитка						
15x90	8	1,08	19,35	48	51,84	928,80
pezzi speciali / trims / spezialteile / pièces spéciales / piezas especiales / специальные изделия						
7,5x90	BT.B.C.	15	13,50 ml	24,10		8

# Woodlike

15x90

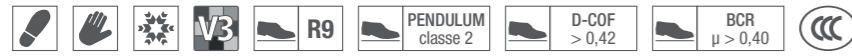

Gruppo Bla UNI EN 14411\_G

gres porcellanato / porcelain stoneware / feinsteinzeug / grès cérame émaillé / gres porcelánico / керамогранит

superfici / surfaces / finitions / oberflächen / superficies / поверхности:  
naturale/matt



R4WF Woodlike Grey 15x90



H

R4WC Woodlike Gold  
15x90



H

R4WD Woodlike Beige  
15x90



H

R4WE Woodlike Walnut  
15x90



G

R4WF Woodlike Grey  
15x90

wood effect

## tech info

\*

Battiscopa ottenuto da taglio del fondo  
Skirting cut from plain tile  
Aus Grundfliese geschnittener Sockel  
Plinthe obtenue par découpe du fond  
Rodapié obtenido mediante corte del fondo  
Плинтус, полученный методом нарезания фоновой плитки



Significativa variazione di aspetto superficiale, grafica e colore da piastrella a piastrella e all'interno della stessa piastrella. Si consiglia di visionare la gamma cromatica prima della selezione del materiale. / Significant variation in texture, pattern and colour from tile to tile within the same production run. The colour range should be viewed before selecting the material. / Bedeutende Variation in Aussehen, Struktur und Farbe von Fliese zu Fliese und in ein und derselben Fliese. Es wird empfohlen, das Farbsortiment vor der Auswahl des Materials zu prüfen. / Variation significative au niveau de l'aspect, de la fantaisie et de la couleur entre les carreaux et au sein d'un même carreau. Il est recommandé de consulter la gamme de couleurs avant de sélectionner le matériel. / Variación considerable en el aspecto superficial, los motivos y el color entre un azulejo y otro y dentro del propio azulejo. Es aconsejable visualizar la gama cromática antes de seleccionar el material. / Значительные отличия вида поверхности, графики и цвета у разных плиток и на одной и той же плитке. Перед отбором материала рекомендуется просмотреть цветовую гамму.

pezzi speciali / trims / spezialteile / pièces spéciales / piezas especiales / специальные изделия



BT.B.C.\*  
7,5x90

Woodlike Gold	R4WG
Woodlike Beige	R4WH
Woodlike Walnut	R4WJ
Woodlike Grey	R4WK

imballi / packaging / verpackungen / emballages / embalajes / упаковки

Scatole / Box / Karton /  
Boite / Caja / Коробки

Pallet / Pallet / Palette /  
Palette / Pallet / Поддон



fondi / plain tiles / grundfliesen / fonds / fondos / фоновая плитка						
15x90	8	1,08	19,35	48	51,84	928,80
pezzi speciali / trims / spezialteile / pièces spéciales / piezas especiales / специальные изделия						
7,5x90	BT.B.C.	15	13,50 ml	24,10		8

# Woodclass

14,5x90



R76U Woodclass White rettificato 14,5x90

# Woodclass

14,5x90

Gruppo Bia UNI EN 14411\_G

gres porcellanato - rettificato monoclibro / porcelain stoneware - rectified monocliber / feinsteinzeug - rektifiziert, in einem werkmaß / grès cérame émaillé - rectifié monoclibre / gres porcelánico - rectificado monoclibre / керамогранит - ректифицированный монокалиберный

superfici / surfaces / finitions / oberflächen / superficies / поверхности:  
naturale/matt



H

R76U Woodclass White rettificato  
14,5x90



H

R76V Woodclass Beige rettificato  
14,5x90



H

R76R Woodclass Honey rettificato  
14,5x90



H

R76S Woodclass Cherry rettificato  
14,5x90



H

R76T Woodclass Walnut rettificato  
14,5x90

wood effect

## tech info

\*  
Battiscopa ottenuto da taglio del fondo / Skirting cut from plain tile / Aus Grundfliese geschnittener Sockel / Plinthe obtenue par découpe du fond / Rodapié obtenido mediante corte del fondo / Плинтус, полученный методом нарезания фоновой плитки



Significativa variazione di aspetto superficiale, grafica e colore da piastrella a piastrella e all'interno della stessa piastrella. Si consiglia di visionare la gamma cromatica prima della selezione del materiale. / Significant variation in texture, pattern and colour from tile to tile within the same production run. The colour range should be viewed before selecting the material. / Bedeutende Variation in Aussehen, Struktur und Farbe von Fliese zu Fliese und in ein und derselben Fliese. Es wird empfohlen, das Farbsortiment vor der Auswahl des Materials zu prüfen. / Variation significative au niveau de l'aspect, de la fantaisie et de la couleur entre les carreaux et au sein d'un même carreau. Il est recommandé de consulter la gamme des couleurs avant de sélectionner le matériel. / Variación considerable en el aspecto superficial, los motivos y el color entre un azulejo y otro y dentro del propio azulejo. Es aconsejable visualizar la gama cromática antes de seleccionar el material. / Значительные отличия вида поверхности, графики и цвета у разных плиток и на одной и той же плитке. Перед отбором материала рекомендуется посмотреть цветовую гамму.

## pezzi speciali / trims / spezialteile / pièces spéciales / piezas especiales / специальные изделия

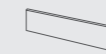

BT.B.C.  
7,2x90

Woodclass White	R77C
Woodclass Beige	R77D
Woodclass Honey	R76Y
Woodclass Cherry	R76Z
Woodclass Walnut	R77A

## imballi / packaging / verpackungen / emballages / embalajes / упаковки

Scatole / Box / Karton / Boite / Caja / Коробки  
Pallet / Pallet / Palette / Palette / Palette / Поддон



fondi / plain tiles / grundfliesen / fonds / fondos / фоновая плитка								
14,5x90	rettificato	8	1,04	18,96	48	50,11	910,00	8
<b>pezzi speciali / trims / spezialteile / pièces spéciales / piezas especiales / специальные изделия</b>								
7,2x90	BT.B.C.	15	13,50 ml	17,64				8

# Woodpassion

14,5x90 15x90



R44Q Woodpassion Smoke 15x90

wood effect



# Woodpassion

14,5x90 15x90

Gruppo Bla UNI EN 14411\_G

gres porcellanato / porcelain stoneware / feinsteinzeug / grès cérame émaillé / gres porcelánico / керамогранит

superfici / surfaces / finitions / oberflächen / superficies / поверхности:  
naturale/matt



**R44L** Woodpassion Beige  
15x90  
**R1ZZ** Woodpassion Beige rettificato  
14,5x90



**R44M** Woodpassion Brown  
15x90  
**R21Z** Woodpassion Brown rettificato  
14,5x90



**R44N** Woodpassion Taupe  
15x90  
**R2AZ** Woodpassion Taupe rettificato  
14,5x90



**R44P** Woodpassion Ice  
15x90  
**R2EL** Woodpassion Ice rettificato  
14,5x90



**R44Q** Woodpassion Smoke  
15x90  
**R2EM** Woodpassion Smoke rettificato  
14,5x90

wood effect

## tech info

\*

Battiscopa ottenuto da taglio del fondo  
Skirting cut from plain tile  
Aus Grundfliese geschnittener Sockel  
Plinthe obtenue par découpe du fond  
Rodapié obtenido mediante corte del fondo  
Плинтус, полученный методом нарезания фоновой плитки



Apprezzabili differenze nell'aspetto di superficie e grafica all'interno della stessa produzione. / Clearly distinguishable differences in texture and pattern within the same production run. / Auffällige Unterschiede in Aussehen und Struktur innerhalb der gleichen Produktionscharge. / Différences visibles au niveau de l'aspect et de la fantaisie entre les carreaux du même lot de production. / Diferencias visibles en el aspecto de la superficie y los motivos dentro de un mismo lote de producción. / Заметные отличия вида поверхности и графики в одной и той же партии.

pezzi speciali / trims / spezialteile / pièces spéciales / piezas especiales / специальные изделия



BT.B.C.\*  
7,5x90

Woodpassion Beige	R44R
Woodpassion Brown	R44S
Woodpassion Taupe	R44T
Woodpassion Ice	R44U
Woodpassion Smoke	R44V

imballi / packaging / verpackungen / emballages / embalajes / упаковки

Scatole / Box / Karton / Boîte / Caja / Коробки	Pallet / Pallet / Palette / Palette / Pallet / Поддон
M <sup>2</sup>	KG
M <sup>2</sup>	KG
mm	

fondi / plain tiles / grundfliesen / fonds / fondos / фоновая плитка							
15x90	8	1,08	19,35	48	51,84	928,80	8
14,5x90 rett.	8	1,04	18,96	48	50,11	910,00	8
pezzi speciali / trims / spezialteile / pièces spéciales / piezas especiales / специальные изделия							
7,5x90 BT.B.C.	15	13,5 ml	24,10				8

# Woodcraft

10x70



R4LY Woodcraft Marrone 10x70

wood effect

# Woodcraft

10x70

Gruppo Bla UNI EN 14411\_G

gres porcellanato / porcelain stoneware / feinsteinzeug / grès cérame émaillé / gres porcelánico / керамогранит

superfici / surfaces / finitions / oberflächen / superficies / поверхности:  
naturale/matt + outdoor



H

R4LZ Woodcraft Beige  
10x70



G

R4LY Woodcraft Marrone  
10x70



G

R520 Woodcraft Beige Grip  
10x70



H

R4MA Woodcraft Bianco  
10x70



H

R4LW Woodcraft Grigio  
10x70



H

R4LX Woodcraft Antracite  
10x70



G

R51Z Woodcraft Grigio Grip  
10x70

## tech info

\*

Battiscopa ottenuto da taglio del fondo  
Skirting cut from plain tile  
Aus Grundfliese geschnittener Sockel  
Plinthe obtenue par découpe du fond  
Rodapié obtenido mediante corte del fondo  
Плинтус, полученный методом нарезания фоновой плитки



Variazioni irregolari da piastrella a piastrella. Una piastrella può differire totalmente nell'aspetto superficiale e colore da un'altra. Si consiglia di visionare la gamma cromatica prima della selezione del materiale. / Random differences from tile to tile. One tile may have totally different texture and colour from another. The colour range should be viewed before selecting the material. / Wesentliche Variationen von Fliese zu Fliese. Eine Fliese kann sich in Aussehen und Farbe komplett von einer anderen unterscheiden. Es wird empfohlen, das Farbsortiment vor der Auswahl des Materials zu prüfen. / Variations irrégulières entre les carreaux. L'aspect et la couleur peuvent être complètement différents d'un carreau à l'autre. Il est recommandé de consulter la gamme des couleurs avant de sélectionner le matériel. / Variaciones irregulares entre un azulejo y otro. Un azulejo puede ser completamente diferente de otro en el aspecto superficial y el color. Es aconsejable visualizar la gama cromática antes de seleccionar el material. / Неоднородные изменения на разных плитках. Каждая плитка может полностью отличаться по виду поверхности и цвету от другой. Перед отбором материала рекомендуется просмотреть цветовую гамму.

pezzi speciali / trims / spezialteile / pièces spéciales / piezas especiales / специальные изделия



BT.B.C.\*  
5x70

Woodcraft Beige	R4ND
Woodcraft Marrone	R4NC
Woodcraft Bianco	R4NE
Woodcraft Grigio	R4MZ
Woodcraft Antracite	R4NA

imballi / packaging / verpackungen / emballages / embalajes / упаковки

Scatole / Box / Karton / Boite / Caja / Коробки

Pallet / Pallet / Palette / Palette / Pallet / Поддон

	M <sup>2</sup>	KG	M <sup>2</sup>	KG	≠ mm
<b>fondi</b> / plain tiles / grundfliesen / fonds / fondos / фоновая плитка					
10x70	17	1,19	21,00	48	57,12 1008,00
10x70 grip	17	1,19	21,00	48	57,12 1008,00
<b>pezzi speciali</b> / trims / spezialteile / pièces spéciales / piezas especiales / специальные изделия					
5x70	15	10,50 ml	12,76		8

Per le pavimentazioni esterne non protette, Ragno consiglia di creare una pendenza ≥ 1,5% sulla superficie calpestabile allo scopo di limitare il formarsi di ristagni d'acqua localizzati. Nel caso in cui questi ristagni permangano sulla superficie delle piastrelle nonostante una posa a regola d'arte, è necessario intervenire meccanicamente con l'utilizzo di scope o aspira-liquidi. / For unprotected outdoor pavings, Ragno recommends the creation of a gradient of ≥ 1.5% on the finished surface, to prevent the formation of patches of standing water. In the event that standing water persists on the surface of the tiles in spite of correct installation, it must be removed mechanically with the aid of brooms or wet-and-dry vacuum cleaners. / Zur Unterbindung von punktueller Stauwasserbildung bei Belägen in ungeschützten Außenbereichen, empfiehlt die Ragno die Ausbildung eines Gefälles ≥ 1,5% auf der Trittläche. Sollte trotz fachgerechter Verlegung Stauwasser auf der Fliesenoberfläche zurückbleiben, ist dessen mechanische Entfernung mit Hilfe eines Besens oder Nasssaugers erforderlich. / Pour des sols extérieurs non protégés, Ragno conseille de créer une inclinaison ≥ 1,5 % sur la surface de piétinement en vue de limiter la stagnation localisée de l'eau. Si, malgré une pose dans les règles de l'art, cette stagnation devait persister à la surface des carreaux, une intervention mécanique, au moyen de balais et d'aspirateurs de liquides, est alors nécessaire. / En el caso de pavimentaciones exteriores no protegidas, Ragno recomienda crear una pendiente ≥ 1,5% en la superficie transitable para limitar la formación de depósitos localizados de agua estancada. En caso de que estos depósitos de agua permanezcan en la superficie del azulejo, aun cuando la colocación se haya realizado correctamente, será necesario intervenir mecánicamente empleando un cepillo o un aspirador de líquidos. / Для наружных незащищенных полов Ragno рекомендует создавать уклон ≥ 1,5% на пешеходной поверхности для снижения образования локальных застоев воды. В случае, если застои воды образуются на плитке несмотря на правильную укладку, необходимо прибегать к использованию механических средств, таких как щетки или же аппараты для сбора жидкостей.

# Woodessence

10x70



Gruppo Bla UNI EN 14411\_G

gres porcellanato / porcelain stoneware / feinsteinzeug / grès cérame émaillé / gres porcelánico / керамогранит

superfici / surfaces / finitions / oberflächen / superficies / поверхности:  
naturale/matt



R4MC Woodessence Beige 10x70



H

R4MC Woodessence Beige  
10x70



H

R4ME Woodessence Brown  
10x70



H

R4MD Woodessence Grey  
10x70



H

R4MF Woodessence Honey  
10x70



G

R4MG Woodessence Walnut  
10x70

wood effect

## tech info

\*

Battiscopa ottenuto da taglio del fondo  
Skirting cut from plain tile  
Aus Grundfliese geschnittener Sockel  
Plinthe obtenue par découpe du fond  
Rodapié obtenido mediante corte del fondo  
Плинтус, полученный методом нарезания фоновой плитки



Apprezzabili differenze nell'aspetto di superficie e grafica all'interno della stessa produzione. / Clearly distinguishable differences in texture and pattern within the same production run. / Auffällige Unterschiede in Aussehen und Struktur innerhalb der gleichen Produktionscharge. / Différences visibles au niveau de l'aspect et de la fantaisie entre les carreaux du même lot de production. / Diferencias visibles en el aspecto de la superficie y los motivos dentro de un mismo lote de producción. / Заметные отличия вида поверхности и графики в одной и той же партии.

pezzi speciali / trims / spezialteile / pièces spéciales / piezas especiales / специальные изделия

imballi / packaging / verpackungen / emballages / embalajes / упаковки



BT.B.C.\*  
5x70

Woodessence Beige	R4MU
Woodessence Brown	R4MW
Woodessence Grey	R4MV
Woodessence Honey	R4MX
Woodessence Walnut	R4MY

Scatole / Box / Karton / Boite / Caja / Коробки Pallet / Pallet / Palette / Palette / Pallet / Поддон



fondi / plain tiles / grundfliesen / fonds / fondos / фоновая плитка							
10x70	17	1,19	21,00	48	57,12	1008,00	8
pezzi speciali / trims / spezialteile / pièces spéciales / piezas especiales / специальные изделия							
5x70	BT.B.C.	15	10,50 ml	12,76			8

# Woodglam

10x70

Gruppo Bia UNI EN 14411\_G

gres porcellanato / porcelain stoneware / feinsteinzeug / grès cérame émaillé / gres porcelánico / керамогранит

superfici / surfaces / finitions / oberflächen / superficies / поверхности: **naturale/matt**

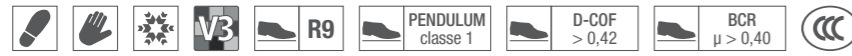

R06P Woodglam Naturale 10x70



G

R06P Woodglam Naturale  
10x70



H

R06Q Woodglam Tortora  
10x70



H

R06R Woodglam Noce  
10x70



H

R06N Woodglam Grigio  
10x70

wood effect

## tech info

★

Battiscopa ottenuto da taglio del fondo  
Skirting cut from plain tile  
Aus Grundfliese geschnittener Sockel  
Plinthe obtenue par découpe du fond  
Rodapié obtenido mediante corte del fondo  
Плинтус, полученный методом нарезания фоновой плитки



Significativa variazione di aspetto superficiale, grafica e colore da piastrella a piastrella e all'interno della stessa piastrella. Si consiglia di visionare la gamma cromatica prima della selezione del materiale. / Significant variation in texture, pattern and colour from tile to tile within the same production run. The colour range should be viewed before selecting the material. / Bedeutende Variation in Aussehen, Struktur und Farbe von Fliese zu Fliese und in ein und derselben Fliese. Es wird empfohlen, das Farbsortiment vor der Auswahl des Materials zu prüfen. / Variation significative au niveau de l'aspect, de la fantaisie et de la couleur entre les carreaux et au sein d'un même carreau. Il est recommandé de consulter la gamme des couleurs avant de sélectionner le matériel. / Variación considerable en el aspecto superficial, los motivos y el color entre un azulejo y otro y dentro del propio azulejo. Es aconsejable visualizar la gama cromática antes de seleccionar el material. / Значительные отличия вида поверхности, графики и цвета у разных плиток и на одной и той же плитке. Перед отбором материала рекомендуется посмотреть цветовую гамму.

pezzi speciali / trims / spezialteile / pièces spéciales / piezas especiales / специальные изделия



BT.B.C.\*  
5x70

Woodglam Naturale	R06T
Woodglam Tortora	R06U
Woodglam Noce	R06V
Woodglam Grigio	R06S

imballi / packaging / verpackungen / emballages / embalajes / упаковки

Scatole / Box / Karton /  
Boite / Caja / Коробки

Pallet / Pallet / Palette /  
Palette / Pallet / Поддон

	M <sup>2</sup>	KG		M <sup>2</sup>	KG	# mm
--	----------------	----	--	----------------	----	---------

fondi / plain tiles / grundfliesen / fonds / fondos / фоновая плитка							
10x70	17	1,19	21,00	48	57,12	1008,00	8
pezzi speciali / trims / spezialteile / pièces spéciales / piezas especiales / специальные изделия							
5x70	BT.B.C.	15	10,50 ml	12,76			8

# Woodchoice

11x54



Gruppo Bla UNI EN 14411\_G

gres porcellanato / porcelain stoneware / feinsteinzeug / grès cérame émaillé / gres porcelánico / керамогранит

superfici / surfaces / finitions / oberflächen / superficies / поверхности:  
naturale/matt



R17H Woodchoice Chevron Milk 11x54



R17H Woodchoice Chevron Milk  
11x54



R17J Woodchoice Chevron Sugar  
11x54



R17K Woodchoice Chevron Coconut  
11x54

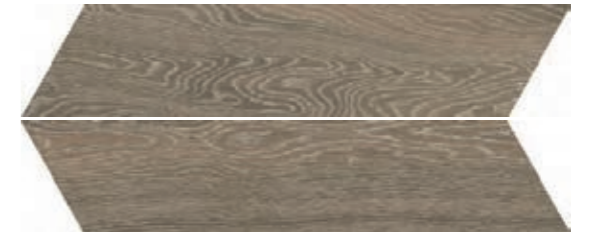

R17L Woodchoice Chevron Tea  
11x54



R17M Woodchoice Chevron Salt  
11x54



## tech info

\*

Battiscopa ottenuto per pressatura / Pressed skirting tile / Gepresster Sockel  
Plinthe obtenue par pressage / Rodapié obtenido mediante prensado /  
Плинтус, полученный в результате прессовки



Significativa variazione di aspetto superficiale, grafica e colore da piastrella a piastrella e all'interno della stessa piastrella. Si consiglia di visionare la gamma cromatica prima della selezione del materiale. / Significant variation in texture, pattern and colour from tile to tile within the same production run. The colour range should be viewed before selecting the material. / Bedeutende Variation in Aussehen, Struktur und Farbe von Fliese zu Fliese und in ein und derselben Fliese. Es wird empfohlen, das Farbsortiment vor der Auswahl des Materials zu prüfen. / Variation significative au niveau de l'aspect, de la fantaisie et de la couleur entre les carreaux et au sein d'un même carreau. Il est recommandé de consulter la gamme des couleurs avant de sélectionner le matériel. / Variación considerable en el aspecto superficial, los motivos y el color entre un azulejo y otro y dentro del propio azulejo. Es aconsejable visualizar la gama cromática antes de seleccionar el material. / Значительные отличия вида поверхности, графики и цвета у разных плиток и на одной и той же плитке. Перед отбором материала рекомендуется просмотреть цветовую гамму.

pezzi speciali / trims / spezialteile / pièces spéciales /  
piezas especiales / специальные изделия



BT.B.C.\*  
7,5x60

Woodchoice Milk	R6MU
Woodchoice Sugar	R6MV
Woodchoice Coconut	R6MX
Woodchoice Tea	R6MY
Woodchoice Salt	R6MW

imballi / packaging / verpackungen / emballages /  
embalajes / упаковки

Scatole / Box / Karton /  
Boîte / Caja / Коробки

Pallet / Pallet / Palette /  
Palette / Pallet / Поддон



fondi / plain tiles / grundfliesen / fonds / fondos / фоновая плитка							
11x54	18	0,94	18,09	45	42,44	813,88	9
pezzi speciali / trims / spezialteile / pièces spéciales / piezas especiales / специальные изделия							
7,5x60	16	9,60	14,40				8,5



Style Book Products

## XT 20

*Extra Spessore 20mm*

*Extra thickness 20 mm*

*Überstärke 20mm*

*Épaisseur extra 20 mm*

*Grosor extra de 20 mm*

*Увеличенная толщина 20 мм*

# Realstone\_Lunar XT20

50x100



Gruppo Bia UNI EN 14411\_G

gres fine porcellanato colorato in massa - rettificato monocalibro / colorbody fine porcelain stoneware - rectified monocaliber / durchgefärbtes feinsteinzeug - rektifiziert, in einem werkmaß / grès cérame fin coloré dans la masse - rectifié monocalibre / gres porcelánico fino coloreado en toda la masa - rectificado monocalibre / гомогенный мелкозернистый керамогранит - ректифицированный монокалиберный

superfici / surfaces / finitions / oberflächen / superficies / поверхности:

outdoor

Stepwise



R7DT Realstone\_Lunar XT20 Beige rettificato 50x100



R7DS Lunar XT20 White rettificato  
50x100

H



R7DT Lunar XT20 Beige rettificato  
50x100

H



R7DU Lunar XT20 Silver rettificato  
50x100

H

XT20



# Realstone\_Lunar XT20

50x100

Gruppo Bia UNI EN 14411\_G

gres fine porcellanato colorato in massa - rettificato monocalibro / colorbody fine porcelain stoneware - rectified monocaliber / durchgefärbtes feinsteinzeug - rektifiziert, in einem werkmaß / grès cérame fin coloré dans la masse - rectifié monocalibre / gres porcelánico fino coloreado en toda la masa - rectificado monocalibre / гомогенный мелкозернистый керамогранит - ректифицированный монокалиберный

superfici / surfaces / finitions / oberflächen / superficies / поверхности:  
outdoor

Stepwise

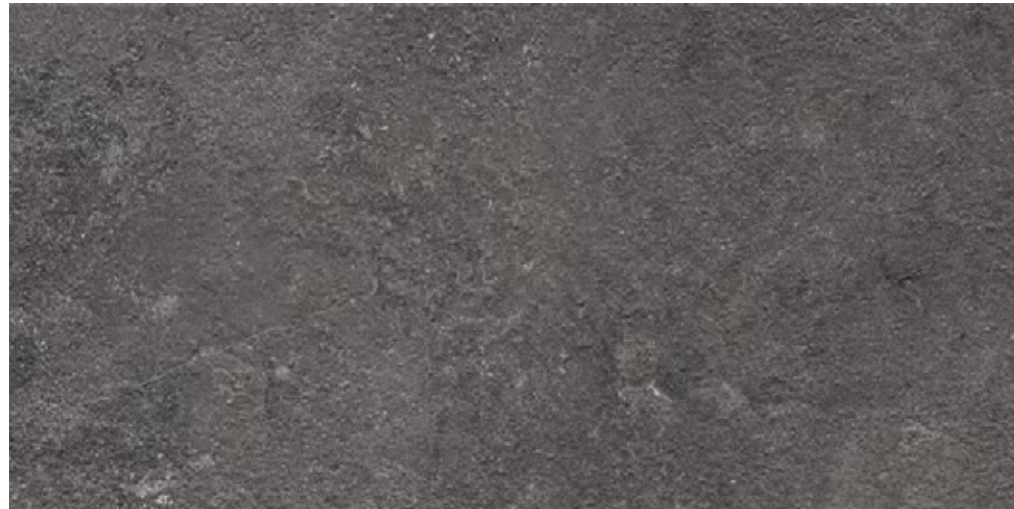

R7DV Lunar XT20 Deep Grey rettificato  
50x100

H

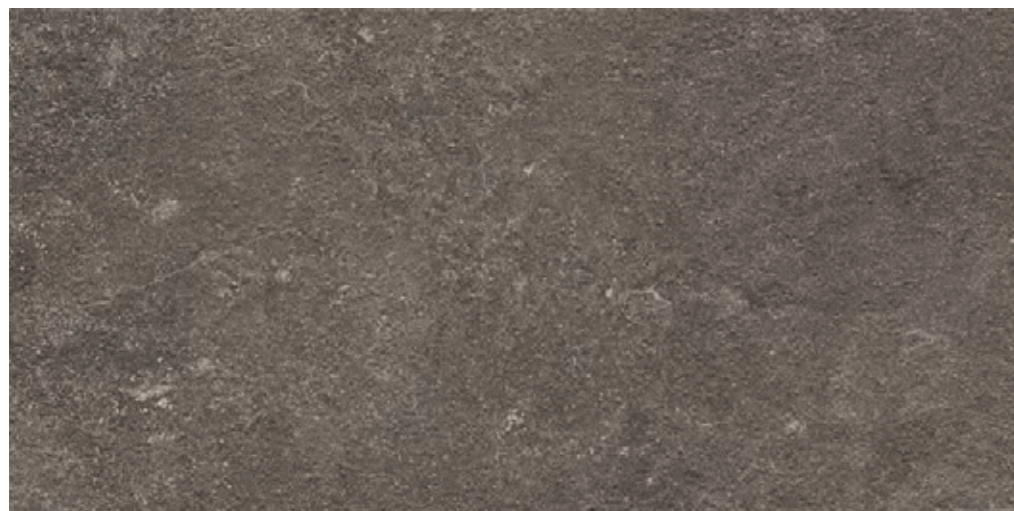

R7DW Lunar XT20 Uniform rettificato  
50x100

H

## tech info

\*  
Assemblato / Two-piece L-tile / Randstein zweiteilig /  
Assemblé / Montado / Собранный



Apprezzabili differenze nell'aspetto di superficie e grafica all'interno della stessa produzione. / Clearly distinguishable differences in texture and pattern within the same production run. / Auffällige Unterschiede in Aussehen und Struktur innerhalb der gleichen Produktionscharge. / Différences visibles au niveau de l'aspect et de la fantaisie entre les carreaux du même lot de production. / Diferencias visibles en el aspecto de la superficie y los motivos dentro de un mismo lote de producción. / Заметные отличия вида поверхности и графики в одной и той же партии.

imballi / packaging / verpackungen / emballages /  
embalajes / упаковки

Scatole / Box / Karton / Pallet / Pallet / Palette /  
Boite / Caja / Коробки Palette / Pallet / Поддон

	<b>M<sup>2</sup></b>	<b>KG</b>		<b>M<sup>2</sup></b>	<b>KG</b>	<b>≠ mm</b>
--	----------------------	-----------	--	----------------------	-----------	-------------

fondi / plain tiles / grundfliesen / fonds / fondos / фоновая плитка	1	0,50	22,72	50	25,00	1135,85	20
50x100							

## pezzi speciali / trims / spezialteile / pièces spéciales / piezas especiales / специальные изделия

	GRADONE* STEP TILE* 40x100	GRADONE* STEP TILE* 40x100	GRADONE* STEP TILE* 40x100	GRADONE* STEP TILE* 40x100	ALZATA RISER TILE 20x100	ALZATA RISER TILE 20x100	ALZATA RISER TILE 20x100
LAVORAZIONE LATI TAGLIO + ASSEMBLAGGIO EDGES PRODUCED BY CUTTING + ASSEMBLY	SOLO SU LATO LUNGO ON LONG SIDE ONLY	LATO LUNGO + SX LONG SIDE + L	LATO LUNGO + DX LONG SIDE + R	LATO LUNGO + DX + SX LONG SIDE + R + L	NESSUN LATO LAVORATO NO SHAPED EDGES	ENTRAMBI I LATI CORTI BOTH SHORT SIDES	DX/SX RIBALTABILE RL REVERSIBLE
Lunar XT20 White	R7TG	R7TN	R7TV	R7UX	R7VE	R7VP	R7VV
Lunar XT20 Beige	R7TH	R7TP	R7UA	R7UY	R7VG	R7VQ	R7VW
Lunar XT20 Silver	R7TJ	R7TQ	R7UD	R7UZ	R7VJ	R7VR	R7VX
Lunar XT20 Deep Grey	R7TK	R7TR	R7UG	R7VA	R7VL	R7VS	R7VY
Lunar XT20 Uniform	R7TL	R7TT	R7UH	R7VC	R7VM	R7VT	R7VZ
	COPRI MURETTO COPING TILE 40x100	COPRI MURETTO COPING TILE 40x100	ELEMENTO ELLE* L-EDGING TILE* 15x100x4	BORDO U* U-EDGING TILE* 15x50x15	CORDOLO L* L-KERB TILE* 15x50x20	CANALINA* GUTTER TILE* 15x50x8	GRIGLIA GRID TILE 15x50
LAVORAZIONE ROMPIGOCCIA NON-DRIP EDGE	SU 2 LATI LUNGH ON THE 2 LONG SIDES	SU 3 LATI ON 3 SIDES					
Lunar XT20 White	R7WC	R7WJ	R7SX	R7YV	R7WQ	R7ZC	R7ZJ
Lunar XT20 Beige	R7WD	R7WK	R7TA	R7YW	R7WS	R7ZD	R7ZK
Lunar XT20 Silver	R7WE	R7WL	R7TC	R7YX	R7YQ	R7ZE	R7ZL
Lunar XT20 Deep Grey	R7WF	R7WM	R7TD	R7YY	R7YS	R7ZF	R7ZM
Lunar XT20 Uniform	R7WG	R7WN	R7TE	R7YZ	R7YT	R7ZG	R7ZN

Tutti i pezzi speciali sono su richiesta e sono coordinabili ai fondi rettificati. Gli imballi vengono calcolati sulla base del quantitativo ordinato.

All special pieces are supplied to order and can be matched with the rectified plain tiles. Packaging is calculated on the basis of the quantity ordered.

Alle Formteile sind auf Anfrage erhältlich und mit den rektifizierten Grundfliesen kombinierbar. Die Verpackung wird auf der Grundlage der Bestellmenge berechnet.

Toutes les pièces spéciales sont fabriquées sur demande et coordonnables aux fonds rectifiés. Les emballages sont calculés en fonction de la quantité commandée.

Todas las piezas especiales se entregan bajo pedido y se pueden coordinar con los fondos rectificados. Los embalajes se calculan según las cantidades encargadas en los pedidos.

Все специальные изделия производятся на заказ и сочетаются с обрезной фоновой плиткой. Упаковки рассчитываются на основе заказанного количества.

Per le pavimentazioni esterne non protette, Ragno consiglia di creare una pendenza  $\geq 1,5\%$  sulla superficie calpestabile allo scopo di limitare il formarsi di ristagni d'acqua localizzati. Nel caso in cui questi ristagni permangano sulla superficie delle piastrelle nonostante una posa a regola d'arte, è necessario intervenire meccanicamente con l'utilizzo di scope o aspira-liquidi. / For unprotected outdoor pavings, Ragno recommends the creation of a gradient of  $\geq 1.5\%$  on the finished surface, to prevent the formation of patches of standing water. In the event that standing water persists on the surface of the tiles in spite of correct installation, it must be removed mechanically with the aid of brooms or wet-and-dry vacuum cleaners. / Zur Unterbindung von punktueller Stauwasserbildung bei Belägen in ungeschützten Außenbereichen, empfiehlt die Ragno die Ausbildung eines Gefälles  $\geq 1,5\%$  auf der Trittlfläche. Sollte trotz fachgerechter Verlegung Stauwasser auf der Fliesenoberfläche zurückbleiben, ist dessen mechanische Entfernung mit Hilfe eines Besens oder Nasssaugers erforderlich. / Pour des sols extérieurs non protégés, Ragno conseille de créer une inclinaison  $\geq 1,5\%$  sur la surface de piétinement en vue de limiter la stagnation localisée de l'eau. Si, malgré une pose dans les règles de l'art, cette stagnation devait persister à la surface des carreaux, une intervention mécanique, au moyen de balais et d'aspirateurs de liquides, est alors nécessaire. / En el caso de pavimentaciones exteriores no protegidas, Ragno recomienda crear una pendiente  $\geq 1,5\%$  en la superficie transitable para limitar la formación de depósitos localizados de agua estancada. En caso de que estos depósitos de agua permanezcan en la superficie del azulejo, aun cuando la colocación se haya realizado correctamente, será necesario intervenir mecánicamente empleando un cepillo o un aspirador de líquidos. / Для наружных незащищенных полов Ragno рекомендует создавать уклон  $\geq 1,5\%$  на пешеходной поверхности для снижения образования локальных застоев воды. В случае, если застои воды образуются на плитке несмотря на правильную укладку, необходимо прибегать к использованию механических средств, таких как щетки или же аппараты для сбора жидкостей.

# Realstone\_Navigli XT20

60x120 80x80



Gruppo Bia UNI EN 14411\_G

gres fine porcellanato colorato in massa - rettificato monocalibro / colorbody fine porcelain stoneware - rectified monocaliber / durchgefärbtes feinsteinzeug - rektifiziert, in einem werkmaß / grès cérame fin coloré dans la masse - rectifié monocalibre / gres porcelánico fino coloreado en toda la masa - rectificado monocalibre / гомогенный мелкозернистый керамогранит - ректифицированный монокалиберный

superfici / surfaces / finitions / oberflächen / superficies / поверхности:

outdoor

Stepwise



R7KX Navigli XT20 Grigio rettificato  
60x120

H



R7KY Navigli XT20 Naturale rettificato  
60x120

H

# Realstone\_Navigli XT20

60x120 80x80

gres fine porcellanato colorato in massa - rettificato monocoloro / colorbody fine porcelain stoneware - rectified monocolor / durchgefärbtes feinsteinzeug - rektifiziert, in einem werkmaß / grès cérame fin coloré dans la masse - rectifié monocolor / gres porcelánico fino coloreado en toda la masa - rectificado monocolor / гомогенный мелкозернистый керамогранит - ректифицированный монокалиберный

superfici / surfaces / finitions / oberflächen / superficies / поверхности:  
outdoor

Stepwise

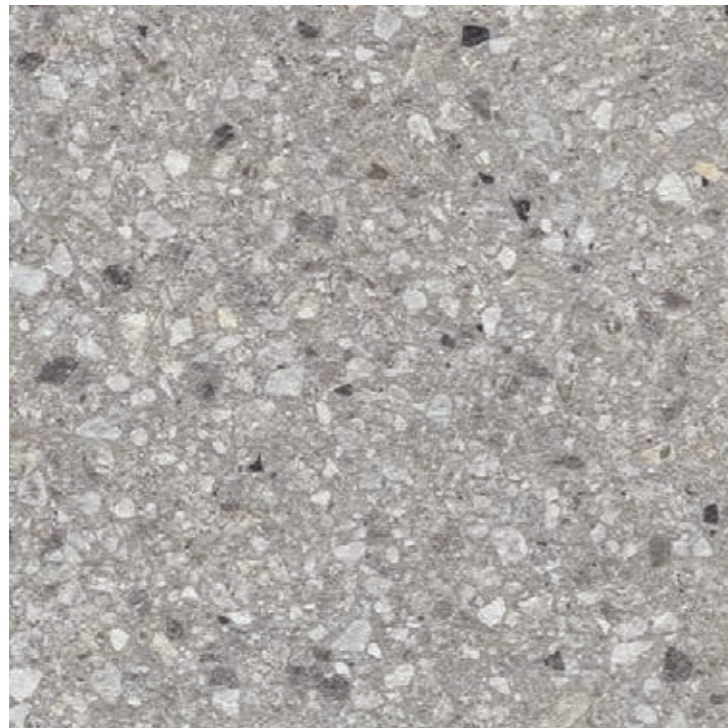

R7KA Navigli XT20 Grigio rettificato 80x80

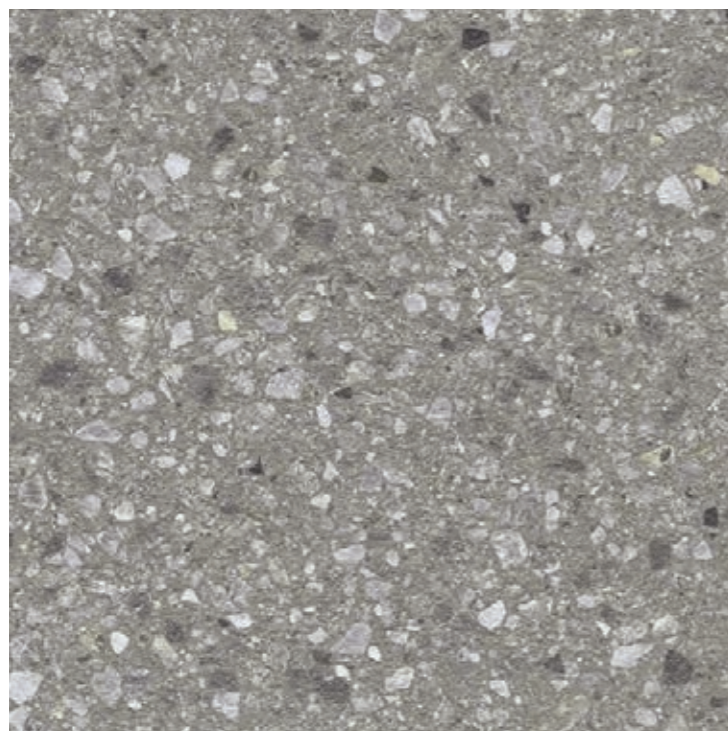

R7KC Navigli XT20 Naturale rettificato 80x80



## tech info

★

Assemblato / Two-piece L-tile / Randstein zweiteilig / Assemblé / Montado / Собранный



Apprezzabili differenze nell'aspetto di superficie e grafica all'interno della stessa produzione. / Clearly distinguishable differences in texture and pattern within the same production run. / Auffällige Unterschiede in Aussehen und Struktur innerhalb der gleichen Produktionscharge. / Différences visibles au niveau de l'aspect et de la fantaisie entre les carreaux du même lot de production. / Diferencias visibles en el aspecto de la superficie y los motivos dentro de un mismo lote de producción. / Заметные отличия вида поверхности и графики в одной и той же партии.

## imballi / packaging / verpackungen / emballages / embalajes / упаковки

Scatole / Box / Karton / Boite / Caja / Коробки

Pallet / Pallet / Palette / Palette / Поддон

	<b>M<sup>2</sup></b>	<b>KG</b>		<b>M<sup>2</sup></b>	<b>KG</b>	<b>≠ mm</b>
--	----------------------	-----------	--	----------------------	-----------	-------------

## fondi / plain tiles / grundfliesen / fonds / fondos / фоновая плитка

60x120	1	0,72	35,00	36	25,92	1260,08	20
80x80	1	0,64	30,50	45	28,80	1373,00	20

## pezzi speciali / trims / spezialteile / pièces spéciales / piezas especiales / специальные изделия

LAVORAZIONE LATI TAGLIO + ASSEMBLAGGIO EDGES PRODUCED BY CUTTING + ASSEMBLY	SOLO SU LATO LUNGO ON LONG SIDE ONLY	LATO LUNGO + SX LONG SIDE + L	LATO LUNGO + DX LONG SIDE + R	LATO LUNGO + DX + SX LONG SIDE + R + L	SOLO SU LATO LUNGO ON LONG SIDE ONLY	LATO LUNGO + SX LONG SIDE + L	LATO LUNGO + DX LONG SIDE + R	LATO LUNGO + DX + SX LONG SIDE + R + L
Navigli XT20 Grigio	R7XS	R7XV	R7XY	R7YC	R7RY	R7RS	R7RV	R7SA
Navigli XT20 Naturale	R7XT	R7XW	R7XZ	R7YD	R7RZ	R7RT	R7RW	R7SC
LAVORAZIONE LATI EDGE SHAPING	NESSUN LATO LAVORATO NO SHAPED EDGES	ENTRABI LATI CORTI BOTH SHORT SIDES	DX/SX RIBALTABILE RL REVERSIBLE	NESSUN LATO LAVORATO NO SHAPED EDGES	ENTRABI LATI CORTI BOTH SHORT SIDES	DX/SX RIBALTABILE RL REVERSIBLE	DX/SX RIBALTABILE RL REVERSIBLE	DX/SX RIBALTABILE RL REVERSIBLE
Navigli XT20 Grigio	R7YF	R7YJ	R80H	R7SE	R7SH	R7SL		
Navigli XT20 Naturale	R7YG	R7YK	R80J	R7SF	R7SJ	R7SM		
LAVORAZIONE ROMPIGOCCIA NON-DRIP EDGE	SU 2 LATI LUNGH ON THE 2 LONG SIDES	SU 3 LATI ON 3 SIDES	SU 2 LATI LUNGH ON THE 2 LONG SIDES	SU 3 LATI ON 3 SIDES				
Navigli XT20 Grigio	R81F	R80L	R7SS	R7SP	R7VF	R7RD		
Navigli XT20 Naturale	R81G	R80M	R7ST	R7SQ	R7VH	R7RF		
Navigli XT20 Grigio	R81M	R7UC	R81J	R7TW	R81T	R7UN	R81Q	R7UJ
Navigli XT20 Naturale	R81N	R7UE	R81K	R7TX	R81U	R7UP	R81R	R7UK

Tutti i pezzi speciali sono su richiesta e sono coordinabili ai fondi rettificati. Gli imballi vengono calcolati sulla base del quantitativo ordinato.

All special pieces are supplied to order and can be matched with the rectified plain tiles. Packaging is calculated on the basis of the quantity ordered.

Alle Formteile sind auf Anfrage erhältlich und mit den rektifizierten Grundfliesen kombinierbar. Die Verpackung wird auf der Grundlage der Bestellmenge berechnet.

Toutes les pièces spéciales sont fabriquées sur demande et coordonnables aux fonds rectifiés. Les emballages sont calculés en fonction de la quantité commandée.

Todas las piezas especiales se entregan bajo pedido y se pueden coordinar con los fondos rectificados. Los embalajes se calculan según las cantidades encargadas en los pedidos.

Всё специальные изделия производятся на заказ и сочетаются с обрезной фоновой плиткой. Упаковки рассчитываются на основе заказанного количества.

Per le pavimentazioni esterne non protette, Ragno consiglia di creare una pendenza  $\geq 1,5\%$  sulla superficie calpestabile allo scopo di limitare il formarsi di ristagni d'acqua localizzati. Nel caso in cui questi ristagni permangano sulla superficie delle piastrelle nonostante una posa a regola d'arte, è necessario intervenire meccanicamente con l'utilizzo di scope o aspira-liquidi. / For unprotected outdoor pavings, Ragno recommends the creation of a gradient of  $\geq 1,5\%$  on the finished surface, to prevent the formation of patches of standing water. In the event that standing water persists on the surface of the tiles in spite of correct installation, it must be removed mechanically with the aid of brooms or wet-and-dry vacuum cleaners. / Zur Unterbindung von punktueller Stauwasserbildung bei Belägen in ungeschützten Außenbereichen, empfiehlt die Ragno die Ausbildung eines Gefälles  $\geq 1,5\%$  auf der Trittfäche. Sollte trotz fachgerechter Verlegung Stauwasser auf der Fliessenoberfläche zurückbleiben, ist dessen mechanische Entfernung mit Hilfe eines Besens oder Nasssaugers erforderlich. / Pour des sols extérieurs non protégés, Ragno conseille de créer une inclinaison  $\geq 1,5\%$  sur la surface de piétinement en vue de limiter la stagnation localisée de l'eau. Si, malgré une pose dans les règles de l'art, cette stagnation devait persister à la surface des carreaux, une intervention mécanique, au moyen de balais et d'aspirateurs de liquides, est alors nécessaire. / En el caso de pavimentaciones exteriores no protegidas, Ragno recomienda crear una pendiente  $\geq 1,5\%$  en la superficie transitable para limitar la formación de depósitos localizados de agua estancada. En caso de que estos depósitos de agua permanezcan en la superficie del azulejo, aun cuando la colocación se haya realizado correctamente, será necesario intervenir mecánicamente empleando un cepillo o un aspirador de líquidos. / Для наружных незащищенных полов Ragno рекомендует создавать уклон  $\geq 1,5\%$  на пешеходной поверхности для снижения образования локальных застоев воды. В случае, если застои воды образуются на плитке несмотря на правильную укладку, необходимо прибегать к использованию механических средств, таких как щетки или же аппараты для сбора жидкостей.

# Realstone\_PietrAntica XT20

60x120



R7KJ Realstone\_PietrAntica XT20 Beige rettificato 60x120  
R48F Realstone\_PietrAntica XT20 Beige Griglia 15x60  
R83W Realstone\_PietrAntica XT20 Beige Canalina 15x60x8

# Realstone\_PietrAntica XT20

60x120



Gruppo Bia UNI EN 14411\_G

gres fine porcellanato colorato in massa - rettificato monocalibro / colorbody fine porcelain stoneware - rectified monocaliber / durchgefärbtes feinsteinzeug - rektifiziert, in einem werkmaß / grès cérame fin coloré dans la masse - rectifié monocalibre / gres porcelánico fino coloreado en toda la masa - rectificado monocalibre / гомогенный мелкозернистый керамогранит - ректифицированный монокалиберный

superfici / surfaces / finitions / oberflächen / superficies / поверхности:  
outdoor



R7KG PietrAntica XT20 White rettificato  
60x120

H



R7KJ PietrAntica XT20 Beige rettificato  
60x120

H



R7KK PietrAntica XT20 Multicolor rettificato  
60x120

H



R7KU PietrAntica XT20 White Tumbled Edges \*  
60x210  
(1pz 60x120, 1pz 60x60, 1pz 30x60)

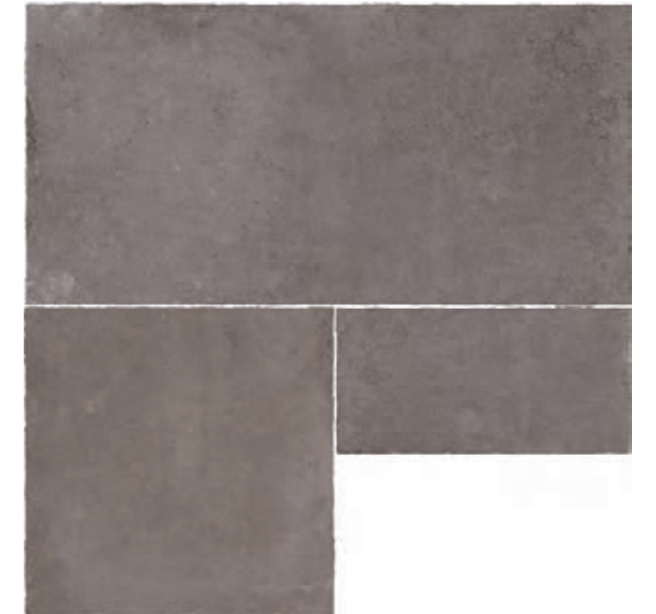

R7KR PietrAntica XT20 Multicolor Tumbled Edges \*  
60x210  
(1pz 60x120, 1pz 60x60, 1pz 30x60)



R7KV PietrAntica XT20 Beige Tumbled Edges \*  
60x210  
(1pz 60x120, 1pz 60x60, 1pz 30x60)

XT20

# Realstone\_PietrAntica XT20

60x120

gres fine porcellanato colorato in massa - rettificato monocolor / colorbody fine porcelain stoneware - rectified monocolor / durchgefärbtes feinsteinzeug - rektifiziert, in einem werkmaß / grès cérame fin coloré dans la masse - rectifié monocolor / gres porcelánico fino coloreado en toda la masa - rectificado monocolor / гомогенный мелкозернистый керамогранит - ректифицированный монокалиберный

superfici / surfaces / finitions / oberflächen / superficies / поверхности:  
outdoor



**R8DP** PietrAntica XT20 White rettificato \*  
60x120  
(1pz 60x120, 1pz 60x60, 1pz 30x60)



**R8DS** PietrAntica XT20 Multicolor rettificato \*  
60x120  
(1pz 60x120, 1pz 60x60, 1pz 30x60)



**R8DR** PietrAntica XT20 Beige rettificato \*  
60x120  
(1pz 60x120, 1pz 60x60, 1pz 30x60)

\*

La produzione di PietrAntica XT20 Tumbled Edges e Bordi Dritti è su richiesta. Ordine minimo: una cassa intera, pari a una superficie di 20,16 mq. / PietrAntica XT20 with Tumbled Edges and Straight Edges is produced to order. Order unit: whole crate, equal to a surface area of 20.16 m<sup>2</sup>. / Die Herstellung von PietrAntica XT20 Tumbled Edges und mit geraden Kanten erfolgt auf Anfrage. Mindestbestellmenge: 1 Kiste, entsprechend einer Fläche von 20,16 m<sup>2</sup>. / La production de PietrAntica XT20 Tumbled Edges et Bords droits se fait à la demande. Commande minimale : une caisse entière, équivalent à une superficie de 20,16 m<sup>2</sup>. / Las colecciones PietrAntica XT20 Tumbled Edges y Bordes Rectos se fabrican bajo pedido. Pedido mínimo: una caja entera, igual a una superficie de 20,16 m<sup>2</sup>. / Производство PietrAntica XT20 Tumbled Edges и с прямыми кромками осуществляется по заказу. Минимальный объем заказа: полный ящик, с площадью материала 20,16 кв.м.

## tech info

\*

Assemblato / Two-piece L-tile / Randstein zweiteilig / Assemblé / Montado / Собранная



Variazioni irregolari da piastrella a piastrella. Una piastrella può differire totalmente nell'aspetto superficiale e colore da un'altra. Si consiglia di visionare la gamma cromatica prima della selezione del materiale / Random differences from tile to tile. One tile may have totally different texture and colour from another. The colour range should be viewed before selecting the material. / Wesentliche Variationen von Fliese zu Fliese. Eine Fliese kann sich in Aussehen und Farbe komplett von einer anderen unterscheiden. Es wird empfohlen, das Farbsortiment vor der Auswahl des Materials zu prüfen. / Variations irrégulières entre les carreaux. L'aspect et la couleur peuvent être complètement différents d'un carreau à l'autre. Il est recommandé de consulter la gamme des couleurs avant de sélectionner le matériel. / Variaciones irregulares entre un azulejo y otro. Un azulejo puede ser completamente diferente de otro en el aspecto superficial y el color. Es aconsejable visualizar la gama cromática antes de seleccionar el material. / Неоднородные изменения на разных плитках. Каждая плитка может полностью отличаться по виду поверхности и цвету от другой. Перед отбором материала рекомендуется просмотреть цветовую гамму.



Apprezzabili differenze nell'aspetto di superficie e grafica all'interno della stessa produzione. / Clearly distinguishable differences in texture and pattern within the same production run. / Auffällige Unterschiede in Aussehen und Struktur innerhalb der gleichen Produktionscharge. / Différences visibles au niveau de l'aspect et de la fantaisie entre les carreaux du même lot de production. / Diferencias visibles en el aspecto de la superficie y los motivos dentro de un mismo lote de producción. / Заметные отличия вида поверхности и графики в одной и той же партии.

imballi / packaging / verpackungen / emballages / embalajes / упаковки

Scatole / Box / Karton / Boîte / Caja / Коробки	Pallet / Pallet / Palette / Palette / Pallet / Поддон
M2	KG
mm	

fondi / plain tiles / grundfliesen / fonds / fondos / фоновая плитка	60x120	rettificato	1	0,72	35,00	36	25,92	1260,00	20
60x120	tumbled edges / rett.	1	1,26	60,00	16	20,16	960,00	20	

## pezzi speciali / trims / spezialteile / pièces spéciales / piezas especiales / специальные изделия

	GRADONE* STEP TILE* 40x120	GRADONE* STEP TILE* 40x120	GRADONE* STEP TILE* 40x120	GRADONE* STEP TILE* 40x120	ALZATA RISER TILE 20x1020	ALZATA RISER TILE 20x120	ALZATA RISER TILE 20x120
LAVORAZIONE LATI TAGLIO + ASSEMBLAGGIO EDGES PRODUCED BY CUTTING + ASSEMBLY	SOLO SU LATO LUNGO ON LONG SIDE ONLY	LATO LUNGO + SX LONG SIDE + L	LATO LUNGO + DX LONG SIDE + R	LATO LUNGO + DX + SX LONG SIDE + R + L	NESSUN LATO LAVORATO NO SHAPED EDGES	ENTRAMBI I LATI CORTI BOTH SHORT SIDES	DX/SX RIBALTABILE RL REVERSIBLE
PietrAntica XT20 Bianco	R7ZV	R7ZZ	R803	R807	R80C	R80P	R80T
PietrAntica XT20 Beige	R7ZW	R800	R804	R808	R80D	R80Q	R80U
PietrAntica XT20 Multicolor	R7ZX	R801	R805	R809	R80E	R80R	R80V
	COPRI MURETTO COPING TILE 40x120	COPRI MURETTO COPING TILE 40x120	ELEMENTO ELLE* L-EDGING TILE* 15x120x4	BORDO U* U-EDGING TILE* 15x60x15	CORDOLO L* L-KERB TILE* 15x60x20	CANALINA* GUTTER TILE* 15x60x8	GRIGLIA GRID TILE 15x60
LAVORAZIONE ROMPIGOCCIA NON-DRIP EDGE	SU 2 LATI LUNGHI ON THE 2 LONG SIDES	SU 3 LATI ON 3 SIDES					
PietrAntica XT20 Bianco	R82Y	R80X	R7ZR	R83M	R83E	R83S	R84E
PietrAntica XT20 Beige	R82Z	R80Y	R7ZS	R83N	R83H	R83W	R84F
PietrAntica XT20 Multicolor	R83A	R80Z	R7ZT	R83P	R83K	R83X	R84G

Tutti i pezzi speciali sono su richiesta e sono coordinabili ai fondi rettificati. Gli imballi vengono calcolati sulla base del quantitativo ordinato.

All special pieces are supplied to order and can be matched with the rectified plain tiles. Packaging is calculated on the basis of the quantity ordered.

Alle Formteile sind auf Anfrage erhältlich und mit den rektifizierten Grundfliesen kombinierbar. Die Verpackung wird auf der Grundlage der Bestellmenge berechnet.

Toutes les pièces spéciales sont fabriquées sur demande et coordonnables aux fonds rectifiés. Les emballages sont calculés en fonction de la quantité commandée.

Todas las piezas especiales se entregan bajo pedido y se pueden coordinar con los fondos rectificados. Los embalajes se calculan según las cantidades encargadas en los pedidos.

Все специальные изделия производятся на заказ и сочетаются с обрезной фоновой плиткой. Упаковки рассчитываются на основе заказанного количества.

Per le pavimentazioni esterne non protette, Ragno consiglia di creare una pendenza  $\geq 1,5\%$  sulla superficie calpestabile allo scopo di limitare il formarsi di ristagni d'acqua localizzati. Nel caso in cui questi ristagni permangano sulla superficie delle piastrelle nonostante una posa a regola d'arte, è necessario intervenire meccanicamente con l'utilizzo di scope o aspira-liquidi. / For unprotected outdoor pavings, Ragno recommends the creation of a gradient of  $\geq 1,5\%$  on the finished surface, to prevent the formation of patches of standing water. In the event that standing water persists on the surface of the tiles in spite of correct installation, it must be removed mechanically with the aid of brooms or wet-and-dry vacuum cleaners. / Zur Unterbindung von punktueller Stauwasserbildung bei Belägen in ungeschützten Außenbereichen, empfiehlt die Ragno die Ausbildung eines Gefälles  $\geq 1,5\%$  auf der Trittlfläche. Sollte trotz fachgerechter Verlegung Stauwasser auf der Fliesenoberfläche zurückbleiben, ist dessen mechanische Entfernung mit Hilfe eines Besens oder Nasssaugers erforderlich. / Pour des sols extérieurs non protégés, Ragno conseille de créer une inclinaison  $\geq 1,5\%$  sur la surface de piétinement en vue de limiter la stagnation localisée de l'eau. Si, malgré une pose dans les règles de l'art, cette stagnation devait persister à la surface des carreaux, une intervention mécanique, au moyen de balais et d'aspirateurs de liquides, est alors nécessaire. / En el caso de pavimentaciones exteriores no protegidas, Ragno recomienda crear una pendiente  $\geq 1,5\%$  en la superficie transitabile para limitar la formación de depósitos localizados de agua estancada. En caso de que estos depósitos de agua permanezcan en la superficie del azulejo, aun cuando la colocación se haya realizado correctamente, será necesario intervenir mecánicamente empleando un cepillo o un aspirador de líquidos. / Для наружных незащищенных полов Ragno рекомендует создавать уклон  $\geq 1,5\%$  на пешеходной поверхности для снижения образования локальных застоев воды. В случае, если застои воды образуются на плитке несмотря на правильную укладку, необходимо прибегать к использованию механических средств, таких как щетки или же аппараты для сбора жидкостей.

# Realstone\_Slate XT20

50x100 80x80



R648 Realstone\_Slate XT20 Mursk rettificado 80x80

# Realstone\_Slate XT20

50x100 80x80



Gruppo Bla UNI EN 14411\_G

gres fine porcellanato colorato in massa - rettificato monocalibro / colorbody fine porcelain stoneware - rectified monocaliber / durchgefärbtes feinsteinzeug - rektifiziert, in einem werkmaß / grès cérame fin coloré dans la masse - rectifié monocalibre / gres porcelánico fino coloreado en toda la masa - rettificado monocalibre / гомогенный мелкозернистый керамогранит - ректифицированный монокалиберный

superfici / surfaces / finitions / oberflächen / superficies / поверхности: outdoor



H

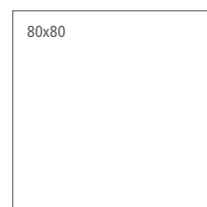

R643 Slate XT20 Shell rettificato



R63T Slate XT20 Shell rettificato



H

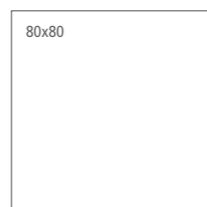

R645 Slate XT20 Iron rettificato



R63V Slate XT20 Iron rettificato



H

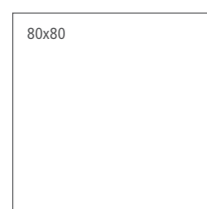

R648 Slate XT20 Musk rettificato



R63W Slate XT20 Musk rettificato

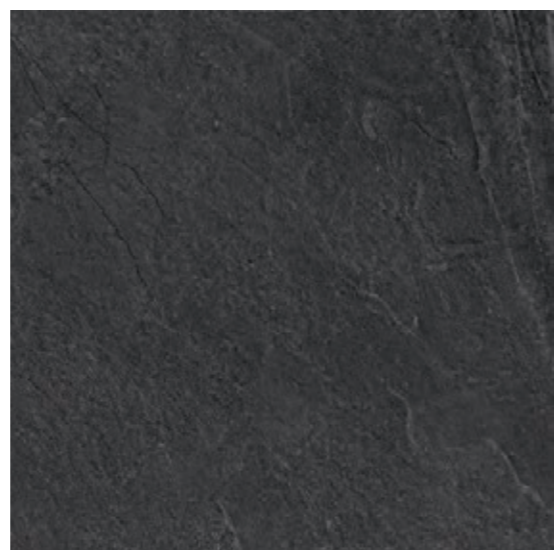

H

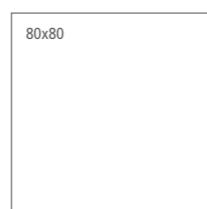

R64A Slate XT20 Black rettificato



R63X Slate XT20 Black rettificato

## tech info

\*

Assemblato (pag. 592) / Two-piece L-tile (page 592) / Randstein zweiteilig (S. 592) / Assemblé (page 592) / Montado (pág. 592) / Собранный (стр. 592)



Apprezzabili differenze nell'aspetto di superficie e grafica all'interno della stessa produzione. / Clearly distinguishable differences in texture and pattern within the same production run. / Auffällige Unterschiede in Aussehen und Struktur innerhalb der gleichen Produktionscharge. / Différences visibles au niveau de l'aspect et de la fantaisie entre les carreaux du même lot de production. / Diferencias visibles en el aspecto de la superficie y los motivos dentro de un mismo lote de producción. / Заметные отличия вида поверхности и графики в одной и той же партии.



Vedi Appendice pag. 585  
See Appendix page 585  
Siehe Anhang S. 585  
Voir Annexe page 585  
Véase la pág. 585 del Apéndice  
Смотри приложение на стр. 585

## imballi / packaging / verpackungen / emballages / embalajes / упаковки

Scatole / Box / Karton / Boite / Caja / Коробки	Pallet / Pallet / Palette / Palette / Поддон	mm
M <sup>2</sup>	KG	

## fondi / plain tiles / grundfliesen / fonds / fondos / фоновая плитка

50x100	80x80	rettificato	1	0,50	23,50	50	25,00	1175	20
50x100	80x80	rettificato	1	0,64	30,50	45	28,80	1373,00	20

## pezzi speciali / trims / spezialteile / pièces spéciales / piezas especiales / специальные изделия

	GRADONE* STEP TILE* 40x80	GRADONE* STEP TILE* 40x80	GRADONE* STEP TILE* 40x80	GRADONE* STEP TILE* 40x80	GRADONE* STEP TILE* 40x100	GRADONE* STEP TILE* 40x100	GRADONE* STEP TILE* 40x100	GRADONE* STEP TILE* 40x100		
LAVORAZIONE LATI TAGLIO + ASSEMBLAGGIO EDGES PRODUCED BY CUTTING + ASSEMBLY	SOLO SU LATO LUNGO ON LONG SIDE ONLY	LATO LUNGO + SX LONG SIDE + L	LATO LUNGO + DX LONG SIDE + R	LATO LUNGO + DX + SX LONG SIDE + R + L	SOLO SU LATO LUNGO ON LONG SIDE ONLY	LATO LUNGO + SX LONG SIDE + L	LATO LUNGO + DX LONG SIDE + R	LATO LUNGO + DX + SX LONG SIDE + R + L		
Slate XT20 Shell	R699	R69K	R69Z	R6AK	R64R	R650	R65C	R65P		
Slate XT20 Iron	R69C	R69M	R6AC	R6AM	R64T	R652	R65F	R65R		
Slate XT20 Musk	R69E	R69Q	R6AE	R6AP	R64V	R654	R65H	R65T		
Slate XT20 Black	R69G	R69S	R6AG	R6AR	R64X	R658	R65K	R65V		
	ALZATA RISER TILE 20x80	ALZATA RISER TILE 20x80	ALZATA RISER TILE 20x80	ALZATA RISER TILE 20x100	ALZATA RISER TILE 20x100	ALZATA RISER TILE 20x100	COPRI MURETTO COPING TILE 40x80	COPRI MURETTO COPING TILE 40x80	COPRI MURETTO COPING TILE 40x100	COPRI MURETTO COPING TILE 40x100
LAVORAZIONE LATI EDGE SHAPING	NESSUN LATO LAVORATO NO SHAPED EDGES	ENTRAMBI I LATI CORTI BOTH SHORT SIDES	DX/SX RIBALTABILE RL REVERSIBLE	NESSUN LATO LAVORATO NO SHAPED EDGES	ENTRAMBI I LATI CORTI BOTH SHORT SIDES	DX/SX RIBALTABILE RL REVERSIBLE	SU 2 LATI LUNGHI ON THE 2 LONG SIDES	SU 3 LATI ON 3 SIDES	SU 2 LATI LUNGHI ON THE 2 LONG SIDES	SU 3 LATI ON 3 SIDES
Slate XT20 Shell	R6AU	R6CD	R6CN	R667	R66L	R66V	R6CX	R67X	R67G	
Slate XT20 Iron	R6AW	R6CF	R6CQ	R669	R66N	R66X	R6CZ	R6DK	R678	R67J
Slate XT20 Musk	R6AY	R6CH	R6CS	R66C	R66Q	R66Z	R6DC	R6DM	R67A	R67L
Slate XT20 Black	R6CO	R6CK	R6CU	R66E	R66S	R671	R6DE	R6DP	R67D	R67N
	ELEMENTO ELLE* L-EDGING TILE* 15x80x4	ELEMENTO ELLE* L-EDGING TILE* 15x100x4	BORDO U* U-EDGING TILE* 15x80x15	CORDOLO L* L-KERB TILE* 15x20x80	CANALINA* GUTTER TILE* 15x80x8	GRIGLIA GRID TILE 15x80	BORDO U* U-EDGING TILE* 15x50x15	CORDOLO L* L-KERB TILE* 15x20x50	CANALINA* GUTTER TILE* 15x50x8	GRIGLIA GRID TILE 15x50
LAVORAZIONE ROMPIGOCCIA NON-DROP EDGE										
Slate XT20 Shell	R68Y	R64E	R6EC	R6DS	R6EX	R6EN	R681	R67R	R68C	R68P
Slate XT20 Iron	R690	R64H	R6EE	R6DU	R6F9	R6EQ	R683	R67U	R68E	R68R
Slate XT20 Musk	R692	R64L	R6EH	R6DW	R6FC	R6ES	R685	R67V	R68H	R68T
Slate XT20 Black	R695	R64N	R6EK	R6DY	R6FE	R6EU	R688	R67Y	R68K	R68V

Tutti i pezzi speciali sono su richiesta e sono coordinabili ai fondi rettificati. Gli imballi vengono calcolati sulla base del quantitativo ordinato.

All special pieces are supplied to order and can be matched with the rectified plain tiles. Packaging is calculated on the basis of the quantity ordered.

Alle Formteile sind auf Anfrage erhältlich und mit den rektifizierten Grundfliesen kombinierbar. Die Verpackung wird auf der Grundlage der Bestellmenge berechnet.

Toutes les pièces spéciales sont fabriquées sur demande et coordonnables aux fonds rectifiés. Les emballages sont calculés en fonction de la quantité commandée.

Todas las piezas especiales se entregan bajo pedido y se pueden coordinar con los fondos rectificados. Los embalajes se calculan según las cantidades encargadas en los pedidos.

Все специальные изделия производятся на заказ и сочетаются с обрешеточной плиткой. Упаковки рассчитываются на основе заказанного количества.

Per le pavimentazioni esterne non protette, Ragno consiglia di creare una pendenza  $\geq 1,5\%$  sulla superficie calpestabile allo scopo di limitare il formarsi di ristagni d'acqua localizzati. Nel caso in cui questi ristagni permangano sulla superficie delle piastrelle nonostante una posa a regola d'arte, è necessario intervenire meccanicamente con l'utilizzo di scope o aspira-liquidi. / For unprotected outdoor pavings, Ragno recommends the creation of a gradient of  $\geq 1.5\%$  on the finished surface, to prevent the formation of patches of standing water. In the event that standing water persists on the surface of the tiles in spite of correct installation, it must be removed mechanically with the aid of brooms or wet-and-dry vacuum cleaners. / Zur Unterbindung von punktueller Stauwasserbildung bei Belägen in ungeschützten Außenbereichen, empfiehlt die Ragno die Ausbildung eines Gefälles  $\geq 1,5\%$  auf der Trittlfläche. Sollte trotz fachgerechter Verlegung Stauwasser auf der Fliesenoberfläche zurückbleiben, ist dessen mechanische Entfernung mit Hilfe eines Besens oder Nasssaugers erforderlich. / Pour des sols extérieurs non protégés, Ragno conseille de créer une inclinaison  $\geq 1,5\%$  sur la surface de piétement en vue de limiter la stagnation localisée de l'eau. Si, malgré une pose dans les règles de l'art, cette stagnation devait persister à la surface des carreaux, une intervention mécanique, au moyen de balais et d'aspirateurs de liquides, est alors nécessaire. / En el caso de pavimentaciones exteriores no protegidas, Ragno recomienda crear una pendiente  $\geq 1,5\%$  en la superficie transitable para limitar la formación de depósitos localizados de agua estancada. En caso de que estos depósitos de agua permanezcan en la superficie del azulejo, aun cuando la colocación se haya realizado correctamente, será necesario intervenir mecánicamente empleando un cepillo o un aspirador de líquidos. / Для наружных незащищенных полов Ragno рекомендует создавать уклон  $\geq 1,5\%$  на пешеходной поверхности для снижения образования локальных застоев воды. В случае, если застои воды образуются на плитке несмотря на правильную укладку, необходимо прибегать к использованию механических средств, таких как щетки или же аппараты для сбора жидкостей.



# Realstone\_Rain XT20

50x100



RAWS Rain XT20 Almond rettificato 50X100  
RAZN Rain Almond griglia 15x50  
RAZR Rain Almond canalina 15x80x8  
RAYK Rain elemento elle 15x100x4

XT20

# Realstone\_Rain XT20

50x100

Gruppo Bla UNI EN 14411\_G

gres fine porcellanato colorato in massa - rettificato monocalibro / colorbody fine porcelain stoneware - rectified monocaliber / durchgefärbtes feinsteinzeug - rektifiziert, in einem werkmaß / grès cérame fin coloré dans la masse - rectifié monocalibre / gres porcelánico fino coloreado en toda la masa - rectificado monocalibre / гомогенный мелкозернистый керамогранит - ректифицированный монокалиберный



superfici / surfaces / finitions / oberflächen / superficies / поверхности: outdoor



RAWS Rain XT20 Almond rettificato  
50x100

H



RAWT Rain XT20 Greige rettificato  
50x100

H



RAWU Rain XT20 Taupe rettificato  
50x100

H

## tech info

\*

Assemblato (pag. 592) / Two-piece L-tile (page 592) / Randstein zweiteilig (S. 592) / Assemblé (page 592) / Montado (pág. 592) / Собранный (стр. 592)



Apprezzabili differenze nell'aspetto di superficie e grafica all'interno della stessa produzione. / Clearly distinguishable differences in texture and pattern within the same production run. / Auffällige Unterschiede in Aussehen und Struktur innerhalb der gleichen Produktionscharge. / Différences visibles au niveau de l'aspect et de la fantaisie entre les carreaux du même lot de production. / Diferencias visibles en el aspecto de la superficie y los motivos dentro de un mismo lote de producción. / Заметные отличия вида поверхности и графики в одной и той же партии.



Vedi Appendice pag. 585  
See Appendix page 585  
Siehe Anhang S. 585  
Voir Annexe page 585  
Véase la pág. 585 del Apéndice  
Смотри приложение на стр. 585

imballi / packaging / verpackungen / emballages / embalajes / упаковки

Scatole / Box / Karton / Boite / Caja / Коробки

Pallet / Pallet / Palette / Palette / Pallet / Поддон



fondi / plain tiles / grundfliesen / fonds / fondos / фоновая плитка

50x100	1	0,50	23,50	50	25,00	1175,00	20
--------	---	------	-------	----	-------	---------	----

## pezzi speciali / trims / spezialteile / pièces spéciales / piezas especiales / специальные изделия

	GRADONE* STEP TILE* 40x100	GRADONE* STEP TILE* 40x100	GRADONE* STEP TILE* 40x100	GRADONE* STEP TILE* 40x100	ALZATA RISER TILE 20x100	ALZATA RISER TILE 20x100	ALZATA RISER TILE 20x100
LAVORAZIONE LATI TAGLIO + ASSEMBLAGGIO EDGES PRODUCED BY CUTTING + ASSEMBLY	SOLO SU LATO LUNGO ON LONG SIDE ONLY	LATO LUNGO + SX LONG SIDE + L	LATO LUNGO + DX LONG SIDE + R	LATO LUNGO + DX + SX LONG SIDE + R + L	NESSUN LATO LAVORATO NO SHAPED EDGES	ENTRAMBI I LATI CORTI BOTH SHORT SIDES	DX/SX RIBALTABILE RL/REVERSIBLE
Rain XT20 Almond	RAYN	RAYR	RAYU	RAYX	RAZO	RAZ3	RAZ6
Rain XT20 Greige	RAYP	RAYS	RAYV	RAYY	RAZ1	RAZ4	RAZ7
Rain XT20 Taupe	RAYQ	RAYT	RAYW	RAYZ	RAZ2	RAZ5	RAZ8

	COPRI MURETTO COPING TILE 40x100	COPRI MURETTO COPING TILE 40x100	ELEMENTO ELLE* L-EDGING TILE* 15x100x4	BORDO U* U-EDGING TILE* 15x50x15	CORDOLO L* L-KERB TILE* 15x50x20	CANALINA* GUTTER TILE* 15x50x8	GRIGLIA GRID TILE 15x50
LAVORAZIONE ROMPIGOCCIA NON-DRIP EDGE	SU 2 LATI LUNGHI ON THE 2 LONG SIDES	SU 3 LATI ON 3 SIDES					
Rain XT20 Almond	RAZ9	RAZD	RAYK	RAZK	RAZG	RAZR	RAZN
Rain XT20 Greige	RAZA	RAZE	RAYL	RAZL	RAZH	RAZS	RAZP
Rain XT20 Taupe	RAZC	RAZF	RAYM	RAZM	RAZJ	RAZT	RAZQ

Tutti i pezzi speciali sono su richiesta e sono coordinabili ai fondi rettificati. Gli imballi vengono calcolati sulla base del quantitativo ordinato.

All special pieces are supplied to order and can be matched with the rectified plain tiles. Packaging is calculated on the basis of the quantity ordered.

Alle Formteile sind auf Anfrage erhältlich und mit den rektifizierten Grundfliesen kombinierbar. Die Verpackung wird auf der Grundlage der Bestellmenge berechnet.

Toutes les pièces spéciales sont fabriquées sur demande et coordonnables aux fonds rectifiés. Les emballages sont calculés en fonction de la quantité commandée.

Todas las piezas especiales se entregan bajo pedido y se pueden coordinar con los fondos rectificados. Los embalajes se calculan según las cantidades encargadas en los pedidos.

Все специальные изделия производятся на заказ и сочетаются с обрешетной фоновой плиткой. Упаковки рассчитываются на основе заказанного количества.

Per le pavimentazioni esterne non protette, Ragno consiglia di creare una pendenza  $\geq 1,5\%$  sulla superficie calpestabile allo scopo di limitare il formarsi di ristagni d'acqua localizzati. Nel caso in cui questi ristagni permangano sulla superficie delle piastrelle nonostante una posa a regola d'arte, è necessario intervenire meccanicamente con l'utilizzo di scope o aspira-liquidi. / For unprotected outdoor pavings, Ragno recommends the creation of a gradient of  $\geq 1.5\%$  on the finished surface, to prevent the formation of patches of standing water. In the event that standing water persists on the surface of the tiles in spite of correct installation, it must be removed mechanically with the aid of brooms or wet-and-dry vacuum cleaners. / Zur Unterbindung von punktueller Stauwasserbildung bei Belägen in ungeschützten Außenbereichen, empfiehlt die Ragno die Ausbildung eines Gefälles  $\geq 1,5\%$  auf der Trittläche. Sollte trotz fachgerechter Verlegung Stauwasser auf der Fliesenoberfläche zurückbleiben, ist dessen mechanische Entfernung mit Hilfe eines Besens oder Nasssaugers erforderlich. / Pour des sols extérieurs non protégés, Ragno conseille de créer une inclinaison  $\geq 1,5\%$  sur la surface de piétinement en vue de limiter la stagnation localisée de l'eau. Si, malgré une pose dans les règles de l'art, cette stagnation devait persister à la surface des carreaux, une intervention mécanique, au moyen de balais et d'aspirateurs de liquides, est alors nécessaire. / En el caso de pavimentaciones exteriores no protegidas, Ragno recomienda crear una pendiente  $\geq 1,5\%$  en la superficie transitable para limitar la formación de depósitos localizados de agua estancada. En caso de que estos depósitos de agua permanezcan en la superficie del azulejo, aun cuando la colocación se haya realizado correctamente, será necesario intervenir mecánicamente empleando un cepillo o un aspirador de líquidos. / Для наружных незащищенных полов Ragno рекомендует создавать уклон  $\geq 1,5\%$  на пешеходной поверхности для снижения образования локальных застоев воды. В случае, если застои воды образуются на плитке несмотря на правильную укладку, необходимо прибегать к использованию механических средств, таких как щетки или же аппараты для сбора жидкостей.

# Realstone\_Cardoso XT20

50x100



R06W Cardoso XT20 Grigio rettificato 50x100

XT20

# Realstone\_Cardoso XT20

50x100

Gruppo Bla UNI EN 14411\_G

gres fine porcellanato colorato in massa - rettificato monocoloro / colorbody fine porcelain stoneware - rectified monocolor / durchgefärbtes feinsteinzeug - rektifiziert, in einem werkmaß / grès cérame fin coloré dans la masse - rectifié monocolor / gres porcelánico fino coloreado en toda la masa - rectificado monocolor / гомогенный мелкозернистый керамогранит - ректифицированный монокалиберный



superfici / surfaces / finitions / oberflächen / superficies / поверхности: outdoor



**R06W** Cardoso XT20 Grigio rettificato  
50x100

H

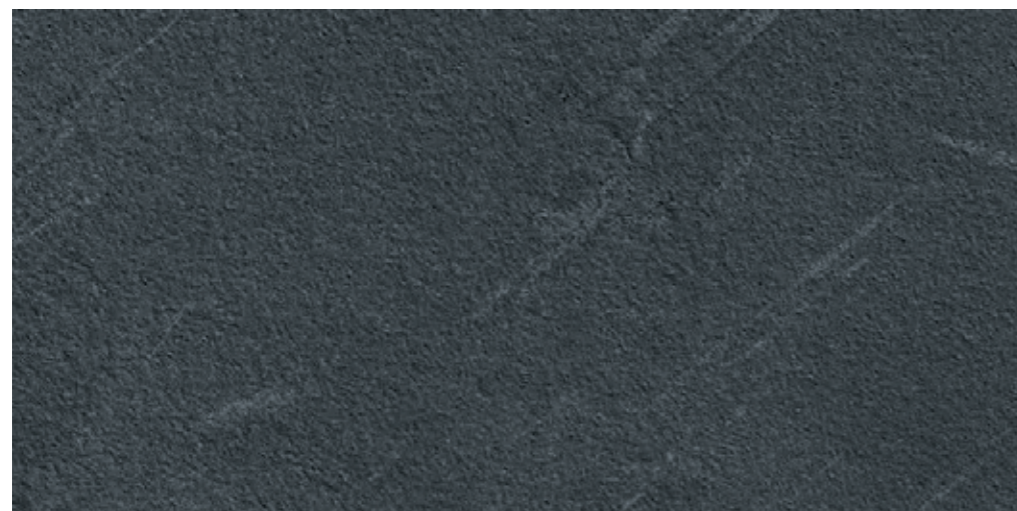

**R18F** Cardoso XT20 Antracite rettificato  
50x100

H



**R18G** Cardoso XT20 Silver rettificato  
50x100

H

## tech info

\*

Assemblato (pag. 592) / Two-piece L-tile (page 592) / Randstein zweiteilig (S. 592) / Assemblé (page 592) / Montado (pág. 592) / Собранный (стр. 592)



Vedi Appendice pag. 585  
See Appendix page 585  
Siehe Anhang S. 585  
Voir Annexe page 585  
Véase la pág. 585 del Apéndice  
Смотри приложение на стр. 585



Apprezzabili differenze nell'aspetto di superficie e grafica all'interno della stessa produzione. / Clearly distinguishable differences in texture and pattern within the same production run. / Auffällige Unterschiede in Aussehen und Struktur innerhalb der gleichen Produktionscharge. / Différences visibles au niveau de l'aspect et de la fantaisie entre les carreaux du même lot de production. / Diferencias visibles en el aspecto de la superficie y los motivos dentro de un mismo lote de producción. / Заметные отличия вида поверхности и графики в одной и той же партии.

imballi / packaging / verpackungen / emballages / embalajes / упаковки

Scatole / Box / Karton / Boite / Caja / Коробки Pallet / Pallet / Palette / Palette / Pallet / Поддон



fondi / plain tiles / grundfliesen / fonds / fondos / фоновая плитка  
50x100 1 0,5 23,50 50 25,00 1175,00 20

## pezzi speciali / trims / spezialteile / pièces spéciales / piezas especiales / специальные изделия

	GRADONE* STEP TILE* 40x100	GRADONE* STEP TILE* 40x100	GRADONE* STEP TILE* 40x100	GRADONE* STEP TILE* 40x100	ALZATA RISER TILE 20x100	ALZATA RISER TILE 20x100	ALZATA RISER TILE 20x100
LAVORAZIONE LATI TAGLIO + ASSEMBLAGGIO EDGES PRODUCED BY CUTTING + ASSEMBLY	SOLO SU LATO LUNGO ON LONG SIDE ONLY	LATO LUNGO + SX LONG SIDE + L	LATO LUNGO + DX LONG SIDE + R	LATO LUNGO + DX + SX LONG SIDE + R + L	NESSUN LATO LAVORATO NO SHAPED EDGES	ENTRAMBI I LATI CORTI BOTH SHORT SIDES	DX/SX RIBALTABILE RL REVERSIBLE
Cardoso XT20 Grigio	R09M	R09N	R09P	R09Q	R09R	R09S	R09T
Cardoso XT20 Antracite	R18K	R18M	R18P	R18R	R18T	R18V	R18X
Cardoso XT20 Silver	R18L	R18N	R18Q	R18S	R18U	R18W	R18Y

	COPRI MURETTO COPING TILE 40x100	COPRI MURETTO COPING TILE 40x100	ELEMENTO ELLE* L-EDGING TILE* 15x100x4	BORDO U* U-EDGING TILE* 15x50x15	CORDOLO L* L-KERB TILE* 15x50x20	CANALINA* GUTTER TILE* 15x50x8	GRIGLIA GRID TILE 15x50
LAVORAZIONE ROMPIGOCCIA NON-DRIP EDGE	SU 2 LATI LUNGH ON THE 2 LONG SIDES	SU 3 LATI ON 3 SIDES					
Cardoso XT20 Grigio	R09U	R09V	R09L	R09X	R09W	R09Y	R09Z
Cardoso XT20 Antracite	R18Z	R191	R18H	R19C	R193	R19G	R19E
Cardoso XT20 Silver	R190	R192	R18J	R19D	R19A	R19H	R19F

Tutti i pezzi speciali sono su richiesta e sono coordinabili ai fondi rettificati. Gli imballi vengono calcolati sulla base del quantitativo ordinato.

All special pieces are supplied to order and can be matched with the rectified plain tiles. Packaging is calculated on the basis of the quantity ordered.

Alle Formteile sind auf Anfrage erhältlich und mit den rektifizierten Grundfliesen kombinierbar. Die Verpackung wird auf der Grundlage der Bestellmenge berechnet.

Toutes les pièces spéciales sont fabriquées sur demande et coordonnables aux fonds rectifiés. Les emballages sont calculés en fonction de la quantité commandée.

Todas las piezas especiales se entregan bajo pedido y se pueden coordinar con los fondos rectificados. Los embalajes se calculan según las cantidades encargadas en los pedidos.

Все специальные изделия производятся на заказ и сочетаются с обрезной фоновой плиткой. Упаковки рассчитываются на основе заказанного количества.

Per le pavimentazioni esterne non protette, Ragno consiglia di creare una pendenza  $\geq 1,5\%$  sulla superficie calpestabile allo scopo di limitare il formarsi di ristagni d'acqua localizzati. Nel caso in cui questi ristagni permangano sulla superficie delle piastrelle nonostante una posa a regola d'arte, è necessario intervenire meccanicamente con l'utilizzo di scope o aspira-liquidi. / For unprotected outdoor pavings, Ragno recommends the creation of a gradient of  $\geq 1.5\%$  on the finished surface, to prevent the formation of patches of standing water. In the event that standing water persists on the surface of the tiles in spite of correct installation, it must be removed mechanically with the aid of brooms or wet-and-dry vacuum cleaners. / Zur Unterbindung von punktueller Stauwasserbildung bei Belägen in ungeschützten Außenbereichen, empfiehlt die Ragno die Ausbildung eines Gefälles  $\geq 1,5\%$  auf der Trittläche. Sollte trotz fachgerechter Verlegung Stauwasser auf der Fliesenoberfläche zurückbleiben, ist dessen mechanische Entfernung mit Hilfe eines Besens oder Nasssaugers erforderlich. / Pour des sols extérieurs non protégés, Ragno conseille de créer une inclinaison  $\geq 1,5\%$  sur la surface de piétinement en vue de limiter la stagnation localisée de l'eau. Si, malgré une pose dans les règles de l'art, cette stagnation devait persister à la surface des carreaux, une intervention mécanique, au moyen de balais et d'aspirateurs de liquides, est alors nécessaire. / En el caso de pavimentaciones exteriores no protegidas, Ragno recomienda crear una pendiente  $\geq 1,5\%$  en la superficie transitable para limitar la formación de depósitos localizados de agua estancada. En caso de que estos depósitos de agua permanezcan en la superficie del azulejo, aun cuando la colocación se haya realizado correctamente, será necesario intervenir mecánicamente empleando un cepillo o un aspirador de líquidos. / Для наружных незащищенных полов Ragno рекомендует создавать уклон  $\geq 1,5\%$  на пешеходной поверхности для снижения образования локальных застоев воды. В случае, если застои воды образуются на плитке несмотря на правильную укладку, необходимо прибегать к использованию механических средств, таких как щетки или же аппараты для сбора жидкостей.

# Realstone\_Jerusalem XT20

50x100



R06X Jerusalem XT20 Avorio rettificato 50x100

# Realstone\_Jerusalem XT20

50x100

Gruppo Bla UNI EN 14411\_G

gres fine porcellanato colorato in massa - rettificato monocalibro / colorbody fine porcelain stoneware - rectified monocaliber / durchgefärbtes feinsteinzeug - rektifiziert, in einem werkmaß / grès cérame fin coloré dans la masse - rectifié monocalibre / gres porcelánico fino coloreado en toda la masa - rectificado monocalibre / гомогенный мелкозернистый керамогранит - ректифицированный монокалиберный



superfici / surfaces / finitions / oberflächen / superficies / поверхности: outdoor



R06X Jerusalem XT20 Avorio rettificato 50x100

H



R06Y Jerusalem XT20 Noce rettificato 50x100

H

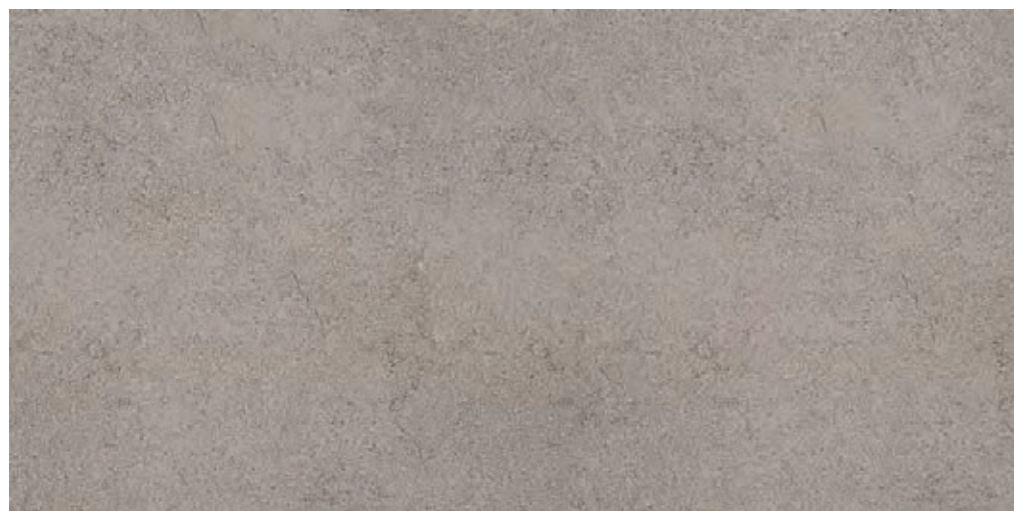

R12E Jerusalem XT20 Grigio rettificato 50x100

H

## tech info

\*

Assemblato (pag. 592) / Two-piece L-tile (page 592) / Randstein zweiteilig (S. 592) / Assemblé (page 592) / Montado (pág. 592) / Собранный (стр. 592)



Vedi Appendice pag. 585  
See Appendix page 585  
Siehe Anhang S. 585  
Voir Annexe page 585  
Véase la pág. 585 del Apéndice  
Смотри приложение на стр. 585



Apprezzabili differenze nell'aspetto di superficie e grafica all'interno della stessa produzione. / Clearly distinguishable differences in texture and pattern within the same production run. / Auffällige Unterschiede in Aussehen und Struktur innerhalb der gleichen Produktionscharge. / Différences visibles au niveau de l'aspect et de la fantaisie entre les carreaux du même lot de production. / Diferencias visibles en el aspecto de la superficie y los motivos dentro de un mismo lote de producción. / Заметные отличия вида поверхности и графики в одной и той же партии.

imballi / packaging / verpackungen / emballages / embalajes / упаковки

Scatole / Box / Karton / Boite / Caja / Коробки Pallet / Pallet / Palette / Palette / Pallet / Поддон



fondi / plain tiles / grundfliesen / fonds / fondos / фоновая плитка

50x100	1	0,50	23,50	50	25,00	1175,00	20
--------	---	------	-------	----	-------	---------	----

## pezzi speciali / trims / spezialteile / pièces spéciales / piezas especiales / специальные изделия

	GRADONE* STEP TILE* 40x100	GRADONE* STEP TILE* 40x100	GRADONE* STEP TILE* 40x100	GRADONE* STEP TILE* 40x100	ALZATA RISER TILE 20x100	ALZATA RISER TILE 20x100	ALZATA RISER TILE 20x100
LAVORAZIONE LATI TAGLIO + ASSEMBLAGGIO EDGES PRODUCED BY CUTTING + ASSEMBLY	SOLO SU LATO LUNGO ON LONG SIDE ONLY	LATO LUNGO + SX LONG SIDE + L	LATO LUNGO + DX LONG SIDE + R	LATO LUNGO + DX + SX LONG SIDE + R + L	NESSUN LATO LAVORATO NO SHAPED EDGES	ENTRAMBI I LATI CORTI BOTH SHORT SIDES	DX/SX RIBALTABILE RL REVERSIBLE
Jerusalem XT20 Avorio	ROG0	ROG2	ROG4	ROJ4	RONN	RONQ	RON5
Jerusalem XT20 Noce	ROG1	ROG3	ROJ3	ROJ5	RONP	RONR	RONT
Jerusalem XT20 Grigio	R13F	R13G	R13H	R13J	R13K	R13L	R13M

	COPRI MURETTO COPING TILE 40x100	COPRI MURETTO COPING TILE 40x100	ELEMENTO ELLE* L-EDGING TILE* 15x100x4	BORDO U* U-EDGING TILE* 15x50x15	CORDOLO L* L-KERB TILE* 15x50x20	CANALINA* GUTTER TILE* 15x50x8	GRIGLIA GRID TILE 15x50
LAVORAZIONE ROMPIGOCCIA NON-DRIP EDGE	SU 2 LATI LUNGHI ON THE 2 LONG SIDES	SU 3 LATI ON 3 SIDES					
Jerusalem XT20 Avorio	RONX	RONZ	ROC9	RORD	ROQZ	R10A	R10E
Jerusalem XT20 Noce	RONY	ROPA	ROCE	ROTN	RORA	R10C	R10F
Jerusalem XT20 Grigio	R13N	R13P	R13E	R13R	R13Q	R12Y	R12W

Tutti i pezzi speciali sono su richiesta e sono coordinabili ai fondi rettificati. Gli imballi vengono calcolati sulla base del quantitativo ordinato.

All special pieces are supplied to order and can be matched with the rectified plain tiles. Packaging is calculated on the basis of the quantity ordered.

Alle Formteile sind auf Anfrage erhältlich und mit den rektifizierten Grundfliesen kombinierbar. Die Verpackung wird auf der Grundlage der Bestellmenge berechnet.

Toutes les pièces spéciales sont fabriquées sur demande et coordonnables aux fonds rectifiés. Les emballages sont calculés en fonction de la quantité commandée.

Todas las piezas especiales se entregan bajo pedido y se pueden coordinar con los fondos rectificados. Los embalajes se calculan según las cantidades encargadas en los pedidos.

Все специальные изделия производятся на заказ и сочетаются с обрезной фоновой плиткой. Упаковки рассчитываются на основе заказанного количества.

Per le pavimentazioni esterne non protette, Ragno consiglia di creare una pendenza  $\geq 1,5\%$  sulla superficie calpestabile allo scopo di limitare il formarsi di ristagni d'acqua localizzati. Nel caso in cui questi ristagni permangano sulla superficie delle piastrelle nonostante una posa a regola d'arte, è necessario intervenire meccanicamente con l'utilizzo di scope o aspira-liquidi. / For unprotected outdoor pavings, Ragno recommends the creation of a gradient of  $\geq 1,5\%$  on the finished surface, to prevent the formation of patches of standing water. In the event that standing water persists on the surface of the tiles in spite of correct installation, it must be removed mechanically with the aid of brooms or wet-and-dry vacuum cleaners. / Zur Unterbindung von punktueller Stauwasserbildung bei Belägen in ungeschützten Außenbereichen, empfiehlt die Ragno die Ausbildung eines Gefälles  $\geq 1,5\%$  auf der Trittläche. Sollte trotz fachgerechter Verlegung Stauwasser auf der Fliesenoberfläche zurückbleiben, ist dessen mechanische Entfernung mit Hilfe eines Besens oder Nasssaugers erforderlich. / Pour des sols extérieurs non protégés, Ragno conseille de créer une inclinaison  $\geq 1,5\%$  sur la surface de piétinement en vue de limiter la stagnation localisée de l'eau. Si, malgré une pose dans les règles de l'art, cette stagnation devait persister à la surface des carreaux, une intervention mécanique, au moyen de balais et d'aspirateurs de liquides, est alors nécessaire. / En el caso de pavimentaciones exteriores no protegidas, Ragno recomienda crear una pendiente  $\geq 1,5\%$  en la superficie transitable para limitar la formación de depósitos localizados de agua estancada. En caso de que estos depósitos de agua permanezcan en la superficie del azulejo, aun cuando la colocación se haya realizado correctamente, será necesario intervenir mecánicamente empleando un cepillo o un aspirador de líquidos. / Для наружных незащищенных полов Ragno рекомендует создавать уклон  $\geq 1,5\%$  на пешеходной поверхности для снижения образования локальных застоев воды. В случае, если застои воды образуются на плитке несмотря на правильную укладку, необходимо прибегать к использованию механических средств, таких как щетки или же аппараты для сбора жидкостей.

# Realstone\_Quarzite XT20

50x100



R07G Quarzite XT20 Grigio rettificato 50x100

# Realstone\_Quarzite XT20

50x100

Gruppo Bia UNI EN 14411\_G

gres fine porcellanato colorato in massa - rettificato monocalibro / colorbody fine porcelain stoneware - rectified monocaliber / durchgefärbtes feinsteinzeug - rektifiziert, in einem werkmaß / grès cérame fin coloré dans la masse - rectifié monocalibre / gres porcelánico fino coloreado en toda la masa - rectificado monocalibre / гомогенный мелкозернистый керамогранит - ректифицированный монокалиберный



superfici / surfaces / finitions / oberflächen / superficies / поверхности:  
outdoor



R07H Quarzite XT20 Bianco rettificato  
50x100

H



R07G Quarzite XT20 Grigio rettificato  
50x100

H

## tech info

\*

Assemblato (pag. 592) / Two-piece L-tile (page 592) / Randstein zweiteilig (S. 592) / Assemblé (page 592) / Montado (pág. 592) / Собранный (стр. 592)



Significativa variazione di aspetto superficiale, grafica e colore da piastrella a piastrella e all'interno della stessa piastrella. Si consiglia di visionare la gamma cromatica prima della selezione del materiale. / Significant variation in texture, pattern and colour from tile to tile within the same production run. The colour range should be viewed before selecting the material. / Bedeutende Variation in Aussehen, Struktur und Farbe von Fliese zu Fliese und in ein und derselben Fliese. Es wird empfohlen, das Farbsortiment vor der Auswahl des Materials zu prüfen. / Variation significative au niveau de l'aspect, de la fantaisie et de la couleur entre les carreaux et au sein d'un même carreau. Il est recommandé de consulter la gamme des couleurs avant de sélectionner le matériel. / Variación considerable en el aspecto superficial, los motivos y el color entre un azulejo y otro y dentro del propio azulejo. Es aconsejable visualizar la gama cromática antes de seleccionar el material. / Значительные отличия вида поверхности, графики и цвета у разных плиток и на одной и той же плитке. Перед отбором материала рекомендуется посмотреть цветовую гамму.



Vedi Appendice pag. 585  
See Appendix page 585  
Siehe Anhang S. 585  
Voir Annexe page 585  
Véase la pág. 585 del Apéndice  
Смотри приложение на стр. 585

imballi / packaging / verpackungen / emballages / embalajes / упаковки

Scatole / Box / Karton / Boite / Caja / Коробки Pallet / Pallet / Palette / Palette / Pallet / Поддон

	M <sup>2</sup>	KG		M <sup>2</sup>	KG	≠ mm
--	----------------	----	--	----------------	----	------

fondi / plain tiles / grundfliesen / fonds / fondos / фоновая плитка	1	0,50	23,50	50	25,00	1175,00	20
50x100							

## pezzi speciali / trims / spezialteile / pièces spéciales / piezas especiales / специальные изделия

	GRADONE* STEP TILE* 40x100	GRADONE* STEP TILE* 40x100	GRADONE* STEP TILE* 40x100	GRADONE* STEP TILE* 40x100	ALZATA RISER TILE 20x100	ALZATA RISER TILE 20x100	ALZATA RISER TILE 20x100
LAVORAZIONE LATI TAGLIO + ASSEMBLAGGIO EDGES PRODUCED BY CUTTING + ASSEMBLY	 SOLO SU LATO LUNGO ON LONG SIDE ONLY	 LATO LUNGO + SX LONG SIDE + L	 LATO LUNGO + DX LONG SIDE + R	 LATO LUNGO + DX + SX LONG SIDE + R + L	 NESSUN LATO LAVORATO NO SHAPED EDGES	 ENTRAMBI I LATI CORTI BOTH SHORT SIDES	 DX/SX RIBALTABILE RL REVERSIBLE
Quarzite XT20 Bianco	R10L	R10N	R10Q	R10S	R10U	R10Z	R11C
Quarzite XT20 Grigio	R10M	R10P	R10R	R10T	R10Y	R11A	R11D

	COPRI MURETTO COPING TILE 40x100	COPRI MURETTO COPING TILE 40x100	ELEMENTO ELLE* L-EDGING TILE* 15x100x4	BORDO U* U-EDGING TILE* 15x50x15	CORDOLO L* L-KERB TILE* 15x50x120	CANALINA* GUTTER TILE* 15x50x8	GRIGLIA GRID TILE 15x50
LAVORAZIONE ROMPIGOCCIA NON-DRIP EDGE	 SU 2 LATI LUNGHI ON THE 2 LONG SIDES	 SU 3 LATI ON 3 SIDES					
Quarzite XT20 Bianco	R11E	R11G	R10G	R11L	R11J	R11N	R10Q
Quarzite XT20 Grigio	R11F	R11H	R10J	R11M	R11K	R11P	R10R

Tutti i pezzi speciali sono su richiesta e sono coordinabili ai fondi rettificati. Gli imballi vengono calcolati sulla base del quantitativo ordinato.

All special pieces are supplied to order and can be matched with the rectified plain tiles. Packaging is calculated on the basis of the quantity ordered.

Alle Formteile sind auf Anfrage erhältlich und mit den rektifizierten Grundfliesen kombinierbar. Die Verpackung wird auf der Grundlage der Bestellmenge berechnet.

Toutes les pièces spéciales sont fabriquées sur demande et coordonnables aux fonds rectifiés. Les emballages sont calculés en fonction de la quantité commandée.

Todas las piezas especiales se entregan bajo pedido y se pueden coordinar con los fondos rectificados. Los embalajes se calculan según las cantidades encargadas en los pedidos.

Все специальные изделия производятся на заказ и сочетаются с обрезной фоновой плиткой. Упаковки рассчитываются на основе заказанного количества.

Per le pavimentazioni esterne non protette, Ragno consiglia di creare una pendenza  $\geq 1,5\%$  sulla superficie calpestabile allo scopo di limitare il formarsi di ristagni d'acqua localizzati. Nel caso in cui questi ristagni permangano sulla superficie delle piastrelle nonostante una posa a regola d'arte, è necessario intervenire meccanicamente con l'utilizzo di scope o aspira-liquidi. / For unprotected outdoor pavings, Ragno recommends the creation of a gradient of  $\geq 1.5\%$  on the finished surface, to prevent the formation of patches of standing water. In the event that standing water persists on the surface of the tiles in spite of correct installation, it must be removed mechanically with the aid of brooms or wet-and-dry vacuum cleaners. / Zur Unterbindung von punktueller Stauwasserbildung bei Belägen in ungeschützten Außenbereichen, empfiehlt die Ragno die Ausbildung eines Gefälles  $\geq 1,5\%$  auf der Trittfläche. Sollte trotz fachgerechter Verlegung Stauwasser auf der Fliesenoberfläche zurückbleiben, ist dessen mechanische Entfernung mit Hilfe eines Besens oder Nasssaugers erforderlich. / Pour des sols extérieurs non protégés, Ragno conseille de créer une inclinaison  $\geq 1,5\%$  sur la surface de piétinement en vue de limiter la stagnation localisée de l'eau. Si, malgré une pose dans les règles de l'art, cette stagnation devait persister à la surface des carreaux, une intervention mécanique, au moyen de balais et d'aspirateurs de liquides, est alors nécessaire. / En el caso de pavimentaciones exteriores no protegidas, Ragno recomienda crear una pendiente  $\geq 1,5\%$  en la superficie transitable para limitar la formación de depósitos localizados de agua estancada. En caso de que estos depósitos de agua permanezcan en la superficie del azulejo, aun cuando la colocación se haya realizado correctamente, será necesario intervenir mecánicamente empleando un cepillo o un aspirador de líquidos. / Для наружных незащищенных полов Ragno рекомендует создавать уклон  $\geq 1,5\%$  на пешеходной поверхности для снижения образования локальных застоев воды. В случае, если застои воды образуются на плитке несмотря на правильную укладку, необходимо прибегать к использованию механических средств, таких как щетки или же аппараты для сбора жидкостей.



# Stoneway\_Ardesia XT20

60x60



R5V3 Stoneway\_Ardesia XT20 - Belgio rettificato 60x60

# Stoneway\_Ardesia XT20

60x60

Gruppo Bla UNI EN 14411\_G

gres fine porcellanato colorato in massa - rettificato monocalibro / colorbody fine porcelain stoneware - rectified monocaliber / durchgefärbtes feinsteinzeug - rektifiziert, in einem werkmaß / grès cérame fin coloré dans la masse - rectifié monocalibre / gres porcelánico fino coloreado en toda la masa - rectificado monocalibre / гомогенный мелкозернистый керамогранит - ректифицированный монокалиберный



superfici / surfaces / finitions / oberflächen / superficies / поверхности: outdoor



R5UZ Stoneway\_Ardesia XT20 Grigio rettificato 60x60



R5V4 Stoneway\_Ardesia XT20 Antracite rettificato 60x60



R5V3 Stoneway\_Ardesia XT20 Beige rettificato 60x60



## tech info

\*\*

Assemblato (pag. 592) / Two-piece L-tile (page 592) / Randstein zweiteilig (S. 592) / Assembled (page 592) / Montado (pág. 592) / Собранная (стр. 592)



Significativa variazione di aspetto superficiale, grafica e colore da piastrella a piastrella e all'interno della stessa piastrella. Si consiglia di visionare la gamma cromatica prima della selezione del materiale. / Significant variation in texture, pattern and colour from tile to tile within the same production run. The colour range should be viewed before selecting the material. / Bedeutende Variation in Aussehen, Struktur und Farbe von Fliese zu Fliese und in ein und derselben Fliese. Es wird empfohlen, das Farbsortiment vor der Auswahl des Materials zu prüfen. / Variation significative au niveau de l'aspect, de la fantaisie et de la couleur entre les carreaux et au sein d'un même carreau. Il est recommandé de consulter la gamme des couleurs avant de sélectionner le matériel. / Variación considerable en el aspecto superficial, los motivos y el color entre un azulejo y otro y dentro del propio azulejo. Es aconsejable visualizar la gama cromática antes de seleccionar el material. / Значительные отличия вида поверхности, графики и цвета у разных плиток и на одной и той же плитке. Перед отбором материала рекомендуется посмотреть цветовую гамму.



Vedi Appendice pag. 585  
See Appendix page 585  
Siehe Anhang S. 585  
Voir Annexe page 585  
Véase la pág. 585 del Apéndice  
Смотри приложение на стр. 585

imballi / packaging / verpackungen / emballages / embalajes / упаковки

Scatole / Box / Karton / Boite / Caja / Коробки Pallet / Pallet / Palette / Palette / Поддон

	M <sup>2</sup>	KG		M <sup>2</sup>	KG	± mm
--	----------------	----	--	----------------	----	------

fondi / plain tiles / grundfliesen / fonds / fondos / фоновая плитка	2	0,72	33,78	32	23,04	1107,00	20
60x60							

pezzi speciali / trims / spezialteile / pièces spéciales / piezas especiales / специальные изделия

	GRADONE* STEP TILE* 30x60	GRADONE* STEP TILE* 30x60	GRADONE* STEP TILE* 30x60	GRADONE* STEP TILE* 30x60	ALZATA RISER TILE 20x60	ALZATA RISER TILE 20x60	ALZATA RISER TILE 20x60
LAVORAZIONE LATI TAGLIO + ASSEMBLAGGIO EDGES PRODUCED BY CUTTING + ASSEMBLY	SOLO SU LATO LUNGO ON LONG SIDE ONLY	LATO LUNGO + SX LONG SIDE + L	LATO LUNGO + DX LONG SIDE + R	LATO LUNGO + DX + SX LONG SIDE + R + L	NESSUN LATO LAVORATO NO SHAPED EDGES	ENTRAMBI I LATI CORTI BOTH SHORT SIDES	DX/SX RIBALTABILE RL REVERSIBLE
Stoneway_Ardesia XT20 Grigio	R5ZU	R5ZX	R600	R603	R60C	R60B	R60F
Stoneway_Ardesia XT20 Antracite	R5ZW	R5ZZ	R602	R605	R60A	R60E	R60H
Stoneway_Ardesia XT20 Beige	R5ZV	R5ZY	R601	R604	R609	R60D	R60G

	COPRI MURETTO COPING TILE 30x60	COPRI MURETTO COPING TILE 30x60	ELEMENTO ELLE* RETTIFICATO RECTIFIED L-EDGING TILE* 15x60x4	BORDO U* U-EDGING TILE* 15x60x15	CORDOLO L* L-KERB TILE* 15x20x60	CANALINA* GUTTER TILE* 15x60x8	GRIGLIA GRID TILE 15x60
LAVORAZIONE ROMPIGOCCIA NON-DRIP EDGE	SU 2 LATI LUNGI ON THE 2 LONG SIDES	SU 3 LATI ON 3 SIDES					
Stoneway_Ardesia XT20 Grigio	R60J	R60M	R5ZR	R60T	R60Q	R60Z	R60W
Stoneway_Ardesia XT20 Antracite	R60L	R60P	R5ZT	R60V	R60S	R611	R60Y
Stoneway_Ardesia XT20 Beige	R60K	R60N	R5ZS	R60U	R60R	R610	R60X

Tutti i pezzi speciali sono su richiesta e sono coordinabili ai fondi rettificati. Gli imballi vengono calcolati sulla base del quantitativo ordinato.

All special pieces are supplied to order and can be matched with the rectified plain tiles. Packaging is calculated on the basis of the quantity ordered.

Alle Formteile sind auf Anfrage erhältlich und mit den rektifizierten Grundfliesen kombinierbar. Die Verpackung wird auf der Grundlage der Bestellmenge berechnet.

Toutes les pièces spéciales sont fabriquées sur demande et coordonnables aux fonds rectifiés. Les emballages sont calculés en fonction de la quantité commandée.

Todas las piezas especiales se entregan bajo pedido y se pueden coordinar con los fondos rectificados. Los embalajes se calculan según las cantidades encargadas en los pedidos.

Все специальные изделия производятся на заказ и сочетаются с обрезной фоновой плиткой. Упаковки рассчитываются на основе заказанного количества.

Per le pavimentazioni esterne non protette, Ragno consiglia di creare una pendenza ≥ 1,5% sulla superficie calpestabile allo scopo di limitare il formarsi di ristagni d'acqua localizzati. Nel caso in cui questi ristagni permangano sulla superficie delle piastrelle nonostante una posa a regola d'arte, è necessario intervenire meccanicamente con l'utilizzo di scope o aspira-liquidi. / For unprotected outdoor pavings, Ragno recommends the creation of a gradient of ≥ 1.5% on the finished surface, to prevent the formation of patches of standing water. In the event that standing water persists on the surface of the tiles in spite of correct installation, it must be removed mechanically with the aid of brooms or wet-and-dry vacuum cleaners. / Zur Unterbindung von punktueller Stauwasserbildung bei Belägen in ungeschützten Außenbereichen, empfiehlt die Ragno die Ausbildung eines Gefälles ≥ 1,5% auf der Trittläche. Sollte trotz fachgerechter Verlegung Stauwasser auf der Fliesenoberfläche zurückbleiben, ist dessen mechanische Entfernung mit Hilfe eines Besens oder Nasssaugers erforderlich. / Pour des sols extérieurs non protégés, Ragno conseille de créer une inclinaison ≥ 1,5 % sur la surface de piétinement en vue de limiter la stagnation localisée de l'eau. Si, malgré une pose dans les règles de l'art, cette stagnation devait persister à la surface des carreaux, une intervention mécanique, au moyen de balais et d'aspirateurs de liquides, est alors nécessaire. / En el caso de pavimentaciones exteriores no protegidas, Ragno recomienda crear una pendiente ≥ 1,5% en la superficie transitable para limitar la formación de depósitos localizados de agua estancada. En caso de que estos depósitos de agua permanezcan en la superficie del azulejo, aun cuando la colocación se haya realizado correctamente, será necesario intervenir mecánicamente empleando un cepillo o un aspirador de líquidos. / Для наружных незащищённых полов Ragno рекомендует создавать уклон ≥ 1,5% на пешеходной поверхности для снижения образования локальных застоев воды. В случае, если застои воды образуются на плитке несмотря на правильную укладку, необходимо прибегать к использованию механических средств, таких как щетки или же аппараты для сбора жидкостей.

# Stoneway\_Barge Antica XT20

60x60

Gruppo Bla UNI EN 14411\_G

gres fine porcellanato colorato in massa / colorbody fine porcelain stoneware / durchgefärbtes feinsteinzeug in einem werkmaß / grès cérame fin coloré dans la masse / gres porcelánico fino coloreado en toda la masa / гомогенный мелкозернистый керамогранит

superfici / surfaces / finitions / oberflächen / superficies / поверхности:  
outdoor



R46L Stoneway\_Barge Grigio XT20 60x60



R46J Stoneway\_Barge Bianco XT20  
60x60



R46K Stoneway\_Barge Beige XT20  
60x60



R46L Stoneway\_Barge Grigio XT20  
60x60



Per le pavimentazioni esterne non protette, Ragno consiglia di creare una pendenza  $\geq 1,5\%$  sulla superficie calpestabile allo scopo di limitare il formarsi di ristagni d'acqua localizzati. Nel caso in cui questi ristagni permangano sulla superficie delle piastrelle nonostante una posa a regola d'arte, è necessario intervenire meccanicamente con l'utilizzo di scope o aspira-liquidi. / For unprotected outdoor pavings, Ragno recommends the creation of a gradient of  $\geq 1.5\%$  on the finished surface, to prevent the formation of patches of standing water. In the event that standing water persists on the surface of the tiles in spite of correct installation, it must be removed mechanically with the aid of brooms or wet-and-dry vacuum cleaners. / Zur Unterbindung von punktueller Stauwasserbildung bei Belägen in ungeschützten Außenbereichen, empfiehlt die Ragno die Ausbildung eines Gefälles  $\geq 1,5\%$  auf der Trittlfläche. Sollte trotz fachgerechter Verlegung Stauwasser auf der Fliesenoberfläche zurückbleiben, ist dessen mechanische Entfernung mit Hilfe eines Besens oder Nasssaugers erforderlich. / Pour des sols extérieurs non protégés, Ragno conseille de créer une inclinaison  $\geq 1,5\%$  sur la surface de piétinement en vue de limiter la stagnation localisée de l'eau. Si, malgré une pose dans les règles de l'art, cette stagnation devait persister à la surface des carreaux, une intervention mécanique, au moyen de balais et d'aspirateurs de liquides, est alors nécessaire. / En el caso de pavimentaciones exteriores no protegidas, Ragno recomienda crear una pendiente  $\geq 1,5\%$  en la superficie transitabile para limitar la formación de depósitos localizados de agua estancada. En caso de que estos depósitos de agua permanezcan en la superficie del azulejo, aun cuando la colocación se haya realizado correctamente, será necesario intervenir mecánicamente empleando un cepillo o un aspirador de líquidos. / Для наружных незащищенных полов Ragno рекомендует создавать уклон  $\geq 1,5\%$  на пешеходной поверхности для снижения образования локальных застоев воды. В случае, если застои воды образуются на плитке несмотря на правильную укладку, необходимо прибегать к использованию механических средств, таких как щетки или же аппараты для сбора жидкостей.

## tech info

\*

Assemblato (pag. 592)  
Two-piece L-tile (page 592)  
Randstein zweiteilig (S. 592)  
Assemblé (page 592)  
Montado (pág. 592)  
Собранная (стр. 592)



Variazioni irregolari da piastrella a piastrella. Una piastrella può differire totalmente nell'aspetto superficiale e colore da un'altra. Si consiglia di visionare la gamma cromatica prima della selezione del materiale. / Random differences from tile to tile. One tile may have totally different texture and colour from another. The colour range should be viewed before selecting the material. / Wesentliche Variationen von Fliese zu Fliese. Eine Fliese kann sich in Aussehen und Farbe komplett von einer anderen unterscheiden. Es wird empfohlen, das Farbsortiment vor der Auswahl des Materials zu prüfen. / Variations irrégulières entre les carreaux. L'aspect et la couleur peuvent être complètement différents d'un carreau à l'autre. Il est recommandé de consulter la gamme des couleurs avant de sélectionner le matériel. / Variaciones irregulares entre un azulejo y otro. Un azulejo puede ser completamente diferente de otro en el aspecto superficial y el color. Es aconsejable visualizar la gama cromática antes de seleccionar el material. / Неоднородные изменения на разных плитках. Каждая плитка может полностью отличаться по виду поверхности и цвету от другой. Перед отбором материала рекомендуется просмотреть цветовую гамму.

pezzi speciali / trims / spezialteile / pièces spéciales / piezas especiales / специальные изделия

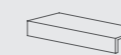

E. ELLE\*  
15x60

Stoneway_Barge XT20 Bianco	R46M
Stoneway_Barge XT20 Beige	R46N
Stoneway_Barge XT20 Grigio	R46P

imballi / packaging / verpackungen / emballages / embalajes / упаковки

Scatole / Box / Karton / Boite / Caja / Коробки  
Pallet / Pallet / Palette / Palette / Palette / Поддон



fondi / plain tiles / grundfliesen / fonds / fondos / фоновая плитка					
60x60	2	0,72	33,78	32	23,04 1107,00 20

pezzi speciali / trims / spezialteile / pièces spéciales / piezas especiales / специальные изделия					
15x60	E. ELLE	2	0,18	5,16	

# Stoneway\_Porfido XT20

60x60



R48S Stoneway\_Porfido Anthracite XT20 60x60

Gruppo Bla UNI EN 14411\_G

XT20

gres fine porcellanato colorato in massa / colorbody fine porcelain stoneware / durchgefärbtes feinsteinzeug in einem werkmaß / grès cérame fin coloré dans la masse / gres porcelánico fino coloreado en toda la masa / гомогенный мелкозернистый керамогранит

superfici / surfaces / finitions / oberflächen / superficies / поверхности:  
outdoor



R48P Stoneway\_Porfido Beige XT20  
60x60



R48R Stoneway\_Porfido Rust XT20  
60x60



R48S Stoneway\_Porfido Anthracite XT20  
60x60



Per le pavimentazioni esterne non protette, Ragno consiglia di creare una pendenza  $\geq 1,5\%$  sulla superficie calpestabile allo scopo di limitare il formarsi di ristagni d'acqua localizzati. Nel caso in cui questi ristagni permangano sulla superficie delle piastrelle nonostante una posa a regola d'arte, è necessario intervenire meccanicamente con l'utilizzo di scope o aspira-liquidi. / For unprotected outdoor pavings, Ragno recommends the creation of a gradient of  $\geq 1.5\%$  on the finished surface, to prevent the formation of patches of standing water. In the event that standing water persists on the surface of the tiles in spite of correct installation, it must be removed mechanically with the aid of brooms or wet-and-dry vacuum cleaners. / Zur Unterbindung von punktueller Stauwasserbildung bei Belägen in ungeschützten Außenbereichen, empfiehlt die Ragno die Ausbildung eines Gefälles  $\geq 1,5\%$  auf der Trittlfläche. Sollte trotz fachgerechter Verlegung Stauwasser auf der Fliesenoberfläche zurückbleiben, ist dessen mechanische Entfernung mit Hilfe eines Besens oder Nasssaugers erforderlich. / Pour des sols extérieurs non protégés, Ragno conseille de créer une inclinaison  $\geq 1,5\%$  sur la surface de piétinement en vue de limiter la stagnation localisée de l'eau. Si, malgré une pose dans les règles de l'art, cette stagnation devait persister à la surface des carreaux, une intervention mécanique, au moyen de balais et d'aspirateurs de liquides, est alors nécessaire. / En el caso de pavimentaciones exteriores no protegidas, Ragno recomienda crear una pendiente  $\geq 1,5\%$  en la superficie transitable para limitar la formación de depósitos localizados de agua estancada. En caso de que estos depósitos de agua permanezcan en la superficie del azulejo, aun cuando la colocación se haya realizado correctamente, será necesario intervenir mecánicamente empleando un cepillo o un aspirador de líquidos. / Для наружных незащищенных полов Ragno рекомендует создавать уклон  $\geq 1,5\%$  на пешеходной поверхности для снижения образования локальных застоев воды. В случае, если застои воды образуются на плитке несмотря на правильную укладку, необходимо прибегать к использованию механических средств, таких как щетки или же аппараты для сбора жидкостей.

## tech info

\*

Assemblato (pag. 592)  
Two-piece L-tile (page 592)  
Randstein zweiteilig (S. 592)  
Assemblé (page 592)  
Montado (pág. 592)  
Собранная (стр. 592)



Significativa variazione di aspetto superficiale, grafica e colore da piastrella a piastrella e all'interno della stessa piastrella. Si consiglia di visionare la gamma cromatica prima della selezione del materiale. / Significant variation in texture, pattern and colour from tile to tile within the same production run. The colour range should be viewed before selecting the material. / Bedeutende Variation in Aussehen, Struktur und Farbe von Fliese zu Fliese und in ein und derselben Fliese. Es wird empfohlen, das Farbsortiment vor der Auswahl des Materials zu prüfen. / Variation significative au niveau de l'aspect, de la fantaisie et de la couleur entre les carreaux et au sein d'un même carreau. Il est recommandé de consulter la gamme des couleurs avant de sélectionner le matériel. / Variación considerable en el aspecto superficial, los motivos y el color entre un azulejo y otro y dentro del propio azulejo. Es aconsejable visualizar la gama cromática antes de seleccionar el material. / Значительные отличия вида поверхности, графики и цвета у разных плиток и на одной и той же плитке. Перед отбором материала рекомендуется посмотреть цветовую гамму.

pezzi speciali / trims / spezialteile / pièces spéciales / piezas especiales / специальные изделия



E. ELLE\*  
15x60

Stoneway_Porfido Beige	R48V
Stoneway_Porfido Rust	R48X
Stoneway_Porfido Anthracite	R48Y

imballi / packaging / verpackungen / emballages / embalajes / упаковки

Scatole / Box / Karton / Boite / Caja / Коробки	Pallet / Pallet / Palette / Palette / Palette / Поддон
M <sup>2</sup> KG	M <sup>2</sup> KG  # mm

fondi / plain tiles / grundfliesen / fonds / fondos / фоновая плитка	60x60	2	0,72	33,65	32	23,04	1102,00	20
--	-------	---	------	-------	----	-------	---------	----

pezzi speciali / trims / spezialteile / pièces spéciales / piezas especiales / специальные изделия	15x60	E. ELLE	2	0,18	5,16
--	-------	---------	---	------	------

# Woodsense XT20

40x120 60x60



Gruppo Bia UNI EN 14411\_G

gres fine porcellanato colorato in massa - rettificato monocalibro / colorbody fine porcelain stoneware - rectified monocaliber / durchgefärbtes feinsteinzeug - rektifiziert, in einem werkmaß / grès cérame fin coloré dans la masse - rectifié monocalibre / gres porcelánico fino coloreado en toda la masa - rectificado monocalibre / гомогенный мелкозернистый керамогранит - ректифицированный монокалиберный

superfici / surfaces / finitions / oberflächen / superficies / поверхности: outdoor



H

R7L8 Woodsense XT20 Beige rettificato 40x120

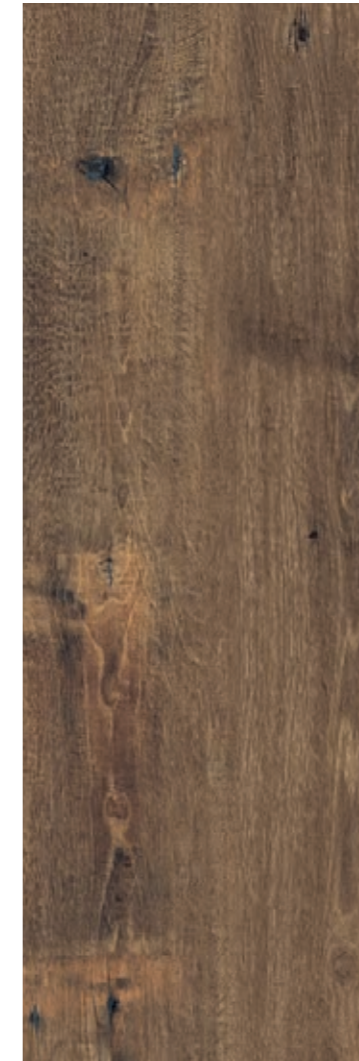

H

R7LA Woodsense XT20 Marrone rettificato 40x120



H

R7LC Woodsense XT20 Grigio rettificato 40x120

R7LC Woodsense XT20 Grigio rettificato 40x120  
 R7LH Woodsense XT20 Grigio rettificato 60x60  
 R82W Woodsense XT20 Grigio Alzata 20x60  
 R81W Woodsense XT20 Grigio Elemento Elle 15x60x4

XT20

# Woodsense XT20

40x120 60x60

Gruppo Bia UNI EN 14411\_G

gres fine porcellanato colorato in massa - rettificato monocallibro / colorbody fine porcelain stoneware - rectified monocallibro / durchgefärbtes feinsteinzeug - rektifiziert, in einem werkmaß / grès cérame fin coloré dans la masse - rectifié monocallibre / gres porcelánico fino coloreado en toda la masa - rectificado monocallibro / гомогенный мелкозернистый керамогранит - ректифицированный монокалиберный

superfici / surfaces / finitions / oberflächen / superficies / поверхности:  
outdoor



R7LF Woodsense XT20 Beige rettificato  
60x60



R7LG Woodsense XT20 Marrone rettificato  
60x60

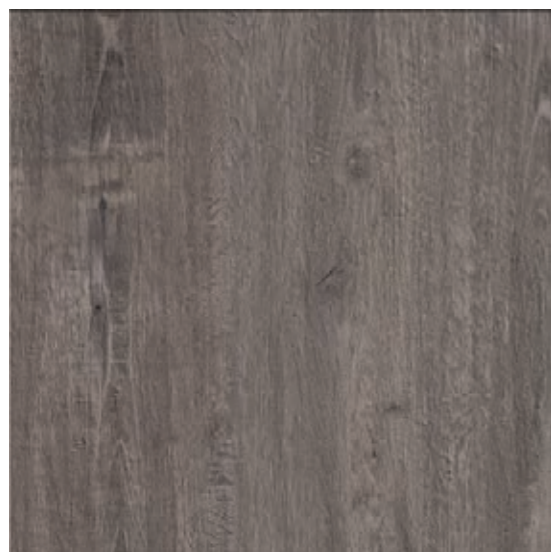

R7LH Woodsense XT20 Grigio rettificato  
60x60



## tech info

\*

Assemblato / Two-piece L-tile / Randstein zweiteilig / Assemblé / Montado / Собранный



Significativa variazione di aspetto superficiale, grafica e colore da piastrella a piastrella e all'interno della stessa piastrella. Si consiglia di visionare la gamma cromatica prima della selezione del materiale. / Significant variation in texture, pattern and colour from tile to tile within the same production run. The colour range should be viewed before selecting the material. / Bedeutende Variation in Aussehen, Struktur und Farbe von Fliese zu Fliese und in ein und derselben Fliese. Es wird empfohlen, das Farbsortiment vor der Auswahl des Materials zu prüfen. / Variation significative au niveau de l'aspect, de la fantaisie et de la couleur entre les carreaux et au sein d'un même carreau. Il est recommandé de consulter la gamme des couleurs avant de sélectionner le matériel. / Variación considerable en el aspecto superficial, los motivos y el color entre un azulejo y otro y dentro del propio azulejo. Es aconsejable visualizar la gama cromática antes de seleccionar el material. / Значительные отличия вида поверхности, графики и цвета у разных плиток и на одной и той же плитке. Перед отбором материала рекомендуется посмотреть цветовую гамму.

## imballi / packaging / verpackungen / emballages / embalajes / упаковки

Scatole / Box / Karton / Boite / Caja / Коробки	Pallet / Pallet / Palette / Palette / Pallet / Поддон	mm
M <sup>2</sup> KG	M <sup>2</sup> KG	

## fondi / plain tiles / grundfliesen / fonds / fondos / фоновая плитка

40x120	1	0,48	22,00	48	23,04	1055,90	20
60x60	2	0,72	34,26	32	23,04	1096,15	20

## pezzi speciali / trims / spezialteile / pièces spéciales / piezas especiales / специальные изделия

	GRADONE* STEP TILE* 30x60	GRADONE* STEP TILE* 30x60	GRADONE* STEP TILE* 30x60	GRADONE* STEP TILE* 30x60	GRADONE* STEP TILE* 40x120	GRADONE* STEP TILE* 40x120	GRADONE* STEP TILE* 40x120	GRADONE* STEP TILE* 40x120		
LAVORAZIONE LATI TAGLIO + ASSEMBLAGGIO EDGES PRODUCED BY CUTTING + ASSEMBLY	SOLO SU LATO LUNGO ON LONG SIDE ONLY	LATO LUNGO + SX LONG SIDE + L	LATO LUNGO + DX LONG SIDE + R	LATO LUNGO + DX + SX LONG SIDE + R + L	SOLO SU LATO LUNGO ON LONG SIDE ONLY	LATO LUNGO + SX LONG SIDE + L	LATO LUNGO + DX LONG SIDE + R	LATO LUNGO + DX + SX LONG SIDE + R + L		
Woodsense XT20 Beige	R81Y	R82G	R82L	R82Q	R88J	R88N	R88W	R891		
Woodsense XT20 Marrone	R822	R82H	R82M	R82R	R88K	R88P	R88X	R894		
Woodsense XT20 Grigio	R82A	R82J	R82N	R82S	R88L	R88Q	R88Y	R895		
	ALZATA RISER TILE 20x60	ALZATA RISER TILE 20x60	ALZATA RISER TILE 20x60	ALZATA RISER TILE 20x120	ALZATA RISER TILE 20x120	ALZATA RISER TILE 20x120	ALZATA RISER TILE 20x120	ALZATA RISER TILE 20x120		
LAVORAZIONE LATI EDGE SHAPING	NESSUN LATO LAVORATO NO SHAPED EDGES	ENTRABILI I LATI CORTI BOTH SHORT SIDES	DX/SX RIBALTABILE RL REVERSIBLE	NESSUN LATO LAVORATO NO SHAPED EDGES	ENTRABILI I LATI CORTI BOTH SHORT SIDES	DX/SX RIBALTABILE RL REVERSIBLE	ENTRABILI I LATI CORTI BOTH SHORT SIDES	DX/SX RIBALTABILE RL REVERSIBLE		
Woodsense XT20 Beige	R82U	R83R	R84K	R899	R89E	R8AS				
Woodsense XT20 Marrone	R82V	R83T	R84L	R89A	R89F	R8AT				
Woodsense XT20 Grigio	R82W	R83U	R84M	R89C	R89G	R8AW				
	COPRI MURETTO COPING TILE 30x60	COPRI MURETTO COPING TILE 30x60	COPRI MURETTO COPING TILE 40x120	COPRI MURETTO COPING TILE 40x120	ELEMENTO ELLE* L-EDGING TILE* 15x60x4	ELEMENTO ELLE* L-EDGING TILE* 15x120x4	BORDO U* U-EDGING TILE* 15x60x15	CORDOLO L* L-KERB TILE* 15x60x20	CANALINA* GUTTER TILE* 15x60x8	GRIGLIA GRID TILE 15x60
LAVORAZIONE ROMPIGOCCIA NON-DRIP EDGE	SU 2 LATI LUNGH ON THE 2 LONG SIDES	SU 3 LATI ON 3 SIDES	SU 2 LATI LUNGH ON THE 2 LONG SIDES	SU 3 LATI ON 3 SIDES						
Woodsense XT20 Beige	R87J	R84P	R89S	R89N	R81W	R88E	R87S	R87W	R87N	R88S
Woodsense XT20 Marrone	R87K	R84Q	R89T	R89P	R82D	R88F	R87T	R87X	R87P	R88A
Woodsense XT20 Grigio	R87L	R84R	R89U	R89Q	R82E	R88G	R87U	R87Y	R87Q	R88C

Tutti i pezzi speciali sono su richiesta e sono coordinabili ai fondi rettificati. Gli imballi vengono calcolati sulla base del quantitativo ordinato. Alle Formteile sind auf Anfrage erhältlich und mit den rektifizierten Grundfliesen kombinierbar. Die Verpackung wird auf der Grundlage der Bestellmenge berechnet. Todas las piezas especiales se entregan bajo pedido y se pueden coordinar con los fondos rettificados. Los embalajes se calculan según las cantidades encargadas en los pedidos.

All special pieces are supplied to order and can be matched with the rectified plain tiles. Packaging is calculated on the basis of the quantity ordered. Toutes les pièces spéciales sont fabriquées sur demande et coordonnables aux fonds rectifiés. Les emballages sont calculés en fonction de la quantité commandée. Все специальные изделия производятся на заказ и сочетаются с обрезной фоновой плиткой. Упаковки рассчитываются на основе заказанного количества.

Per le pavimentazioni esterne non protette, Ragno consiglia di creare una pendenza ≥ 1,5% sulla superficie calpestabile allo scopo di limitare il formarsi di ristagni d'acqua localizzati. Nel caso in cui questi ristagni permangano sulla superficie delle piastrelle nonostante una posa a regola d'arte, è necessario intervenire meccanicamente con l'utilizzo di scope o aspira-liquidi. / For unprotected outdoor pavings, Ragno recommends the creation of a gradient of ≥ 1.5% on the finished surface, to prevent the formation of patches of standing water. In the event that standing water persists on the surface of the tiles in spite of correct installation, it must be removed mechanically with the aid of brooms or wet-and-dry vacuum cleaners. / Zur Unterbindung von punktueller Stauwasserbildung bei Belägen in ungeschützten Außenbereichen, empfiehlt die Ragno die Ausbildung eines Gefälles ≥ 1,5% auf der Trittläche. Sollte trotz fachgerechter Verlegung Stauwasser auf der Fliesenoberfläche zurückbleiben, ist dessen mechanische Entfernung mit Hilfe eines Besens oder Nasssaugers erforderlich. / Pour des sols extérieurs non protégés, Ragno conseille de créer une inclinaison ≥ 1,5 % sur la surface de piétinement en vue de limiter la stagnation localisée de l'eau. Si, malgré une pose dans les règles de l'art, cette stagnation devait persister à la surface des carreaux, une intervention mécanique, au moyen de balais et d'aspirateurs de liquides, est alors nécessaire. / En el caso de pavimentaciones exteriores no protegidas, Ragno recomienda crear una pendiente ≥ 1,5% en la superficie transitable para limitar la formación de depósitos localizados de agua estancada. En caso de que estos depósitos de agua permanezcan en la superficie del azulejo, aun cuando la colocación se haya realizado correctamente, será necesario intervenir mecánicamente empleando un cepillo o un aspirador de líquidos. / Для наружных незащищенных полов Ragno рекомендует создавать уклон ≥ 1,5% на пешеходной поверхности для снижения образования локальных застоев воды. В случае, если застои воды образуются на плитке несмотря на правильную укладку, необходимо прибегать к использованию механических средств, таких как щетки или же аппараты для сбора жидкостей.

# Woodspace XT20

40x120



R6H5 Woodspace XT20 Beige rettificato 40x120

XT20

# Woodspace XT20

40x120

Gruppo Bla UNI EN 14411\_G

gres fine porcellanato colorato in massa - rettificato monocalibro / colorbody fine porcelain stoneware - rectified monocaliber / durchgefärbtes feinsteinzeug - rektifiziert, in einem werkmaß / grès cérame fin coloré dans la masse - rectifié monocalibre / gres porcelánico fino coloreado en toda la masa - rectificado monocalibre / гомогенный мелкозернистый керамогранит - ректифицированный монокалиберный



superfici / surfaces / finitions / oberflächen / superficies / поверхности: outdoor



R6H5 Woodspace XT20 Beige rettificato 40x120



R6H9 Woodspace XT20 Tortora rettificato 40x120



R6H7 Woodspace XT20 Marrone rettificato 40x120



## tech info

\*

Assemblato (pag. 592) / Two-piece L-tile (page 592) / Randstein zweitellig (S. 592) / Assemblé (page 592) / Montado (pág. 592) / Собранная (стр. 592)



Significativa variazione di aspetto superficiale, grafica e colore da piastrella a piastrella e all'interno della stessa piastrella. Si consiglia di visionare la gamma cromatica prima della selezione del materiale. / Significant variation in texture, pattern and colour from tile to tile within the same production run. The colour range should be viewed before selecting the material. / Bedeutende Variation in Aussehen, Struktur und Farbe von Fliese zu Fliese und in ein und derselben Fliese. Es wird empfohlen, das Farbsortiment vor der Auswahl des Materials zu prüfen. / Variation significative au niveau de l'aspect, de la fantaisie et de la couleur entre les carreaux et au sein d'un même carreau. Il est recommandé de consulter la gamme des couleurs avant de sélectionner le matériel. / Variación considerable en el aspecto superficial, los motivos y el color entre un azulejo y otro y dentro del propio azulejo. Es aconsejable visualizar la gama cromática antes de seleccionar el material. / Значительные отличия вида поверхности, графики и цвета у разных плиток и на одной и той же плитке. Перед отбором материала рекомендуется просмотреть цветовую гамму.

## imballi / packaging / verpackungen / emballages / embalajes / упаковки

Scatole / Box / Karton / Boîte / Caja / Коробки Pallet / Pallet / Palette / Palette / Pallet / Поддон



## fondi / plain tiles / grundfliesen / fonds / fondos / фоновая плитка

40x120	rettificato	1	0,48	22,10	48	23,04	1060,50	20
--------	-------------	---	------	-------	----	-------	---------	----

## pezzi speciali / trims / spezialteile / pièces spéciales / piezas especiales / специальные изделия

	GRADONE* STEP TILE* 40x120	GRADONE* STEP TILE* 40x120	GRADONE* STEP TILE* 40x120	GRADONE* STEP TILE* 40x120	ALZATA RISER TILE 20x120	ALZATA RISER TILE 20x120	ALZATA RISER TILE 20x120
LAVORAZIONE LATI TAGLIO + ASSEMBLAGGIO EDGES PRODUCED BY CUTTING + ASSEMBLY	SOLO SU LATO LUNGO ON LONG SIDE ONLY	LATO LUNGO + SX LONG SIDE + L	LATO LUNGO + DX LONG SIDE + R	LATO LUNGO + DX + SX LONG SIDE + R + L	NESSUN LATO LAVORATO NO SHAPED EDGES	ENTRAMBI I LATI CORTI BOTH SHORT SIDES	DX/SX RIBALTABILE RL REVERSIBLE
Woodspace XT20 Beige	R6JM	R6JU	R6K1	R6KA	R6KJ	R6KS	R6KZ
Woodspace XT20 Marrone	R6JP	R6JW	R6K3	R6KD	R6KL	R6KU	R6LA
Woodspace XT20 Tortora	R6JR	R6JY	R6K5	R6KF	R6KP	R6KW	R6LD
	COPRI MURETTO COPING TILE 40x120	COPRI MURETTO COPING TILE 40x120	ELEMENTO ELLE* L-EDGING TILE* 15x120x4	BORDO U* U-EDGING TILE* 15x60x15	CORDOLO L* L-KERB TILE* 15x60x20	CANALINA* GUTTER TILE* 15x60x8	GRIGLIA GRID TILE 15x60
LAVORAZIONE ROMPIGOCCIA NON-DRIP EDGE	SU 2 LATI LUNGI ON THE 2 LONG SIDES	SU 3 LATI ON 3 SIDES					
Woodspace XT20 Beige	R6LR	R6LG	R6JE	R6MG	R6PC	R6LY	R6PQ
Woodspace XT20 Marrone	R6LT	R6LJ	R6JG	R6MJ	R6PE	R6MA	R6PS
Woodspace XT20 Tortora	R6LV	R6LN	R6JJ	R6NZ	R6PG	R6MD	R6PU

Tutti i pezzi speciali sono su richiesta e sono coordinabili ai fondi rettificati. Gli imballi vengono calcolati sulla base del quantitativo ordinato.

All special pieces are supplied to order and can be matched with the rectified plain tiles. Packaging is calculated on the basis of the quantity ordered.

Alle Formteile sind auf Anfrage erhältlich und mit den rektifizierten Grundfliesen kombinierbar. Die Verpackung wird auf der Grundlage der Bestellmenge berechnet.

Toutes les pièces spéciales sont fabriquées sur demande et coordonnables aux fonds rectifiés. Les emballages sont calculés en fonction de la quantité commandée.

Todas las piezas especiales se entregan bajo pedido y se pueden coordinar con los fondos rectificados. Los embalajes se calculan según las cantidades encargadas en los pedidos.

Все специальные изделия производятся на заказ и сочетаются с обрезной фоновой плиткой. Упаковки рассчитываются на основе заказанного количества.

Per le pavimentazioni esterne non protette, Ragno consiglia di creare una pendenza  $\geq 1,5\%$  sulla superficie calpestabile allo scopo di limitare il formarsi di ristagni d'acqua localizzati. Nel caso in cui questi ristagni permangano sulla superficie delle piastrelle nonostante una posa a regola d'arte, è necessario intervenire meccanicamente con l'utilizzo di scope o aspira-liquidi. / For unprotected outdoor pavings, Ragno recommends the creation of a gradient of  $\geq 1.5\%$  on the finished surface, to prevent the formation of patches of standing water. In the event that standing water persists on the surface of the tiles in spite of correct installation, it must be removed mechanically with the aid of brooms or wet-and-dry vacuum cleaners. / Zur Unterbindung von punktueller Stauwasserbildung bei Belägen in ungeschützten Außenbereichen, empfiehlt die Ragno die Ausbildung eines Gefälles  $\geq 1,5\%$  auf der Trittläche. Sollte trotz fachgerechter Verlegung Stauwasser auf der Fliesenoberfläche zurückbleiben, ist dessen mechanische Entfernung mit Hilfe eines Besens oder Nasssaugers erforderlich. / Pour des sols extérieurs non protégés, Ragno conseille de créer une inclinaison  $\geq 1,5\%$  sur la surface de piétinement en vue de limiter la stagnation localisée de l'eau. Si, malgré une pose dans les règles de l'art, cette stagnation devait persister à la surface des carreaux, une intervention mécanique, au moyen de balais et d'aspirateurs de liquides, est alors nécessaire. / En el caso de pavimentaciones exteriores no protegidas, Ragno recomienda crear una pendiente  $\geq 1,5\%$  en la superficie transitable para limitar la formación de depósitos localizados de agua estancada. En caso de que estos depósitos de agua permanezcan en la superficie del azulejo, aun cuando la colocación se haya realizado correctamente, será necesario intervenir mecánicamente empleando un cepillo o un aspirador de líquidos. / Для наружных незащищенных полов Ragno рекомендует создавать уклон  $\geq 1,5\%$  на пешеходной поверхности для снижения образования локальных застоев воды. В случае, если застои воды образуются на плитке несмотря на правильную укладку, необходимо прибегать к использованию механических средств, таких как щетки или же аппараты для сбора жидкостей.



# Woodliving XT20

40x120



R4RE Woodliving XT20 Rovere Biondo rettificato

# Woodliving XT20

40x120

Gruppo Bia UNI EN 14411\_G

gres fine porcellanato colorato in massa - rettificato monocalibro / colorbody fine porcelain stoneware - rectified monocaliber / durchgefärbtes feinsteinzeug - rektifiziert, in einem werkmaß / grès cérame fin coloré dans la masse - rectifié monocalibre / gres porcelánico fino coloreado en toda la masa - retificado monocalibre / гомогенный мелкозернистый керамогранит - ректифицированный монокалиберный



superfici / surfaces / finitions / oberflächen / superficies / поверхности:  
outdoor



**R4RE** Woodliving XT20 Rovere Biondo rettificato 40x120 **H**



**R4RF** Woodliving XT20 Rovere Scuro rettificato 40x120 **H**



**R4RH** Woodliving XT20 Rovere Fumo rettificato 40x120 **G**

## tech info

\*

Assemblato (pag. 592) / Two-piece L-tile (page 592) / Randstein zweiteilig (S. 592) / Assemblé (page 592) / Montado (pág. 592) / Собранная (стр. 592)



Apprezzabili differenze nell'aspetto di superficie e grafica all'interno della stessa produzione. / Clearly distinguishable differences in texture and pattern within the same production run. / Auffällige Unterschiede in Aussehen und Struktur innerhalb der gleichen Produktionscharge. / Différences visibles au niveau de l'aspect et de la fantaisie entre les carreaux du même lot de production. / Diferencias visibles en el aspecto de la superficie y los motivos dentro de un mismo lote de producción. / Заметные отличия вида поверхности и графики в одной и той же партии.



Vedi Appendice pag. 585  
See Appendix page 585  
Siehe Anhang S. 585  
Voir Annexe page 585  
Véase la pág. 585 del Apéndice  
Смотри приложение на стр. 585

imballi / packaging / verpackungen / emballages / embalajes / упаковки

Scatole / Box / Karton / Boite / Caja / Коробки Pallet / Pallet / Palette / Palette / Pallet / Поддон



fondi / plain tiles / grundfliesen / fonds / fondos / фоновая плитка

40x120	1	0,48	22,10	48	23,04	1060,50	20
<b>pezzi speciali / trims / spezialteile / pièces spéciales / piezas especiales / специальные изделия</b>							
40x120x4 E. ELLE	1	0,48	26,93				
40x120 SC.	1	0,48	22,64				

pezzi speciali / trims / spezialteile / pièces spéciales / piezas especiales / специальные изделия

	GRADONE* STEP TILE* 40x120	GRADONE* STEP TILE* 40x120	GRADONE* STEP TILE* 40x120	GRADONE* STEP TILE* 40x120	ALZATA RISER TILE 20x120	ALZATA RISER TILE 20x120	ALZATA RISER TILE 20x120
LAVORAZIONE LATI TAGLIO + ASSEMBLAGGIO EDGES PRODUCED BY CUTTING + ASSEMBLY	SOLO SU LATO LUNGO ON LONG SIDE ONLY	LATO LUNGO + SX LONG SIDE + L	LATO LUNGO + DX LONG SIDE + R	LATO LUNGO + DX + SX LONG SIDE + R + L	NESSUN LATO LAVORATO NO SHAPED EDGES	ENTRAMBI I LATI CORTI BOTH SHORT SIDES	DX/SX RIBALTABILE RL REVERSIBLE
Woodliving XT20 Rovere Biondo	R4UA	R56R	R56U	R56X	R5CT	R5CW	R5CZ
Woodliving XT20 Rovere Scuro	R4UC	R56S	R56V	R56Y	R5CU	R5CX	R5DA
Woodliving XT20 Rovere Fumo	R4UD	R56T	R56W	R56Z	R5CV	R5CY	R5DC
	COPRI MURETTO COPING TILE 40x120	COPRI MURETTO COPING TILE 40x120	ELEMENTO ELLE* L-EDGING TILE* 40x120x4	BORDO U* U-EDGING TILE* 15x60x15	CORDOLO L* L-KERB TILE* 15x20x60	CANALINA* GUTTER TILE* 15x60x8	GRIGLIA GRID TILE 15x60
LAVORAZIONE ROMPIGOCCIA NON-DRIP EDGE	SU 2 LATI LUNGHI ON THE 2 LONG SIDES	SU 3 LATI ON 3 SIDES					
Woodliving XT20 Rovere Biondo	R5DR	R5DU	R4TX	R5DG	R5DK	R5DD	R5DN
Woodliving XT20 Rovere Scuro	R5DS	R5DV	R4TY	R5DH	R5DL	R5DE	R5DP
Woodliving XT20 Rovere Fumo	R5DT	R5DW	R4TZ	R5DJ	R5DM	R5DF	R5DQ

Tutti i pezzi speciali sono su richiesta e sono coordinabili ai fondi rettificati. Gli imballi vengono calcolati sulla base del quantitativo ordinato.

All special pieces are supplied to order and can be matched with the rectified plain tiles. Packaging is calculated on the basis of the quantity ordered.

Alle Formteile sind auf Anfrage erhältlich und mit den rektifizierten Grundfliesen kombinierbar. Die Verpackung wird auf der Grundlage der Bestellmenge berechnet.

Toutes les pièces spéciales sont fabriquées sur demande et coordonnables aux fonds rectifiés. Les emballages sont calculés en fonction de la quantité commandée.

Todas las piezas especiales se entregan bajo pedido y se pueden coordinar con los fondos rectificados. Los embalajes se calculan según las cantidades encargadas en los pedidos.

Все специальные изделия производятся на заказ и сочетаются с обрезной фоновой плиткой. Упаковки рассчитываются на основе заказанного количества.

Per le pavimentazioni esterne non protette, Ragno consiglia di creare una pendenza  $\geq 1,5\%$  sulla superficie calpestabile allo scopo di limitare il formarsi di ristagni d'acqua localizzati. Nel caso in cui questi ristagni permangano sulla superficie delle piastrelle nonostante una posa a regola d'arte, è necessario intervenire meccanicamente con l'utilizzo di scope o aspira-liquidi. / For unprotected outdoor pavings, Ragno recommends the creation of a gradient of  $\geq 1.5\%$  on the finished surface, to prevent the formation of patches of standing water. In the event that standing water persists on the surface of the tiles in spite of correct installation, it must be removed mechanically with the aid of brooms or wet-and-dry vacuum cleaners. / Zur Unterbindung von punktueller Stauwasserbildung bei Belägen in ungeschützten Außenbereichen, empfiehlt die Ragno die Ausbildung eines Gefälles  $\geq 1,5\%$  auf der Trittlfläche. Sollte trotz fachgerechter Verlegung Stauwasser auf der Fliesenoberfläche zurückbleiben, ist dessen mechanische Entfernung mit Hilfe eines Besens oder Nasssaugers erforderlich. / Pour des sols extérieurs non protégés, Ragno conseille de créer une inclinaison  $\geq 1,5\%$  sur la surface de piétinement en vue de limiter la stagnation localisée de l'eau. Si, malgré une pose dans les règles de l'art, cette stagnation devait persister à la surface des carreaux, une intervention mécanique, au moyen de balais et d'aspirateurs de liquides, est alors nécessaire. / En el caso de pavimentaciones exteriores no protegidas, Ragno recomienda crear una pendiente  $\geq 1,5\%$  en la superficie transitable para limitar la formación de depósitos localizados de agua estancada. En caso de que estos depósitos de agua permanezcan en la superficie del azulejo, aun cuando la colocación se haya realizado correctamente, será necesario intervenir mecánicamente empleando un cepillo o un aspirador de líquidos. / Для наружных незащищенных полов Ragno рекомендует создавать уклон  $\geq 1,5\%$  на пешеходной поверхности для снижения образования локальных застоев воды. В случае, если застои воды образуются на плитке несмотря на правильную укладку, необходимо прибегать к использованию механических средств, таких как щетки или же аппараты для сбора жидкостей.

# Woodtale XT20

40x120 60x60



R51V Woodtale XT20 Betulla rettificato 40x120

# Woodtale XT20

40x120 60x60

gres fine porcellanato colorato in massa - rettificato monocalibro / colorbody fine porcelain stoneware - rectified monocaliber / durchgefärbtes feinsteinzeug - rektifiziert, in einem werkmaß / grès cérame fin coloré dans la masse - rectifié monocalibre / gres porcelánico fino coloreado en toda la masa - rectificado monocalibre / гомогенный мелкозернистый керамогранит - ректифицированный монокалиберный



superfici / surfaces / finitions / oberflächen / superficies / поверхности: outdoor



H

R51V Woodtale XT20 Betulla rettificato  
40x120



H

R51W Woodtale XT20 Miele rettificato  
40x120



H

R51X Woodtale XT20 Nocciola rettificato  
40x120



H

R51Y Woodtale XT20 Noce rettificato  
40x120

XT20

# Woodtale XT20

40x120 60x60

gres fine porcellanato colorato in massa - rettificato monocalibro / colorbody fine porcelain stoneware - rectified monocaliber / durchgefärbtes feinsteinzeug - rektifiziert, in einem werkmaß / grès cérame fin coloré dans la masse - rectifié monocalibre / gres porcelánico fino coloreado en toda la masa - rectificado monocalibre / гомогенный мелкозернистый керамогранит - ректифицированный монокалиберный

superfici / surfaces / finitions / oberflächen / superficies / поверхности  
outdoor



R4XF Woodtale XT20 Betulla rettificato  
60x60



R4XG Woodtale XT20 Miele rettificato  
60x60



R4XH Woodtale XT20 Nocciola rettificato  
60x60



R4XJ Woodtale XT20 Noce rettificato  
60x60



## tech info

\*

Assemblato (pag. 592) / Two-piece L-tile (page 592) / Randstein zweiteilig (S. 592) / Assemblé (page 592) / Montado (pág. 592) / Собранный (стр. 592)



Significativa variazione di aspetto superficiale, grafica e colore da piastrella a piastrella e all'interno della stessa piastrella. Si consiglia di visionare la gamma cromatica prima della selezione del materiale. / Significant variation in texture, pattern and colour from tile to tile within the same production run. The colour range should be viewed before selecting the material. / Bedeutende Variation in Aussehen, Struktur und Farbe von Fliese zu Fliese und in ein und derselben Fliese. Es wird empfohlen, das Farbsortiment vor der Auswahl des Materials zu prüfen. / Variation significative au niveau de l'aspect, de la fantaisie et de la couleur entre les carreaux et au sein d'un même carreau. Il est recommandé de consulter la gamme des couleurs avant de sélectionner le matériel. / Variación considerable en el aspecto superficial, los motivos y el color entre un azulejo y otro y dentro del propio azulejo. Es aconsejable visualizar la gama cromática antes de seleccionar el material. / Значительные отличия вида поверхности, графики и цвета у разных плиток и на одной и той же плитке. Перед отбором материала рекомендуется посмотреть цветовую гамму.



Vedi Appendice pag. 585  
See Appendix page 585  
Siehe Anhang S. 585  
Voir Annexe page 585  
Véase la pág. 585 del Apéndice  
Смотри приложение на стр. 585

## imballi / packaging / verpackungen / emballages / embalajes / упаковки

Scatole / Box / Karton / Boite / Caja / Коробки	Pallet / Pallet / Palette / Palette / Pallet / Поддон	≠ mm
M <sup>2</sup> KG	M <sup>2</sup> KG	

fondi / plain tiles / grundfliesen / fonds / fondos / фоновая плитка	40x120	1	0,48	22,10	48	23,04	1060,50	20
60x60	2	0,72	34,26	32	23,04	1096,15	20	

**pezzi speciali / trims / spezialteile / pièces spéciales / piezas especiales / специальные изделия**

15x60x4	E. ELLE	2	0,18	5,61				
---------	---------	---	------	------	--	--	--	--

## pezzi speciali / trims / spezialteile / pièces spéciales / piezas especiales / специальные изделия

	GRADONE* STEP TILE* 30x60	GRADONE* STEP TILE* 30x60	GRADONE* STEP TILE* 30x60	GRADONE* STEP TILE* 30x60	GRADONE* STEP TILE* 40x120	GRADONE* STEP TILE* 40x120	GRADONE* STEP TILE* 40x120	GRADONE* STEP TILE* 40x120
LAVORAZIONE LATI TAGLIO + ASSEMBLAGGIO EDGES PRODUCED BY CUTTING + ASSEMBLY	SOLO SU LATO LUNGO ON LONG SIDE ONLY	LATO LUNGO + SX LONG SIDE + L	LATO LUNGO + DX LONG SIDE + R	LATO LUNGO + DX + SX LONG SIDE + R + L	SOLO SU LATO LUNGO ON LONG SIDE ONLY	LATO LUNGO + SX LONG SIDE + L	LATO LUNGO + DX LONG SIDE + R	LATO LUNGO + DX + SX LONG SIDE + R + L
Woodtale XT20 Betulla	R5EC	R5EG	R5EL	R5EQ	R5GJ	R5GN	R5GS	R5GW
Woodtale XT20 Miele	R5ED	R5EH	R5EM	R5ER	R5GK	R5GP	R5GT	R5GX
Woodtale XT20 Nocciola	R5EE	R5EJ	R5EN	R5ES	R5GL	R5GQ	R5GU	R5GY
Woodtale XT20 Noce	R5EF	R5EK	R5EP	R5ET	R5GM	R5GR	R5GV	R5GZ

	ALZATA RISER TILE 20x60	ALZATA RISER TILE 20x60	ALZATA RISER TILE 20x60	ALZATA RISER TILE 20x120	ALZATA RISER TILE 20x120	ALZATA RISER TILE 20x120
LAVORAZIONE LATI EDGE SHAPING	NESSUN LATO LAVORATO NO SHAPED EDGES	ENTRAMBI I LATI CORTI BOTH SHORT SIDES	DX/SX RIBALTABILE RL REVERSIBLE	NESSUN LATO LAVORATO NO SHAPED EDGES	ENTRAMBI I LATI CORTI BOTH SHORT SIDES	DX/SX RIBALTABILE RL REVERSIBLE
Woodtale XT20 Betulla	R5EU	R5EY	R5FD	R5HA	R5HF	R5HK
Woodtale XT20 Miele	R5EV	R5EZ	R5FE	R5HC	R5HG	R5HL
Woodtale XT20 Nocciola	R5EW	R5FA	R5FF	R5HD	R5HH	R5YL
Woodtale XT20 Noce	R5EX	R5FC	R5FG	R5HE	R5HJ	R5X7

	COPRI MURETTO COPING TILE 30x60	COPRI MURETTO COPING TILE 30x60	COPRI MURETTO COPING TILE 40x120	COPRI MURETTO COPING TILE 40x120	ELEMENTO ELLE* L-EDGING TILE* 15x60x4	ELEMENTO ELLE* L-EDGING TILE* 15x120x4	BORDO U* U-EDGING TILE* 15x60x15	CORDOLO U* L-KERB TILE* 15x20x60	CANALINA* GUTTER TILE* 15x60x8	GRIGLIA GRID TILE 15x60
LAVORAZIONE ROMPIGOCCIA NON-DRIP EDGE	SU 2 LATI LUNGHI ON THE 2 LONG SIDES	SU 3 LATI ON 3 SIDES	SU 2 LATI LUNGHI ON THE 2 LONG SIDES	SU 3 LATI ON 3 SIDES						
Woodtale XT20 Betulla	R5FZ	R5GE	R63D	R6KM	R4XK	R70D	R5FM	R5FR	R5FH	R5FV
Woodtale XT20 Miele	R5GA	R5GF	R58N	R57P	R4XL	R5YC	R5FN	R5FS	R5FJ	R5FW
Woodtale XT20 Nocciola	R5GC	R5GG	R6JN	R68F	R4XM	R5UM	R5FP	R5FT	R5FK	R5FX
Woodtale XT20 Noce	R5GD	R5GH	R61A	R5VV	R4XN	R6VR	R5FQ	R5FU	R5FL	R5FY

Tutti i pezzi speciali sono su richiesta e sono coordinabili ai fondi rettificati. Gli imballi vengono calcolati sulla base del quantitativo ordinato.

All special pieces are supplied to order and can be matched with the rectified plain tiles. Packaging is calculated on the basis of the quantity ordered.

Alle Formteile sind auf Anfrage erhältlich und mit den rektifizierten Grundfliesen kombinierbar. Die Verpackung wird auf der Grundlage der Bestellmenge berechnet.

Toutes les pièces spéciales sont fabriquées sur demande et coordonnables aux fonds rectifiés. Les emballages sont calculés en fonction de la quantité commandée.

Todas las piezas especiales se entregan bajo pedido y se pueden coordinar con los fondos rectificados. Los embalajes se calculan según las cantidades encargadas en los pedidos.

Все специальные изделия производятся на заказ и сочетаются с обрезной фоновой плиткой. Упаковки рассчитываются на основе заказанного количества.

Per le pavimentazioni esterne non protette, Ragno consiglia di creare una pendenza ≥ 1,5% sulla superficie calpestabile allo scopo di limitare il formarsi di ristagni d'acqua localizzati. Nel caso in cui questi ristagni permangano sulla superficie delle piastrelle nonostante una posa a regola d'arte, è necessario intervenire meccanicamente con l'utilizzo di scope o aspiratori-liquidi. / For unprotected outdoor pavings, Ragno recommends the creation of a gradient of ≥ 1.5% on the finished surface, to prevent the formation of patches of standing water. In the event that standing water persists on the surface of the tiles in spite of correct installation, it must be removed mechanically with the aid of brooms or wet-and-dry vacuum cleaners. / Zur Unterbindung von punktueller Stauwasserbildung bei Belägen in ungeschützten Außenbereichen, empfiehlt die Ragno die Ausbildung eines Gefälles ≥ 1,5% auf der Trittläche. Sollte trotz fachgerechter Verlegung Stauwasser auf der Fliesenoberfläche zurückbleiben, ist dessen mechanische Entfernung mit Hilfe eines Besens oder Nasssaugers erforderlich. / Pour des sols extérieurs non protégés, Ragno conseille de créer une inclinaison ≥ 1,5 % sur la surface de piétinement en vue de limiter la stagnation localisée de l'eau. Si, malgré une pose dans les règles de l'art, cette stagnation devait persister à la surface des carreaux, une intervention mécanique, au moyen de balais et d'aspirateurs de liquides, est alors nécessaire. / En el caso de pavimentaciones exteriores no protegidas, Ragno recomienda crear una pendiente ≥ 1,5% en la superficie transitabile para limitar la formación de depósitos localizados de agua estancada. En caso de que estos depósitos de agua permanezcan en la superficie del azulejo, aun cuando la colocación se haya realizado correctamente, será necesario intervenir mecánicamente empleando un cepillo o un aspirador de líquidos. / Для наружных незащищенных полов Ragno рекомендует создавать уклон ≥ 1,5% на пешеходной поверхности для снижения образования локальных застоев воды. В случае, если застои воды образуются на плитке несмотря на правильную укладку, необходимо прибегать к использованию механических средств, таких как щетки или же аппараты для сбора жидкостей.

# Woodmania XT20

40x120



RSTT Woodmania XT20 Musk rettificato 40x120

XT20

# Woodmania XT20

40x120

Gruppo Bla UNI EN 14411\_G

gres fine porcellanato colorato in massa - rettificato monocalibro / colorbody fine porcelain stoneware - rectified monocaliber / durchgefärbtes feinsteinzeug - rektifiziert, in einem werkmaß / grès cérame fin coloré dans la masse - rectifié monocalibre / gres porcelánico fino coloreado en toda la masa - rectificado monocalibre / гомогенный мелкозернистый керамогранит - ректифицированный монокалиберный



superfici / surfaces / finitions / oberflächen / superficies / поверхности: outdoor



H

R5TR Woodmania XT20 Honey rettificato 40x120



G

R5TS Woodmania XT20 Caramel rettificato 40x120



G

R5TT Woodmania XT20 Musk rettificato 40x120

## tech info

\*

Assemblato (pag. 592) / Two-piece L-tile (page 592) / Randstein zweiteilig (S. 592) / Assemblé (page 592) / Montado (pág. 592) / Собранная (стр. 592)



Variazioni irregolari da piastrella a piastrella. Una piastrella può differire totalmente nell'aspetto superficiale e colore da un'altra. Si consiglia di visionare la gamma cromatica prima della selezione del materiale. / Random differences from tile to tile. One tile may have totally different texture and colour from another. The colour range should be viewed before selecting the material. / Wesentliche Variationen von Fliese zu Fliese. Eine Fliese kann sich in Aussehen und Farbe komplett von einer anderen unterscheiden. Es wird empfohlen, das Farbsortiment vor der Auswahl des Materials zu prüfen. / Variations irrégulières entre les carreaux. L'aspect et la couleur peuvent être complètement différents d'un carreau à l'autre. Il est recommandé de consulter la gamme des couleurs avant de sélectionner le matériel. / Variaciones irregulares entre un azulejo y otro. Un azulejo puede ser completamente diferente de otro en el aspecto superficial y el color. Es aconsejable visualizar la gama cromática antes de seleccionar el material. / Неоднородные изменения на разных плитках. Каждая плитка может полностью отличаться по виду поверхности и цвету от другой. Перед отбором материала рекомендуется посмотреть цветовую гамму.



Vedi Appendice pag. 585  
See Appendix page 585  
Siehe Anhang S. 585  
Voir Annexe page 585  
Véase la pág. 585 del Apéndice  
Смотри приложение на стр. 585

imballi / packaging / verpackungen / emballages / embalajes / упаковки

Scatole / Box / Karton / Boite / Caja / Коробки

Pallet / Pallet / Palette / Palette / Pallet / Поддон



fondi / plain tiles / grundfliesen / fonds / fondos / фоновая плитка						
40x120 Rett.	1	0,48	22,99	48	23,04	1103,26

## pezzi speciali / trims / spezialteile / pièces spéciales / piezas especiales / специальные изделия

	GRADONE* STEP TILE* 40x120	GRADONE* STEP TILE* 40x120	GRADONE* STEP TILE* 40x120	GRADONE* STEP TILE* 40x120	ALZATA RISER TILE 20x120	ALZATA RISER TILE 20x120	ALZATA RISER TILE 20x120
LAVORAZIONE LATI TAGLIO + ASSEMBLAGGIO EDGES PRODUCED BY CUTTING + ASSEMBLY	SOLO SU LATO LUNGO ON LONG SIDE ONLY	LATO LUNGO + SX LONG SIDE + L	LATO LUNGO + DX LONG SIDE + R	LATO LUNGO + DX + SX LONG SIDE + R + L	NESSUN LATO LAVORATO NO SHAPED EDGES	ENTRAMBI I LATI CORTI BOTH SHORT SIDES	DX/SX RIBALTABILE RL REVERSIBLE
Woodmania XT20 Honey	RAVC	RAVF	RAVJ	RAVM	RAVT	RAVW	RAWO
Woodmania XT20 Caramel	RAVD	RAVG	RAVK	RAVN	RAVU	RAVX	RAW1
Woodmania XT20 Musk	RAVE	RAVH	RAVL	RAVP	RAVV	RAVY	RAW2
	COPRI MURETTO COPING TILE 40x120	COPRI MURETTO COPING TILE 40x120	ELEMENTO ELLE* L-EDGING TILE* 15x120x4	BORDO U* U-EDGING TILE* 15x60x15	CORDOLO L* L-KERB TILE* 15x60x20	CANALINA* GUTTER TILE* 15x60x8	GRIGLIA GRID TILE 15x60
LAVORAZIONE ROMPIGOCCIA NON-D RIP EDGE	SU 2 LATI LUNGI ON THE 2 LONG SIDES	SU 3 LATI ON 3 SIDES					
Woodmania XT20 Honey	RAW6	RAW3	RAV8	RAWD	RAWG	RAW9	RAWK
Woodmania XT20 Caramel	RAW7	RAW4	RAV9	RAWE	RAWH	RAWA	RAWL
Woodmania XT20 Musk	RAW8	RAW5	RAVA	RAWF	RAWJ	RAWC	RAWM

Tutti i pezzi speciali sono su richiesta e sono coordinabili ai fondi rettificati. Gli imballi vengono calcolati sulla base del quantitativo ordinato.

All special pieces are supplied to order and can be matched with the rectified plain tiles. Packaging is calculated on the basis of the quantity ordered.

Alle Formteile sind auf Anfrage erhältlich und mit den rektifizierten Grundfliesen kombinierbar. Die Verpackung wird auf der Grundlage der Bestellmenge berechnet.

Toutes les pièces spéciales sont fabriquées sur demande et coordonnables aux fonds rectifiés. Les emballages sont calculés en fonction de la quantité commandée.

Todas las piezas especiales se entregan bajo pedido y se pueden coordinar con los fondos rectificados. Los embalajes se calculan según las cantidades encargadas en los pedidos.

Все специальные изделия производятся на заказ и сочетаются с обрезной фоновой плиткой. Упаковки рассчитываются на основе заказанного количества.

Per le pavimentazioni esterne non protette, Ragno consiglia di creare una pendenza  $\geq 1,5\%$  sulla superficie calpestabile allo scopo di limitare il formarsi di ristagni d'acqua localizzati. Nel caso in cui questi ristagni permangano sulla superficie delle piastrelle nonostante una posa a regola d'arte, è necessario intervenire meccanicamente con l'utilizzo di scope o aspira-liquidi. / For unprotected outdoor pavings, Ragno recommends the creation of a gradient of  $\geq 1.5\%$  on the finished surface, to prevent the formation of patches of standing water. In the event that standing water persists on the surface of the tiles in spite of correct installation, it must be removed mechanically with the aid of brooms or wet-and-dry vacuum cleaners. / Zur Unterbindung von punktueller Stauwasserbildung bei Belägen in ungeschützten Außenbereichen, empfiehlt die Ragno die Ausbildung eines Gefälles  $\geq 1,5\%$  auf der Trittläche. Sollte trotz fachgerechter Verlegung Stauwasser auf der Fliesenoberfläche zurückbleiben, ist dessen mechanische Entfernung mit Hilfe eines Besens oder Nasssaugers erforderlich. / Pour des sols extérieurs non protégés, Ragno conseille de créer une inclinaison  $\geq 1,5\%$  sur la surface de piétinement en vue de limiter la stagnation localisée de l'eau. Si, malgré une pose dans les règles de l'art, cette stagnation devait persister à la surface des carreaux, une intervention mécanique, au moyen de balais et d'aspirateurs de liquides, est alors nécessaire. / En el caso de pavimentaciones exteriores no protegidas, Ragno recomienda crear una pendiente  $\geq 1,5\%$  en la superficie transitabile para limitar la formación de depósitos localizados de agua estancada. En caso de que estos depósitos de agua permanezcan en la superficie del azulejo, aun cuando la colocación se haya realizado correctamente, será necesario intervenir mecánicamente empleando un cepillo o un aspirador de líquidos. / Для наружных незащищенных полов Ragno рекомендует создавать уклон  $\geq 1,5\%$  на пешеходной поверхности для снижения образования локальных застоев воды. В случае, если застои воды образуются на плитке несмотря на правильную укладку, необходимо прибегать к использованию механических средств, таких как щетки или же аппараты для сбора жидкостей.

# Patina XT20

80x80



XT20



# Patina XT20

80x80

Gruppo Bia UNI EN 14411\_G

gres fine porcellanato colorato in massa - rettificato monocoloro / colorbody fine porcelain stoneware - rectified monocolor / durchgefärbtes feinsteinzeug - rektifiziert, in einem werkmaß / grès cérame fin coloré dans la masse - rectifié monocolor / gres porcelánico fino coloreado en toda la masa - rectificado monocolor / гомогенный мелкозернистый керамогранит - ректифицированный монокалиберный



superfici / surfaces / finitions / oberflächen / superficies / поверхности: outdoor



RAWN Patina XT20 Crema rettificato 80x80

H



RAWP Patina XT20 Cognac rettificato 80x80

H



RAWQ Patina XT20 Asfalto rettificato 80x80

H



RAWR Patina XT20 Petrolio rettificato 80x80

H

## tech info

\*

Assemblato (pag. 592) / Two-piece L-tile (page 592) / Randstein zweiteilig (S. 592) / Assemblé (page 592) / Montado (pág. 592) / Собранная (стр. 592)



Vedi Appendice pag. 585  
See Appendix page 585  
Siehe Anhang S. 585  
Voir Annexe page 585  
Véase la pág. 585 del Apéndice  
Смотри приложение на стр. 585



Apprezzabili differenze nell'aspetto di superficie e grafica all'interno della stessa produzione. / Clearly distinguishable differences in texture and pattern within the same production run. / Auffällige Unterschiede in Aussehen und Struktur innerhalb der gleichen Produktionscharge. / Différences visibles au niveau de l'aspect et de la fantaisie entre les carreaux du même lot de production. / Diferencias visibles en el aspecto de la superficie y los motivos dentro de un mismo lote de producción. / Заметные отличия вида поверхности и графики в одной и той же партии.

imballi / packaging / verpackungen / emballages / embalajes / упаковки

Scatole / Box / Karton / Boite / Caja / Коробки	Pallet / Pallet / Palette / Palette / Поддон	mm
M <sup>2</sup>	KG	M <sup>2</sup>
KG	M <sup>2</sup>	KG

fondi / plain tiles / grundfliesen / fonds / fondos / фоновая плитка	80x80	1	0,64	30,50	45	28,80	1373,00	20
--	-------	---	------	-------	----	-------	---------	----

pezzi speciali / trims / spezialteile / pièces spéciales / piezas especiales / специальные изделия

	GRADONE* STEP TILE* 40x80	GRADONE* STEP TILE* 40x80	GRADONE* STEP TILE* 40x80	GRADONE* STEP TILE* 40x80	ALZATA RISER TILE 20x80	ALZATA RISER TILE 20x80	ALZATA RISER TILE 20x80
LAVORAZIONE LATI TAGLIO + ASSEMBLAGGIO EDGES PRODUCED BY CUTTING + ASSEMBLY	SOLO SU LATO LUNGO ON LONG SIDE ONLY	LATO LUNGO + SX LONG SIDE + L	LATO LUNGO + DX LONG SIDE + R	LATO LUNGO + DX + SX LONG SIDE + R + L	NESSUN LATO LAVORATO NO SHAPED EDGES	ENTRAMBI I LATI CORTI BOTH SHORT SIDES	DX/SX RIBALTABILE RL REVERSIBLE
Patina XT20 Crema	RAWZ	RAX3	RAX7	RAXC	RAXG	RAXL	RAXQ
Patina XT20 Cognac	RAX0	RAX4	RAX8	RAXD	RAXH	RAXM	RAXR
Patina XT20 Asfalto	RAX1	RAX5	RAX9	RAXE	RAXJ	RAXN	RAXS
Patina XT20 Petrolio	RAX2	RAX6	RAXA	RAXF	RAXK	RAXP	RAXT
	COPRI MURETTO COPING TILE 40x80	COPRI MURETTO COPING TILE 40x80	ELEMENTO ELLE* L-EDGING TILE* 15x80x4	BORDO U* U-EDGING TILE* 15x80x15	CORDOLO L* L-KERB TILE* 15x80x20	CANALINA* GUTTER TILE* 15x80x8	GRIGLIA GRID TILE 15x80
LAVORAZIONE ROMPIGOCIA NON-DRIP EDGE	SU 2 LATI LUNGH ON THE 2 LONG SIDES	SU 3 LATI ON 3 SIDES					
Patina XT20 Crema	RAXY	RAXU	RAWV	RAY6	RAY2	RAYF	RAYA
Patina XT20 Cognac	RAXZ	RAXV	RAWW	RAY7	RAY3	RAYG	RAYC
Patina XT20 Asfalto	RAY0	RAXW	RAWX	RAY8	RAY4	RAYH	RAYD
Patina XT20 Petrolio	RAY1	RAXX	RAWY	RAY9	RAY5	RAYJ	RAYE

Tutti i pezzi speciali sono su richiesta e sono coordinabili ai fondi rettificati. Gli imballi vengono calcolati sulla base del quantitativo ordinato.

All special pieces are supplied to order and can be matched with the rectified plain tiles. Packaging is calculated on the basis of the quantity ordered.

Alle Formteile sind auf Anfrage erhältlich und mit den rektifizierten Grundfliesen kombinierbar. Die Verpackung wird auf der Grundlage der Bestellmenge berechnet.

Toutes les pièces spéciales sont fabriquées sur demande et coordonnables aux fonds rectifiés. Les emballages sont calculés en fonction de la quantité commandée.

Todas las piezas especiales se entregan bajo pedido y se pueden coordinar con los fondos rectificados. Los embalajes se calculan según las cantidades encargadas en los pedidos.

Все специальные изделия производятся на заказ и сочетаются с обрезной фоновой плиткой. Упаковки рассчитываются на основе заказанного количества.

Per le pavimentazioni esterne non protette, Ragno consiglia di creare una pendenza  $\geq 1,5\%$  sulla superficie calpestabile allo scopo di limitare il formarsi di ristagni d'acqua localizzati. Nel caso in cui questi ristagni permangano sulla superficie delle piastrelle nonostante una posa a regola d'arte, è necessario intervenire meccanicamente con l'utilizzo di scope o aspiratori-liquidi. / For unprotected outdoor pavings, Ragno recommends the creation of a gradient of  $\geq 1,5\%$  on the finished surface, to prevent the formation of patches of standing water. In the event that standing water persists on the surface of the tiles in spite of correct installation, it must be removed mechanically with the aid of brooms or wet-and-dry vacuum cleaners. / Zur Unterbindung von punktueller Stauwasserbildung bei Belägen in ungeschützten Außenbereichen, empfiehlt die Ragno die Ausbildung eines Gefälles  $\geq 1,5\%$  auf der Trittläche. Sollte trotz fachgerechter Verlegung Stauwasser auf der Fliesenoberfläche zurückbleiben, ist dessen mechanische Entfernung mit Hilfe eines Besens oder Nasssaugers erforderlich. / Pour des sols extérieurs non protégés, Ragno conseille de créer une inclinaison  $\geq 1,5\%$  sur la surface de piétinement en vue de limiter la stagnation localisée de l'eau. Si, malgré une pose dans les règles de l'art, cette stagnation devait persister à la surface des carreaux, une intervention mécanique, au moyen de balais et d'aspirateurs de liquides, est alors nécessaire. / En el caso de pavimentaciones exteriores no protegidas, Ragno recomienda crear una pendiente  $\geq 1,5\%$  en la superficie transitable para limitar la formación de depósitos localizados de agua estancada. En caso de que estos depósitos de agua permanezcan en la superficie del azulejo, aun cuando la colocación se haya realizado correctamente, será necesario intervenir mecánicamente empleando un cepillo o un aspirador de líquidos. / Для наружных незащищенных полов Ragno рекомендует создавать уклон  $\geq 1,5\%$  на пешеходной поверхности для снижения образования локальных застоев воды. В случае, если застои воды образуются на плитке несмотря на правильную укладку, необходимо прибегать к использованию механических средств, таких как щетки или же аппараты для сбора жидкостей.

# Rewind XT20

60x60



R4EM Rewind XT20 Corda 60x60

# Rewind XT20

60x60



Gruppo Bla UNI EN 14411\_G

gres fine porcellanato colorato in massa / colorbody fine porcelain stoneware / durchgefärbtes feinsteinzeug in einem werkmaß / grès cérame fin coloré dans la masse / gres porcelánico fino coloreado en toda la masa / гомогенный мелкозернистый керамогранит

gres fine porcellanato colorato in massa - rettificato monocalibro / colorbody fine porcelain stoneware - rectified monocaliber/ durchgefärbtes feinsteinzeug - rektifiziert, in einem werkmaß / grès cérame fin coloré dans la masse - rectifié monocalibre / gres porcelánico fino coloreado en toda la masa - rectificado monocalibre / гомогенный мелкозернистый керамогранит - ректифицированный монокалиберный

superfici / surfaces / finitions / oberflächen / superficies / поверхности: outdoor



R4EJ Rewind XT20 Polvere  
R4HP Rewind XT20 Polvere rettificato  
60x60

H



R4EK Rewind XT20 Peltro  
R4HQ Rewind XT20 Peltro rettificato  
60x60

H



R4EL Rewind XT20 Argilla  
R4HR Rewind XT20 Argilla rettificato  
60x60

H



R4EM Rewind XT20 Corda  
R4HS Rewind XT20 Corda rettificato  
60x60

H

## tech info

\*

Assemblato (pag. 592) / Two-piece L-tile (page 592) / Randstein zweiteilig (S. 592) / Assemblé (page 592) / Montado (pág. 592) / Собранный (стр. 592)



Apprezzabili differenze nell'aspetto di superficie e grafica all'interno della stessa produzione. / Clearly distinguishable differences in texture and pattern within the same production run. / Auffällige Unterschiede in Aussehen und Struktur innerhalb der gleichen Produktionscharge. / Différences visibles au niveau de l'aspect et de la fantaisie entre les carreaux du même lot de production. / Diferencias visibles en el aspecto de la superficie y los motivos dentro de un mismo lote de producción. / Заметные отличия вида поверхности и графики в одной и той же партии.

## imballi / packaging / verpackungen / emballages / embalajes / упаковки

Scatole / Box / Karton / Boite / Caja / Коробки Pallet / Pallet / Palette / Palette / Pallet / Поддон



## fondi / plain tiles / grundfliesen / fonds / fondos / фоновая плитка

60x60	2	0,72	34,79	32	23,04	1113,34	20
60x60	2	0,72	33,73	32	23,04	1079,50	20

## pezzi speciali / trims / spezialteile / pièces spéciales / piezas especiales / специальные изделия

	GRADONE* STEP TILE* 30x60	GRADONE* STEP TILE* 30x60	GRADONE* STEP TILE* 30x60	GRADONE* STEP TILE* 30x60	ALZATA RISER TILE 20x60	ALZATA RISER TILE 20x60	ALZATA RISER TILE 20x60
LAVORAZIONE LATI TAGLIO + ASSEMBLAGGIO EDGES PRODUCED BY CUTTING + ASSEMBLY	SOLO SU LATO LUNGO ON LONG SIDE ONLY	LATO LUNGO + SX LONG SIDE + L	LATO LUNGO + DX LONG SIDE + R	LATO LUNGO + DX + SX LONG SIDE + R + L	NESSUN LATO LAVORATO NO SHAPED EDGES	ENTRambi I LATI CORTI BOTH SHORT SIDES	DX/SX RIBALTABILE RL REVERSIBLE
Rewind XT20 Polvere	R59N	R59S	R59W	R5A9	R5AE	R5AJ	R5AN
Rewind XT20 Peltro	R59P	R59T	R59X	R5AA	R5AF	R5AK	R5AP
Rewind XT20 Argilla	R59Q	R59U	R59Y	R5AC	R5AG	R5AL	R5AQ
Rewind XT20 Corda	R59R	R59V	R59Z	R5AD	R5AH	R5AM	R5AR
	COPRI MURETTO COPING TILE 30x60	COPRI MURETTO COPING TILE 30x60	ELEMENTO ELLE* RETTIFICATO RECTIFIED L-EDGING TILE* 15x60x4	BORDO U* U-EDGING TILE* 15x60x15	CORDOLO L* L-KERB TILE* 15x20x60	CANALINA* GUTTER TILE* 15x60x8	GRIGLIA GRID TILE 15x60
LAVORAZIONE ROMPIGOCCIA NON-DRIP EDGE	SU 2 LATI LUNGH ON THE 2 LONG SIDES	SU 3 LATI ON 3 SIDES					
Rewind XT20 Polvere	R5CK	R5CP	R59J	R5AW	R5CA	R5AS	R5CF
Rewind XT20 Peltro	R5CL	R5CQ	R59K	R5AX	R5CC	R5AT	R5CG
Rewind XT20 Argilla	R5CM	R5CR	R59L	R5AY	R5CD	R5AU	R5CH
Rewind XT20 Corda	R5CN	R5GR	R59M	R5AZ	R5CE	R5AV	R5CJ

Tutti i pezzi speciali sono su richiesta e sono coordinabili ai fondi rettificati. Gli imballi vengono calcolati sulla base del quantitativo ordinato.

All special pieces are supplied to order and can be matched with the rectified plain tiles. Packaging is calculated on the basis of the quantity ordered.

Alle Formteile sind auf Anfrage erhältlich und mit den rektifizierten Grundfliesen kombinierbar. Die Verpackung wird auf der Grundlage der Bestellmenge berechnet.

Toutes les pièces spéciales sont fabriquées sur demande et coordonnables aux fonds rectifiés. Les emballages sont calculés en fonction de la quantité commandée.

Todas las piezas especiales se entregan bajo pedido y se pueden coordinar con los fondos rectificados. Los embalajes se calculan según las cantidades encargadas en los pedidos.

Все специальные изделия производятся на заказ и сочетаются с обрезной фоновой плиткой. Упаковки рассчитываются на основе заказанного количества.

Per le pavimentazioni esterne non protette, Ragno consiglia di creare una pendenza  $\geq 1,5\%$  sulla superficie calpestabile allo scopo di limitare il formarsi di ristagni d'acqua localizzati. Nel caso in cui questi ristagni permangano sulla superficie delle piastrelle nonostante una posa a regola d'arte, è necessario intervenire meccanicamente con l'utilizzo di scope o aspira-liquidi. / For unprotected outdoor pavings, Ragno recommends the creation of a gradient of  $\geq 1.5\%$  on the finished surface, to prevent the formation of patches of standing water. In the event that standing water persists on the surface of the tiles in spite of correct installation, it must be removed mechanically with the aid of brooms or wet-and-dry vacuum cleaners. / Zur Unterbindung von punktueller Stauwasserbildung bei Belägen in ungeschützten Außenbereichen, empfiehlt die Ragno die Ausbildung eines Gefälles  $\geq 1,5\%$  auf der Trittlfläche. Sollte trotz fachgerechter Verlegung Stauwasser auf der Fliesenoberfläche zurückbleiben, ist dessen mechanische Entfernung mit Hilfe eines Besens oder Nasssaugers erforderlich. / Pour des sols extérieurs non protégés, Ragno conseille de créer une inclinaison  $\geq 1,5\%$  sur la surface de piétinement en vue de limiter la stagnation localisée de l'eau. Si, malgré une pose dans les règles de l'art, cette stagnation devait persister à la surface des carreaux, une intervention mécanique, au moyen de balais et d'aspirateurs de liquides, est alors nécessaire. / En el caso de pavimentaciones exteriores no protegidas, Ragno recomienda crear una pendiente  $\geq 1,5\%$  en la superficie transitable para limitar la formación de depósitos localizados de agua estancada. En caso de que estos depósitos de agua permanezcan en la superficie del azulejo, aun cuando la colocación se haya realizado correctamente, será necesario intervenir mecánicamente empleando un cepillo o un aspirador de líquidos. / Для наружных незащищенных полов Ragno рекомендует создавать уклон  $\geq 1,5\%$  на пешеходной поверхности для снижения образования локальных застоев воды. В случае, если застои воды образуются на плитке несмотря на правильную укладку, необходимо прибегать к использованию механических средств, таких как щетки или же аппараты для сбора жидкостей.

# Concept XT20

60x60



R45M Concept XT20 Grigio tuffato 60x60

# Concept XT20

60x60

Gruppo Bla UNI EN 14411\_G

gres fine porcellanato colorato in massa - rettificato monocalibro / colorbody fine porcelain stoneware - rectified monocaliber / durchgefärbtes feinsteinzeug - rektifiziert, in einem werkmaß / grès cérame fin coloré dans la masse - rectifié monocalibre / gres porcelánico fino coloreado en toda la masa - rectificado monocalibre / гомогенный мелкозернистый керамогранит - ректифицированный монокалиберный



superfici / surfaces / finitions / oberflächen / superficies / поверхности: outdoor



R45P Concept XT20 Beige rettificato 60x60



R45N Concept XT20 Greige rettificato 60x60



R45M Concept XT20 Grigio rettificato 60x60

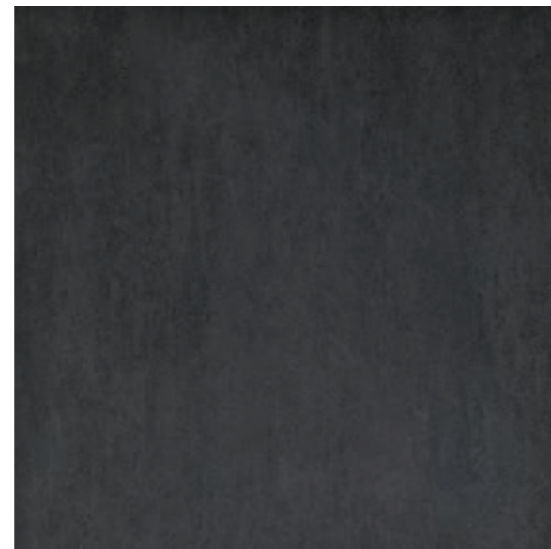

R45Q Concept XT20 Nero rettificato 60x60



## tech info

\*

Assemblato (pag. 592) / Two-piece L-tile (page 592) / Randstein zweiteilig (S. 592) / Assemblé (page 592) / Montado (pág. 592) / Собранный (стр. 592)



Apprezzabili differenze nell'aspetto di superficie e grafica all'interno della stessa produzione. / Clearly distinguishable differences in texture and pattern within the same production run. / Auffällige Unterschiede in Aussehen und Struktur innerhalb der gleichen Produktionscharge. / Différences visibles au niveau de l'aspect et de la fantaisie entre les carreaux du même lot de production. / Diferencias visibles en el aspecto de la superficie y los motivos dentro de un mismo lote de producción. / Заметные отличия вида поверхности и графики в одной и той же партии.

## imballi / packaging / verpackungen / emballages / embalajes / упаковки

Scatole / Box / Karton / Boite / Caja / Коробки	Pallet / Pallet / Palette / Palette / Pallet / Поддон
M <sup>2</sup> KG	M <sup>2</sup> KG  mm

## fondi / plain tiles / grundfliesen / fonds / fondos / фоновая плитка

60x60	2	0,72	32,00	32	23,04	1032,00	20
-------	---	------	-------	----	-------	---------	----

## pezzi speciali / trims / spezialteile / pièces spéciales / piezas especiales / специальные изделия

15x60	E. ELLE	2	0,18	5,16
-------	---------	---	------	------

## pezzi speciali / trims / spezialteile / pièces spéciales / piezas especiales / специальные изделия

	GRADONE* STEP TILE* 30x60	GRADONE* STEP TILE* 30x60	GRADONE* STEP TILE* 30x60	GRADONE* STEP TILE* 30x60	ALZATA RISER TILE 20x60	ALZATA RISER TILE 20x60	ALZATA RISER TILE 20x60
LAVORAZIONE LATI TAGLIO + ASSEMBLAGGIO EDGES PRODUCED BY CUTTING + ASSEMBLY	SOLO SU LATO LUNGO ON LONG SIDE ONLY	LATO LUNGO + SX LONG SIDE + L	LATO LUNGO + DX LONG SIDE + R	LATO LUNGO + DX + SX LONG SIDE + R + L	NESSUN LATO LAVORATO NO SHAPED EDGES	ENTRAMBI I LATI CORTI BOTH SHORT SIDES	DX/SX RIBALTABILE R/L REVERSIBLE
Concept XT20 Beige	R57W	R580	R584	R589	R58E	R58J	R58N
Concept XT20 Greige	R57X	R581	R585	R58A	R58F	R58K	R58P
Concept XT20 Grigio	R57Y	R582	R587	R58C	R58G	R58L	R58Q
Concept XT20 Nero	R57Z	R583	R588	R58D	R58H	R58M	R58R

	COPRI MURETTO COPING TILE 30x60	COPRI MURETTO COPING TILE 30x60	ELEMENTO ELLE* L-EDGING TILE* 15x60x4	BORDO U* U-EDGING TILE* 15x60x15	CORDOLO L* L-KERB TILE* 15x20x60	CANALINA* GUTTER TILE* 15x60x8	GRIGLIA GRID TILE 15x60
LAVORAZIONE ROMPIGOCCIA NON-DRIP EDGE	SU 2 LATI LUNGHICI ON THE 2 LONG SIDES	SU 3 LATI ON 3 SIDES					
Concept XT20 Beige	R599	R59E	R45T	R58W	R590	R58S	R594
Concept XT20 Greige	R59A	R59F	R45S	R58X	R591	R58T	R595
Concept XT20 Grigio	R59C	R59G	R45R	R58Y	R592	R58U	R597
Concept XT20 Nero	R59D	R59H	R45U	R58Z	R593	R58V	R598

Tutti i pezzi speciali sono su richiesta e sono coordinabili ai fondi rettificati. Gli imballi vengono calcolati sulla base del quantitativo ordinato.

All special pieces are supplied to order and can be matched with the rectified plain tiles. Packaging is calculated on the basis of the quantity ordered.

Alle Formteile sind auf Anfrage erhältlich und mit den rektifizierten Grundfliesen kombinierbar. Die Verpackung wird auf der Grundlage der Bestellmenge berechnet.

Toutes les pièces spéciales sont fabriquées sur demande et coordonnables aux fonds rectifiés. Les emballages sont calculés en fonction de la quantité commandée.

Todas las piezas especiales se entregan bajo pedido y se pueden coordinar con los fondos rectificados. Los embalajes se calculan según las cantidades encargadas en los pedidos.

Все специальные изделия производятся на заказ и сочетаются с обрезной фоновой плиткой. Упаковки рассчитываются на основе заказанного количества.

Per le pavimentazioni esterne non protette, Ragno consiglia di creare una pendenza  $\geq 1,5\%$  sulla superficie calpestabile allo scopo di limitare il formarsi di ristagni d'acqua localizzati. Nel caso in cui questi ristagni permangano sulla superficie delle piastrelle nonostante una posa a regola d'arte, è necessario intervenire meccanicamente con l'utilizzo di scope o aspira-liquidi. / For unprotected outdoor pavings, Ragno recommends the creation of a gradient of  $\geq 1.5\%$  on the finished surface, to prevent the formation of patches of standing water. In the event that standing water persists on the surface of the tiles in spite of correct installation, it must be removed mechanically with the aid of brooms or wet-and-dry vacuum cleaners. / Zur Unterbindung von punktueller Stauwasserbildung bei Belägen in ungeschützten Außenbereichen, empfiehlt die Ragno die Ausbildung eines Gefälles  $\geq 1,5\%$  auf der Trittlfläche. Sollte trotz fachgerechter Verlegung Stauwasser auf der Fliesenoberfläche zurückbleiben, ist dessen mechanische Entfernung mit Hilfe eines Besens oder Nasssaugers erforderlich. / Pour des sols extérieurs non protégés, Ragno conseille de créer une inclinaison  $\geq 1,5\%$  sur la surface de piétinement en vue de limiter la stagnation localisée de l'eau. Si, malgré une pose dans les règles de l'art, cette stagnation devait persister à la surface des carreaux, une intervention mécanique, au moyen de balais et d'aspirateurs de liquides, est alors nécessaire. / En el caso de pavimentaciones exteriores no protegidas, Ragno recomienda crear una pendiente  $\geq 1,5\%$  en la superficie transitable para limitar la formación de depósitos localizados de agua estancada. En caso de que estos depósitos de agua permanezcan en la superficie del azulejo, aun cuando la colocación se haya realizado correctamente, será necesario intervenir mecánicamente empleando un cepillo o un aspirador de líquidos. / Для наружных незащищенных полов Ragno рекомендует создавать уклон  $\geq 1,5\%$  на пешеходной поверхности для снижения образования локальных застоев воды. В случае, если застои воды образуются на плитке несмотря на правильную укладку, необходимо прибегать к использованию механических средств, таких как щетки или же аппараты для сбора жидкостей.



Style Book Products

**SMALL SIZES**

- Piccoli Formati*
- Small sizes*
- Kleine Formate*
- Petits formats*
- Formatos pequeños*
- Маленькие форматы*

# Contrasti

20x20



R7GT Contrasti Beige 20x20  
R7HG Contrasti Tappeto 5 20x20  
R7HL Contrasti Tappeto 8 20x20

small sizes

# Contrasti

20x20



H

R7GQ Contrasti Bianco  
20x20



G

R7GS Contrasti Grigio  
20x20

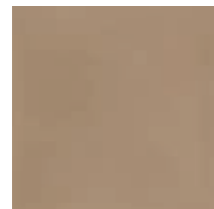

G

R7GT Contrasti Beige  
20x20



G

R7HU Contrasti Antracite  
20x20



G

R7GV Contrasti Celadon  
20x20



G

R7GW Contrasti Ottanio  
20x20



H

R7HC Contrasti Tappeto 1\*  
20x20



H

R7HD Contrasti Tappeto 2\*  
20x20



G

R7HE Contrasti Tappeto 3\*  
20x20



G

R7HF Contrasti Tappeto 4\*  
20x20



H

R7HG Contrasti Tappeto 5\*  
20x20



G

R7HH Contrasti Tappeto 6\*  
20x20



H

R7HJ Contrasti Tappeto 7\*  
20x20



G

R7HL Contrasti Tappeto 8\*  
20x20



G

R7HN Contrasti Tappeto 9\*  
20x20

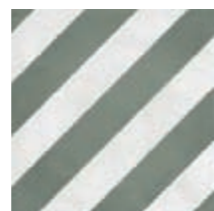

G

R7HP Contrasti Tappeto 10\*  
20x20



G

R7HQ Contrasti Tappeto 11\*  
20x20



H

R7HR Contrasti Tappeto 12\*  
20x20



G

R7HS Contrasti Tappeto 13\*  
20x20



H

R7GY Contrasti Decoro Mix Grigio\*\*  
20x20



H

R7GZ Contrasti Decoro Mix Antracite\*\*  
20x20



H

R7H4 Contrasti Decoro Mix Ottanio\*\*  
20x20

## tech info

\*

Posa 90° senso orario / 90° clockwise installation / Verband im 90-Grad-Winkel, im Uhrzeigersinn / Pose à 90° dans le sens des aiguilles d'une montre / Colocación 90° sentido de las agujas del reloj / Укладка под 90° по часовой стрелке

\*\*

16 diversi soggetti / 16 different motifs / 16 verschiedene Motive / 16 sujets différents / 16 temas diferentes / 16 различных рисунка



Apprezzabili differenze nell'aspetto di superficie e grafica all'interno della stessa produzione. / Clearly distinguishable differences in texture and pattern within the same production run. / Auffällige Unterschiede in Aussehen und Struktur innerhalb der gleichen Produktionscharge. / Différences visibles au niveau de l'aspect et de la fantaisie entre les carreaux du même lot de production. / Diferencias visibles en el aspecto de la superficie y los motivos dentro de un mismo lote de producción. / Заметные отличия вида поверхности и графики в одной и той же партии.

## imballi / packaging / verpackungen / emballages / embalajes / упаковки

Scatole / Box / Karton / Boite / Caja / Коробки      Pallet / Pallet / Palette / Palette / Pallet / Поддон



## fondi / plain tiles / grundfliesen / fonds / fondos / фоновая плитка

20x20	24	0,96	21,99	54	51,84	1187,90	10
-------	----	------	-------	----	-------	---------	----

## decori / decorative pieces / dekore / décors / decoraciones / декоры

20x20	Tappeto	24	0,96	22,22	54	51,84	1200,00	10
20x20	Decoro Mix	24	0,96	22,22	54	51,84	1200,00	10



# Abitare

20x20



R625 Abitare Grigio 20x20  
R633 Abitare Decoro Tappeto 5 20x20

# Abitare

20x20

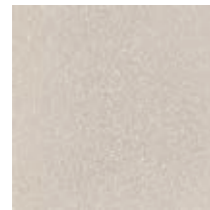

G

R62P Abitare Bianco  
20x20

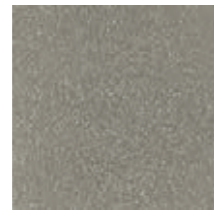

G

R625 Abitare Grigio  
20x20



H

R62T Abitare Fango  
20x20



G

R62W Abitare Antracite  
20x20



H

R62U Abitare Arancio  
20x20



G

R62V Abitare Azzurro  
20x20

Abbinabile ai fondi / Matching with colours / Mit den Grundfliesen kombinierbar / Peut s'associer aux carreaux de base de couleurs / Puede combinarse con los fondos / Сочетается с фоновой плиткой:  
Azzurro



G

R62Z Abitare Tappeto 1\*  
20x20



G

R630 Abitare Tappeto 2\*  
20x20



H

R631 Abitare Tappeto 3\*  
20x20



H

R632 Abitare Tappeto 4\*  
20x20

Abbinabile ai fondi / Matching with colours / Mit den Grundfliesen kombinierbar / Peut s'associer aux carreaux de base de couleurs / Puede combinarse con los fondos / Сочетается с фоновой плиткой:  
Bianco, Grigio

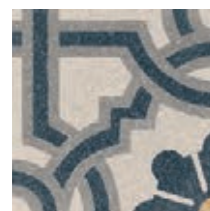

G

R633 Abitare Tappeto 5\*  
20x20

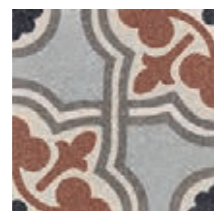

H

R634 Abitare Tappeto 6\*  
20x20



G

R635 Abitare Tappeto 7\*  
20x20

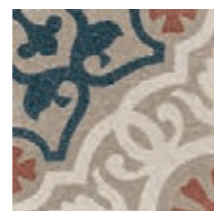

H

R637 Abitare Tappeto 8\*  
20x20



H

R639 Abitare Mix\*\*  
20x20

## tech info

\*

Posa 90° senso orario / 90° clockwise installation / Verband im 90-Grad-Winkel, im Uhrzeigersinn / Pose à 90° dans le sens des aiguilles d'une montre / Colocación 90° sentido de las agujas del reloj / Укладка под 90° по часовой стрелке

\*\*

15 diversi soggetti / 15 different motifs / 15 verschiedene Motive / 15 sujets différents / 15 temas diferentes / 15 различных рисунка



Apprezzabili differenze nell'aspetto di superficie e grafica all'interno della stessa produzione. / Clearly distinguishable differences in texture and pattern within the same production run. / Auffällige Unterschiede in Aussehen und Struktur innerhalb der gleichen Produktionscharge. / Différences visibles au niveau de l'aspect et de la fantaisie entre les carreaux du même lot de production. / Diferencias visibles en el aspecto de la superficie y los motivos dentro de un mismo lote de producción. / Заметные отличия вида поверхности и графики в одной и той же партии.

## imballi / packaging / verpackungen / emballages / embalajes / упаковки

Scatole / Box / Karton / Boite / Caja / Коробки Pallet / Pallet / Palette / Palette / Pallet / Поддон

	M <sup>2</sup>	KG		M <sup>2</sup>	KG	≠ mm
--	----------------	----	--	----------------	----	------

fondi / plain tiles / grundfliesen / fonds / fondos / фоновая плитка	20x20	24	0,96	21,46	54	51,84	1158,94	10	
decori / decorative pieces / dekore / décors / decoraciones / декоры	20x20	Tappeto	24	0,96	21,46	54	51,84	1158,94	10
	20x20	Mix	24	0,96	21,46	54	51,84	1158,94	10

# A\_Mano

20x20



R6MM A\_Mano Bianco Antico 20x20  
R6NW A\_Mano Decoro Tappeto 2 Bianco Antico  
R6MN A\_Mano Ardesia 20x20  
R6MP A\_Mano Vulcano 20x20

small sizes

# A\_Mano

20x20



G

R6MM A\_Mano Bianco Antico  
20x20

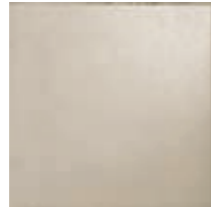

G

R6ML A\_Mano Crema  
20x20



F

R6MN A\_Mano Ardesia  
20x20

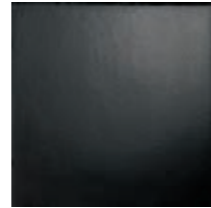

F

R6MP A\_Mano Vulcano  
20x20



F

R6NT A\_Mano Decoro Tappeto 1 Bianco Antico  
20x20



F

R6MZ A\_Mano Decoro Tappeto 1 Crema  
20x20



F

R6NU A\_Mano Decoro Tappeto 1 Ardesia  
20x20



F

R6NW A\_Mano Decoro Tappeto 2 Bianco Antico  
20x20



F

R6NV A\_Mano Decoro Tappeto 2 Crema  
20x20



F

R6NX A\_Mano Decoro Tappeto 2 Ardesia  
20x20

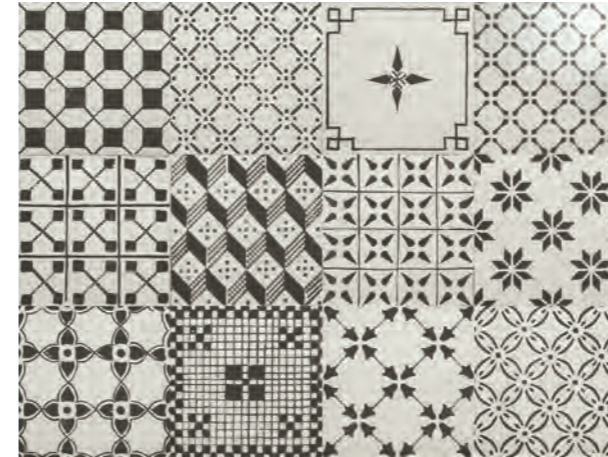

F

R6MS A\_Mano Decoro Mix Bianco Antico\*  
20x20

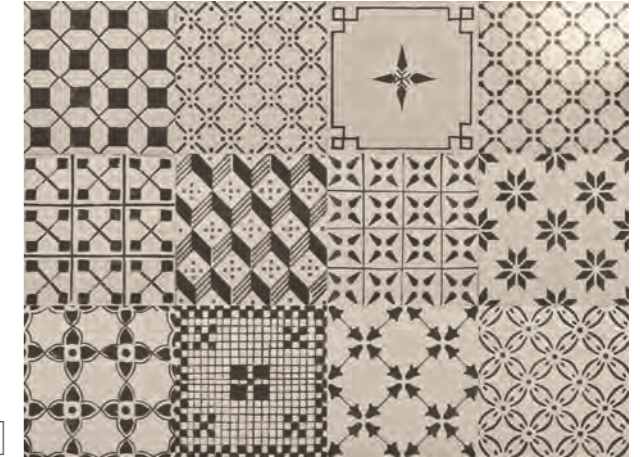

F

R6MQ A\_Mano Decoro Mix Crema\*  
20x20

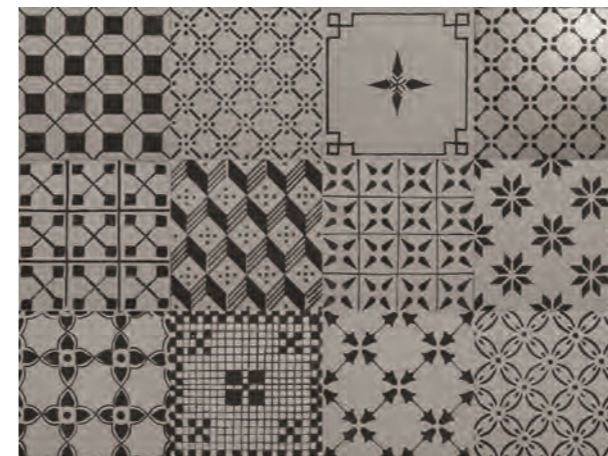

F

R6MT A\_Mano Decoro Mix Ardesia\*  
20x20

## tech info

\*  
12 diversi soggetti / 12 different motifs / 12 verschiedene Motive / 12 sujets différents /  
12 temas diferentes / 12 различных рисунка

## imballi / packaging / verpackungen / emballages / embalajes / упаковки

Scatole / Box / Karton / Pallet / Pallet / Palette /  
Boite / Caja / Коробки / Palette / Pallet / Поддон



fondi / plain tiles / grundfliesen / fonds / fondos / фоновая плитка	M²		KG		mm	
20x20	24	0,96	21	54	51,84	1048,00
decori / decorative pieces / dekore / décors / decoraciones / декоры	M²		KG		mm	
20x20	24	0,96	21	54	51,84	1048,00

# Ottocento

20x20



RKMS Ottocento Basalto 20x20  
RKMQ Ottocento Talco 20x20  
RKMR Ottocento Pomice 20x20

small sizes

# Ottocento

20x20

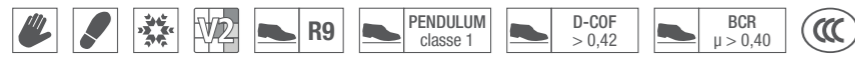

H

**RKMQ** Ottocento Talco  
20x20



H

**RKMR** Ottocento Pomice  
20x20



H

**RKMS** Ottocento Basalto  
20x20



G

**RKMM** Ottocento Cobalto  
20x20



H

**RKMP** Ottocento Ambra  
20x20



H

**RKMN** Ottocento Terra  
20x20



H

**RKMU** Ottocento Ocra  
20x20



H

**RKMT** Ottocento Cadmio  
20x20



H

**RFFW** Ottocento Decoro Mix Ambra\*  
20x20

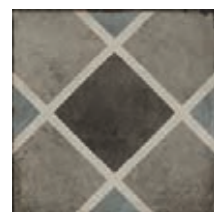

H

**R86Z** Ottocento Decoro Tappeto 1 Talco  
20x20



H

**R873** Ottocento Decoro Tappeto 2 Talco\*\*  
20x20



H

**R87A** Ottocento Decoro Tappeto 3 Talco  
20x20

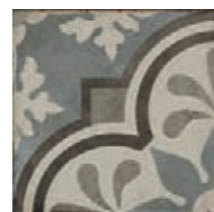

H

**R87C** Ottocento Decoro Tappeto 4 Talco\*\*  
20x20



H

**R87D** Ottocento Decoro Tappeto 5 Talco\*\*  
20x20



H

**R87E** Ottocento Decoro Tappeto 6 Talco\*\*  
20x20



H

**R87F** Ottocento Decoro Tappeto 7 Talco  
20x20



H

**R87G** Ottocento Decoro Tappeto 8 Talco\*\*  
20x20



H

**RFFX** Ottocento Decoro Mix Talco\*  
20x20

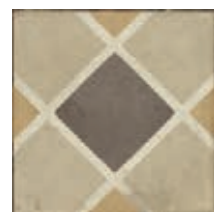

H

**R86R** Ottocento Decoro Tappeto 1 Ambra  
20x20



H

**R86S** Ottocento Decoro Tappeto 2 Ambra\*\*  
20x20



H

**R86T** Ottocento Decoro Tappeto 3 Ambra  
20x20

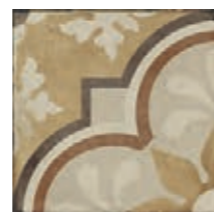

H

**R86U** Ottocento Decoro Tappeto 4 Ambra\*\*  
20x20

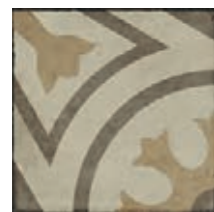

H

**R86V** Ottocento Decoro Tappeto 5 Ambra\*\*  
20x20



H

**R86W** Ottocento Decoro Tappeto 6 Ambra\*\*  
20x20



H

**R86X** Ottocento Decoro Tappeto 7 Ambra  
20x20



H

**R86Y** Ottocento Decoro Tappeto 8 Ambra\*\*  
20x20

## tech info

\*

20 diversi soggetti / 20 different motifs / 20 verschiedene Motive / 20 sujets différents / 20 temas diferentes / 20 различных рисунка

\*\*

Posa 90° senso orario / 90° clockwise installation / Verband im 90-Grad-Winkel, im Uhrzeigersinn / 2Pose à 90° dans le sens des aiguilles d'une montre / Colocación 90° sentido de las agujas del reloj / Укладка под 90° по часовой стрелке



Apprezzabili differenze nell'aspetto di superficie e grafica all'interno della stessa produzione. / Clearly distinguishable differences in texture and pattern within the same production run. / Auffällige Unterschiede in Aussehen und Struktur innerhalb der gleichen Produktionscharge. / Différences visibles au niveau de l'aspect et de la fantaisie entre les carreaux du même lot de production. / Diferencias visibles en el aspecto de la superficie y los motivos dentro de un mismo lote de producción. / Заметные отличия вида поверхности и графики в одной и той же партии.

## imballi / packaging / verpackungen / emballages / embalajes / упаковки

Scatole / Box / Karton / Boite / Caja / Коробки Pallet / Pallet / Palette / Palette / Pallet / Поддон



fondi / plain tiles / grundfliesen / fonds / fondos / фоновая плитка	20x20	24	0,96	21	54	51,84	1048,00	10
<b>decori</b> / decorative pieces / dekore / décors / decoraciones / декоры	20x20	24	0,96	21	54	51,84	1048,00	10

# Brick Glossy

10x30



R4GK Brick Glossy Beige 10x30  
R4GM Brick Glossy Blue 10x30  
R4CD Rewind Argilla 60x60

small sizes

# Brick Glossy

10x30

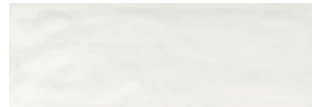

**R4GJ** Brick Glossy White  
10x30



**R4GK** Brick Glossy Beige  
10x30



**R4GL** Brick Glossy Grey  
10x30



**R4GP** Brick Glossy Decoro White  
10x30



**R4GQ** Brick Glossy Decoro Beige  
10x30

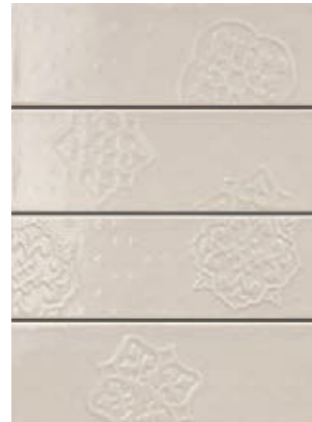

**R4GR** Brick Glossy Decoro Grey  
10x30

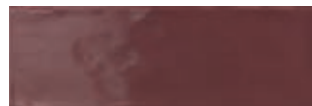

**R4JF** Brick Glossy Purple  
10x30

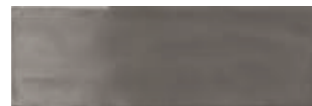

**R4JG** Brick Glossy Anthracite  
10x30

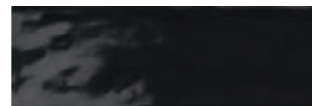

**R4GN** Brick Glossy Black  
10x30

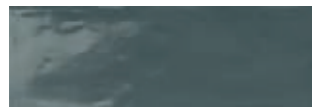

**R4GM** Brick Glossy Blue  
10x30



**R4KT** Brick Glossy Decoro Grey\*  
10x30

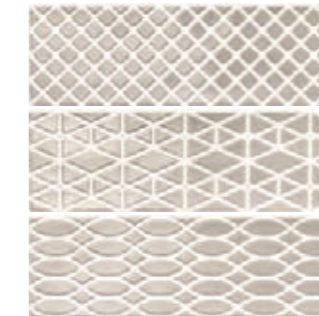

**R4KV** Brick Glossy Decoro Beige\*  
10x30

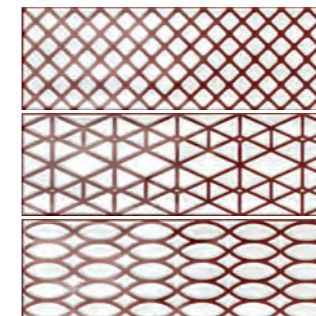

**R4KU** Brick Glossy Decoro Purple\*  
10x30

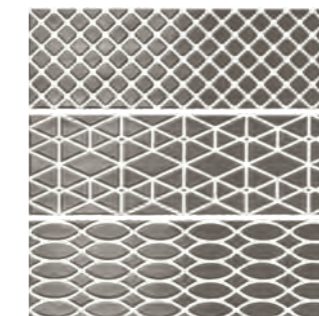

**R4KS** Brick Glossy Decoro Anthracite\*  
10x30

## tech info

- ★  
3 diversi soggetti  
3 different motifs  
3 verschiedene motive  
3 sujets différents  
3 temas diferentes  
3 различных рисунка

pezzi speciali / trims / spezialteile / pièces spéciales / piezas especiales / специальные изделия

	AL. 12,5x30	MT.C. 2,5x30
--	----------------	-----------------

Brick Glossy White	R4JH	R4JN
Brick Glossy Beige	R4JJ	R4JP
Brick Glossy Grey	-	R4JQ
Brick Glossy Anthracite	-	R4JU
Brick Glossy Black	R4JL	R4JS
Brick Glossy Blue	R4JK	R4JR
Brick Glossy Purple	R4JM	R4JT

imballi / packaging / verpackungen / emballages / embalajes / упаковки

	Scatole / Box / Karton / Boite / Caja / Коробки			Pallet / Pallet / Palette / Palette / Поддон		
	M <sup>2</sup>	KG		M <sup>2</sup>	KG	≠ mm

<b>fondi</b> / plain tiles / grundfliesen / fonds / fondos / фоновая плитка						
10x30	36	1,08	15,66	66	71,28	1033,68
10x30 decoro	33	0,99	15,46	66	65,34	1020,45
<b>decori</b> / decorative pieces / dekore / décors / decoraciones / декоры						
10x30 decoro*	6	0,18	2,47			
<b>pezzi speciali</b> / trims / spezialteile / pièces spéciales / piezas especiales / специальные изделия						
12,5x30 AL	6	0,22	1,19			
2,5x30 MT.C.	6	0,04	0,89			



# Touch

10x30



Gruppo Billa UNI EN 14411\_J

rivestimenti in pasta bianca / white bodywall tiles / wandfliesen aus weissen ton scherben / revetements en pate blanche / revestimientos en pasta blanca / облицовка из белой глины

superfici / surfaces / finitions / oberflächen / superficies / поверхности: **matt**



**R2GX** Touch White  
10x30



**R2GY** Touch Ivory  
10x30



**R2HA** Touch Brown  
10x30



**R2HX** Touch White strutturato  
10x30



**R2HY** Touch Ivory strutturato  
10x30



**R2JA** Touch Brown strutturato  
10x30

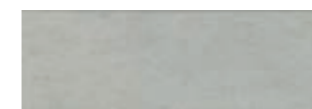

**R2GZ** Touch Silver  
10x30



**R2HC** Touch Smoke  
10x30



**R2HZ** Touch Silver strutturato  
10x30



**R2JC** Touch Smoke strutturato  
10x30

R2GX Touch White 10x30  
R2HX Touch White strutturato 10x30  
R2HC Touch Smoke 10x30  
R2JC Touch Smoke strutturato 10x30  
ROYU Jazz Black rettificato 30x60

imballi / packaging / verpackungen / emballages / embalajes / упаковки

Scatole / Box / Karton / Boite / Caja / Коробки			Pallet / Pallet / Palette / Palette / Pallet / Поддон			≠ mm
M <sup>2</sup>	KG	M <sup>2</sup>	KG			

fondi / plain tiles / grundfliesen / fonds / fondos / фоновая плитка								
10x30	36	1,08	15,17	66	71,28	999,53	7,5	
10x30	strutturato	36	1,08	17,19	66	71,28	1134,86	7,5

small sizes

# Calce

7x28

Gruppo Bia UNI EN 14411\_G

gres porcellanato / porcelain stoneware / feinsteinzeug / grès cérame émaillé / gres porcelánico / керамогранит

superfici / surfaces / finitions / oberflächen / superficies / поверхности:  
naturale/matt



R02V Calce Nero 7x28  
R56E Woodmania Ash 20x120



R02Q Calce Puro  
7x28 G



R02R Calce Panna  
7x28 G



R02S Calce Perla  
7x28 G

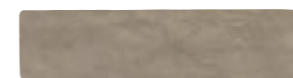

R02T Calce Nocciola  
7x28 G



R02U Calce Antracite  
7x28 G



R02V Calce Nero  
7x28 F

imballi / packaging / verpackungen / emballages / embalajes / упаковки

Scatole / Box / Karton /  
Boite / Caja / Коробки

Pallet / Pallet / Palette /  
Palette / Pallet / Поддон

	M <sup>2</sup>	KG		M <sup>2</sup>	KG	# mm
--	----------------	----	--	----------------	----	---------

fondi / plain tiles / grundfliesen / fonds / fondos / фоновая плитка

7x28	50	0,98	18,72	52	50,96	973,61	9
------	----	------	-------	----	-------	--------	---

# Eden

21x18,2 7x28



R06J Eden Cotone 7x28  
R12D Eden Decoro Tin Cotone 7x28  
R02L Epoca Cotto scuro rettificato 60x60

Gruppo BIa UNI EN 14411\_G

gres porcellanato / porcelain stoneware / feinsteinzeug / grès cérame émaillé / gres porcelánico / керамогранит

Gruppo BIII UNI EN 14411\_L

7x28 Eden Decoro Tin

rivestimenti in pasta bianca / white body wall tiles / wandfliesen aus weissen ton scherben / revêtements en pate blanche / revestimientos en pasta blanca / облицовка из белой глины

superfici / surfaces / finitions / oberflächen / superficies / поверхности: semi-matt



R06H Eden Bianco 7x28 F



R06J Eden Cotone 7x28 F



R06K Eden Greige 7x28 F



R06L Eden Fango 7x28 F

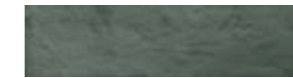

R06M Eden Ottanio 7x28 F



RGKX Eden Esagona Bianco 21x18,2 F



RGKY Eden Esagona Cotone 21x18,2 F



RGKZ Eden Esagona Greige 21x18,2 F



RGL0 Eden Esagona Fango 21x18,2 F



RGL1 Eden Esagona Ottanio 21x18,2 F



R12C Eden Decoro Tin Bianco 7x28



R12D Eden Decoro Tin Cotone 7x28

small sizes

# Eden

21x18,2 7x28



RF8N Edén Decoro Tappeto 1 Bianco  
21x18,2



RF8P Edén Decoro Tappeto 1 Cotone  
21x18,2



RF8Q Edén Decoro Tappeto 2 Bianco  
21x18,2



RF8R Edén Decoro Tappeto 2 Cotone  
21x18,2



RGL2 Edén Esagona Decoro Romance Bianco\*  
21x18,2



RGL3 Edén Esagona Decoro Romance Cotone\*  
21x18,2



Edén Cotone



## tech info

\*

12 diversi soggetti / 12 different motifs / 12 verschiedene Motive / 12 sujets différents / 12 temas diferentes / 12 различных рисунка



Significativa variazione di aspetto superficiale, grafica e colore da piastrella a piastrella e all'interno della stessa piastrella. Si consiglia di visionare la gamma cromatica prima della selezione del materiale. / Significant variation in texture, pattern and colour from tile to tile within the same production run. The colour range should be viewed before selecting the material. / Bedeutende Variation in Aussehen, Struktur und Farbe von Fliese zu Fliese und in ein und derselben Fliese. Es wird empfohlen, das Farbsortiment vor der Auswahl des Materials zu prüfen. / Variation significative au niveau de l'aspect, de la fantaisie et de la couleur entre les carreaux et au sein d'un même carreau. Il est recommandé de consulter la gamme des couleurs avant de sélectionner le matériel. / Variación considerable en el aspecto superficial, los motivos y el color entre un azulejo y otro y dentro del propio azulejo. Es aconsejable visualizar la gama cromática antes de seleccionar el material. / Значительные отличия вида поверхности, графики и цвета у разных плиток и на одной и той же плитке. Перед отбором материала рекомендуется посмотреть цветовую гамму.



Apprezzabili differenze nell'aspetto di superficie e grafica all'interno della stessa produzione. / Clearly distinguishable differences in texture and pattern within the same production run. / Auffällige Unterschiede in Aussehen und Struktur innerhalb der gleichen Produktionscharge. / Différences visibles au niveau de l'aspect et de la fantaisie entre les carreaux du même lot de production. / Diferencias visibles en el aspecto de la superficie y los motivos dentro de un mismo lote de producción. / Заметные отличия вида поверхности и графики в одной и той же партии.

imballi / packaging / verpackungen / emballages / embalajes / упаковки

Scatole / Box / Karton / Boîte / Caja / Коробки	Pallet / Pallet / Palette / Palette / Поддон	#
M <sup>2</sup>	M <sup>2</sup>	KG
KG	KG	mm

fondi / plain tiles / grundfliesen / fonds / fondos / фоновая плитка	21x18,2	7x28
	16	50
	0,46	0,98
	9,64	19,42
	100	52
	45,86	50,96
	963,88	1009,77
	9,5	9
decori / decorative pieces / dekore / décors / decoraciones / декоры		
21x18,2 decoro	16	50
	0,46	0,98
	9,64	19,42
	100	52
	45,86	50,96
	963,88	1009,77
	9,5	9
7x28 decoro	8	50
	0,16	0,98
	8,17	19,42

# Fornace

7x28



R4WN Fornace Rosso 7x28  
R4KM Rewind Polvere rettificato 90x90  
R4HP Rewind XT20 Polvere rettificato 60x60



R4WL Fornace Beige  
7x28



R4WN Fornace Rosso  
7x28



R4WM Fornace Tortora  
7x28



## tech info

Per le pavimentazioni esterne non protette, Ragno consiglia di creare una pendenza  $\geq 1,5\%$  sulla superficie calpestabile allo scopo di limitare il formarsi di ristagni d'acqua localizzati. Nel caso in cui questi ristagni permangano sulla superficie delle piastrelle nonostante una posa a regola d'arte, è necessario intervenire meccanicamente con l'utilizzo di scope o aspira-liquidi. / For unprotected outdoor pavings, Ragno recommends the creation of a gradient of  $\geq 1.5\%$  on the finished surface, to prevent the formation of patches of standing water. In the event that standing water persists on the surface of the tiles in spite of correct installation, it must be removed mechanically with the aid of brooms or wet-and-dry vacuum cleaners. / Zur Unterbindung von punktueller Stauwasserbildung bei Belägen in ungeschützten Außenbereichen, empfiehlt die Ragno die Ausbildung eines Gefälles  $\geq 1,5\%$  auf der Trittläche. Sollte trotz fachgerechter Verlegung Stauwasser auf der Fliesenoberfläche zurückbleiben, ist dessen mechanische Entfernung mit Hilfe eines Besens oder Nasssaugers erforderlich. / Pour des sols extérieurs non protégés, Ragno conseille de créer une inclinaison  $\geq 1,5\%$  sur la surface de piétinement en vue de limiter la stagnation localisée de l'eau. Si, malgré une pose dans les règles de l'art, cette stagnation devait persister à la surface des carreaux, une intervention mécanique, au moyen de balais et d'aspirateurs de liquides, est alors nécessaire. / En el caso de pavimentaciones exteriores no protegidas, Ragno recomienda crear una pendiente  $\geq 1,5\%$  en la superficie transitabile para limitar la formación de depósitos localizados de agua estancada. En caso de que estos depósitos de agua permanezcan en la superficie del azulejo, aun cuando la colocación se haya realizado correctamente, será necesario intervenir mecánicamente empleando un cepillo o un aspirador de líquidos. / Для наружных незащищенных полов Ragno рекомендует создавать уклон  $\geq 1,5\%$  на пешеходной поверхности для снижения образования локальных застоев воды. В случае, если застои воды образуются на плитке несмотря на правильную укладку, необходимо прибегать к использованию механических средств, таких как щетки или же аппараты для сбора жидкостей.



Variazioni irregolari da piastrella a piastrella. Una piastrella può differire totalmente nell'aspetto superficiale e colore da un'altra. Si consiglia di visionare la gamma cromatica prima della selezione del materiale. / Random differences from tile to tile. One tile may have totally different texture and colour from another. The colour range should be viewed before selecting the material. / Wesentliche Variationen von Fliese zu Fliese. Eine Fliese kann sich in Aussehen und Farbe komplett von einer anderen unterscheiden. Es wird empfohlen, das Farbsortiment vor der Auswahl des Materials zu prüfen. / Variations irrégulières entre les carreaux. L'aspect et la couleur peuvent être complètement différents d'un carreau à l'autre. Il est recommandé de consulter la gamme des couleurs avant de sélectionner le matériel. / Variaciones irregulares entre un azulejo y otro. Un azulejo puede ser completamente diferente de otro en el aspecto superficial y el color. Es aconsejable visualizar la gama cromática antes de seleccionar el material. / Неоднородные изменения на разных плитках. Каждая плитка может полностью отличаться по виду поверхности и цвету от другой. Перед отбором материала рекомендуется просмотреть цветовую гамму.

imballi / packaging / verpackungen / emballages / embalajes / упаковки

Scatole / Box / Karton / Boite / Caja / Коробки Pallet / Pallet / Palette / Palette / Pallet / Поддон



fondi / plain tiles / grundfliesen / fonds / fondos / фоновая плитка

7x28	50	0,98	18,13	52	50,96	942,66	9
------	----	------	-------	----	-------	--------	---

# Unitech

20x20 10x30 10x10



R1QA Unitech Topazio 20x20 pav. R10 B

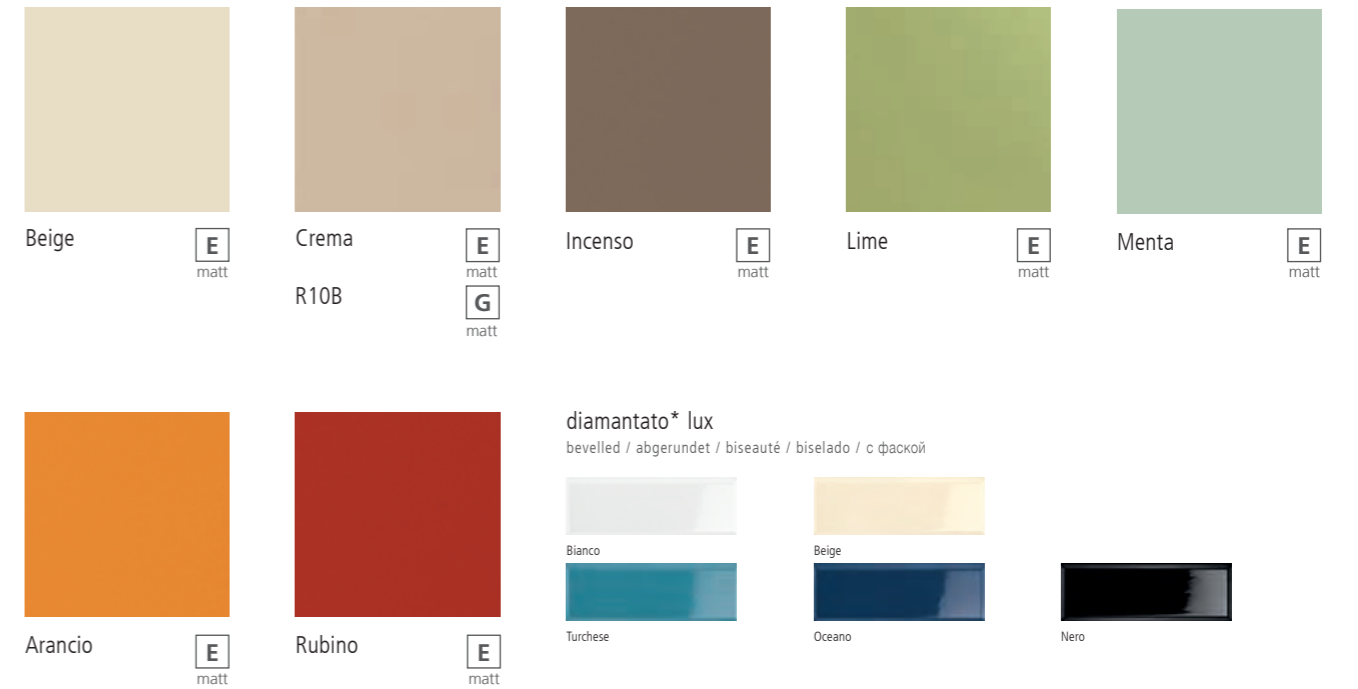
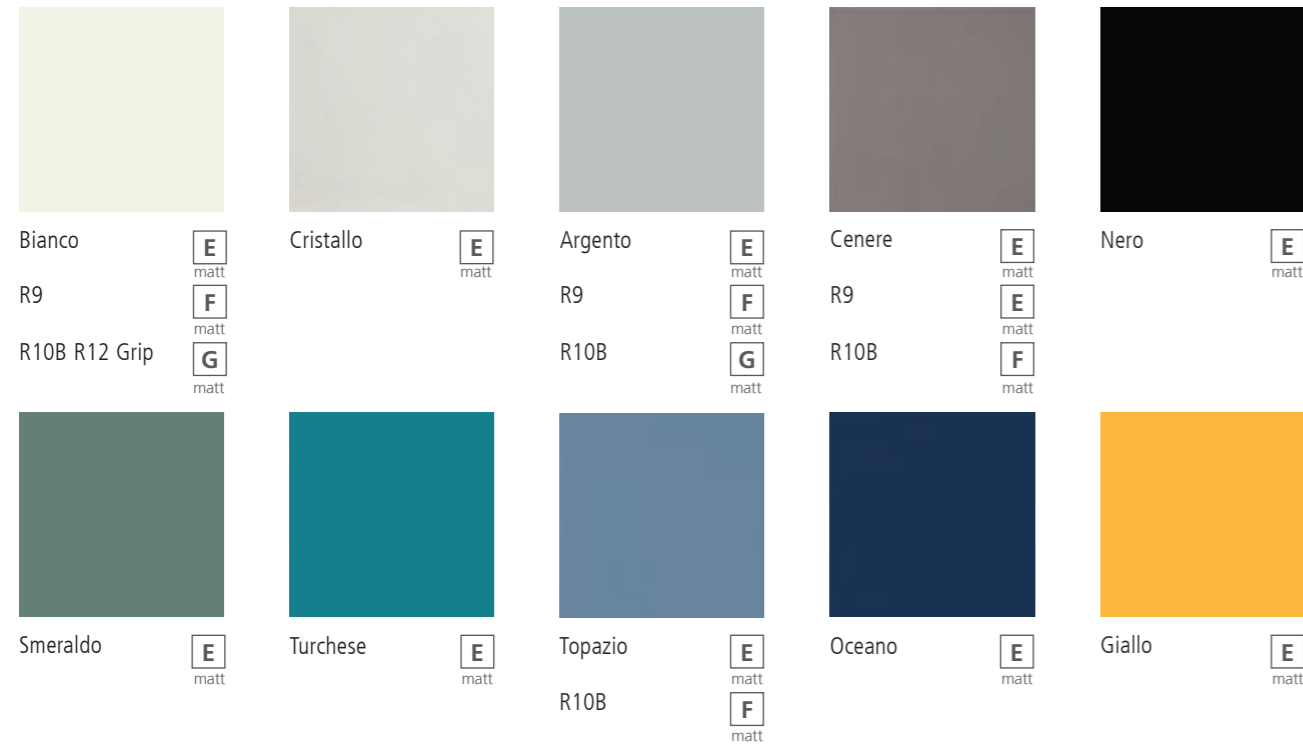

**gamma cromatica / colour range / farbpalette / gamme chromatique / gama de colores / гамма цветов**

	20x20	20x20	10x10	10x10 PC	10x10	10x10 PC	10x30	10x30	10x30 Diamantato	20x20 R9	20x20 Grip R10 B	10x10 Grip R12	10x10 Grip R12 PC
Bianco	OT98	RN46	4Y29	4Y39	94D9	94F1	R1U8	R1UT	R1TW	R1PG	R1PY	94G4	94H0
Cristallo	R1PF	R1NO											
Argento	R1PC	R1NL			R1QH		R1U9	R1UU		R1PS	R1PZ		
Cenere	OT96	RN50								R1PW	R1QD		
Nero	OT97	RN51			94E2		R1UA	R1UV	R1TX				
Beige	R1PA	R1NJ					R1UB	R1UW	R1TY				
Crema	R1PD	R1NM									R1QC		
Incenso		R1NZ						R1UX					
Lime	R1PE	R1NN					R1UD	R1UZ					
Menta	R1PK	R1NT											
Smeraldo	R1PN	R1NW											
Turchese	R1PP	R1NX					R1UE	R1V0	R1U5				
Topazio	R1PM	R1NV									R1QA		
Oceano		R1NR					R1UF	R1VA	R1U7				
Giallo	R1PH	R1NQ					R1UG	R1VB					
Arancio	R1PB	R1NK											
Rubino	R1PQ	R1NY					R1UI	R1VC					

**tech info**

★

Struttura a rilievo di spessore complessivo 9 mm, abbinabile al formato 10x30 Lux di spessore 7,5 mm / Relief texture with a total thickness of 9 mm; can be used along with the 7.5 mm thick 10x30 lux size / Reliefstruktur mit einer Gesamtstärke von 9 mm passend zum Format 10x30 lux mit 7,5 mm Stärke / Structure en relief d'une épaisseur totale de 9 mm pouvant être associée au format 10x30 lux de 7,5 mm d'épaisseur / Estructura en relieve de espesor total 9 mm combinable con el formato 10x30 lux de 7,5 mm de espesor / Рельефная структура общей толщиной 9 мм, сочетаемая с форматом 10x30 люкс толщиной 7,5 мм.

**imballi / packaging / verpackungen / emballages / embalajes / упаковки**

Scatole / Box / Karton / Boite / Caja / Коробки Pallet / Pallet / Palette / Palette / Palette / Поддон

	M <sup>2</sup>	KG	M <sup>2</sup>	KG	≠ mm	Gruppo EN
--	----------------	----	----------------	----	------	-----------

	Bianco	Cenere	Topazio				
BTS. 10x20	9889	9888	R1RH				
CNE. 3x20	8523						
CNI. 3x20	8527						
AE. 3x10	R1RD						
AI. 3x10	R1RS						
PI. 3x3	R1RS						
UI. 3x3	8515						
UE. 3x3	R1RU						

fondi / plain tiles / grundfliesen / fonds / fondos / фоновая плитка								
20x20 matt / lux	35	1,40	17,90	75	105,00	1342,00	7,2	Bill EN14411_L
10x10 lux	100	1,00	13,10	72	72,00	943,15	7	Bill EN14411_K
10x10 lux PC	96	1,00	12,96	66	66,02	855,64	7	Bill EN14411_K
10x10	100	1,00	12,10	72	72,00	871,25	7	Blla EN14411_J
10x10 PC	96	1,00	12,96	66	66,02	855,64	7	Blla EN14411_J
10x30 lux	34	1,02	13,96	66	67,32	921,43	7,5	Bill EN14411_K
10x30	36	1,08	16,87	66	71,28	1113,58	7,5	Bill EN14411_K
10x30 diamantato	28	0,84	14,80	66	55,44	976,91	9*	Bill EN14411_L
20x20 R9	30	1,20	20,28	54	64,80	1095,15	8	Bill EN14411_H
20x20 Grip R10 B	30	1,20	20,28	54	64,80	1095,15	8	Bill EN14411_H
10x10 Grip R12	100	1,00	12,10	72	72,00	871,25	7	Blla EN14411_J
10x10 Grip R12 PC	96	1,00	12,96	66	66,02	855,64	7	Blla EN14411_J

pezzi speciali / trims / spezialteile / pièces spéciales / piezas especiales / специальные изделия								
10x20 BTS.	25	-	9,87	-	-	-	7,5	Bill EN14411_L
3x20 CNE.	10	0,06 ml	0,90	-	-	-	-	Bill EN14411_L
3x20 CNI.	10	0,06 ml	0,90	-	-	-	-	Bill EN14411_L
3x10 AE.	10	0,03 ml	14,00	-	-	-	-	Bill EN14411_L
3x10 AI.	10	0,03 ml	14,00	-	-	-	-	Bill EN14411_L
3x3 PI.	10	0,01 ml	0,10	-	-	-	-	Bill EN14411_L
3x3 UI.	10	0,01 ml	0,10	-	-	-	-	Bill EN14411_L
3x3 UE.	10	0,01 ml	0,10	-	-	-	-	Bill EN14411_L



## WALL TILES

- Rivestimenti*
- Wall tiles*
- Wandfliesen*
- Revêtements*
- Revestimientos*
- Настенная плитка*



# Resina

40x120



R7LL Resina Mosaico Forme Rosa 40x43

# Resina

40x120



struttura

rivestimenti in pasta bianca - rettificato / white bodywall tiles - rectified / wandfliesen aus weissen ton scherben - rektifiziert / revetements en pate blanche - rectifié / revestimientos en pasta blanca - rectificado / облицовка из белой глины - ректифицируемый

superfici / surfaces / finitions / oberflächen / superficies / поверхности: **mat**



SLIM  
6.0 mm

**R79U** Resina Bianco rettificato  
40x120



SLIM  
6.0 mm

**R79Y** Resina Avorio rettificato  
40x120



SLIM  
6.0 mm

**R79V** Resina Grigio rettificato  
40x120

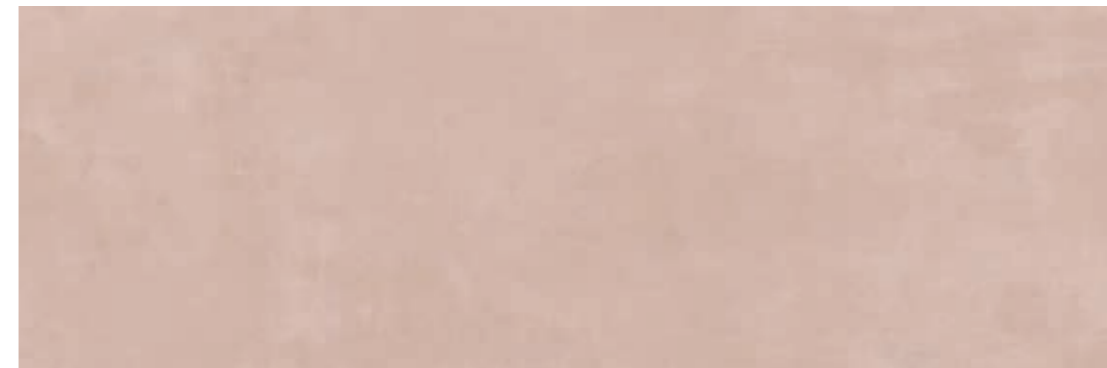

SLIM  
6.0 mm

**R79W** Resina Rosa rettificato  
40x120

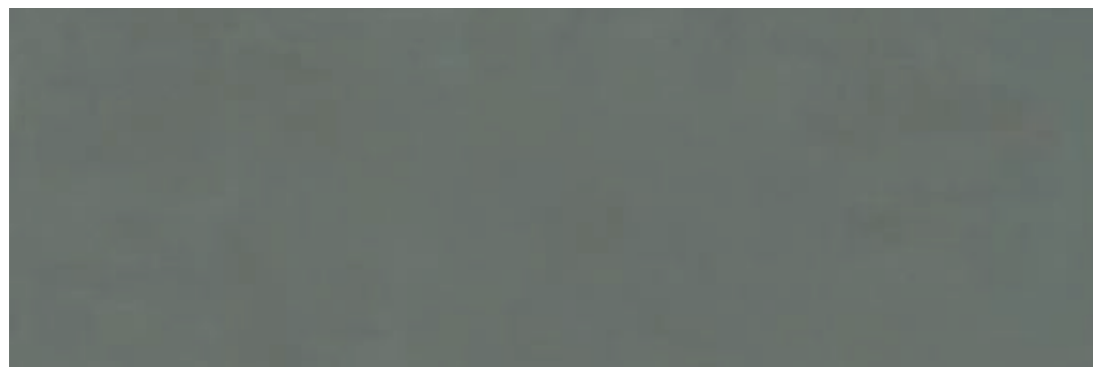

SLIM  
6.0 mm

**R79X** Resina Ardesia rettificato  
40x120

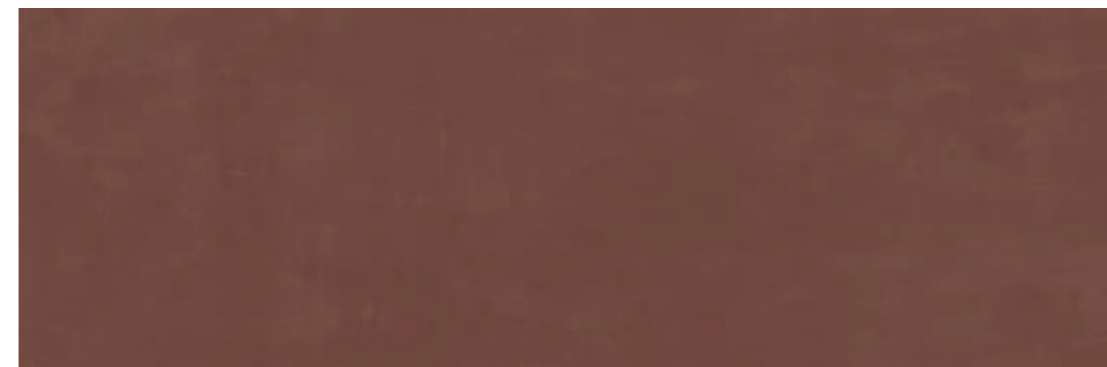

SLIM  
6.0 mm

**R79Z** Resina Terracotta rettificato  
40x120

# Resina

40x120

rivestimenti in pasta bianca - rettificato / white bodywall tiles - rectified / wandfliesen aus weissen ton scherben - rektifiziert / revetements en pate blanche - rectifié / revestimientos en pasta blanca - rectificado / облицовка из белой глины - ректифицируемый

superfici / surfaces / finitions / oberflächen / superficies / поверхности:  
**matt**



SLIM  
8,0 mm

**R79M** Resina Bianco Struttura Bee 3D rettificato  
40x120



SLIM  
8,0 mm

**R79R** Resina Avorio Struttura Bee 3D rettificato  
40x120



SLIM  
8,0 mm

**R79N** Resina Grigio Struttura Bee 3D rettificato  
40x120

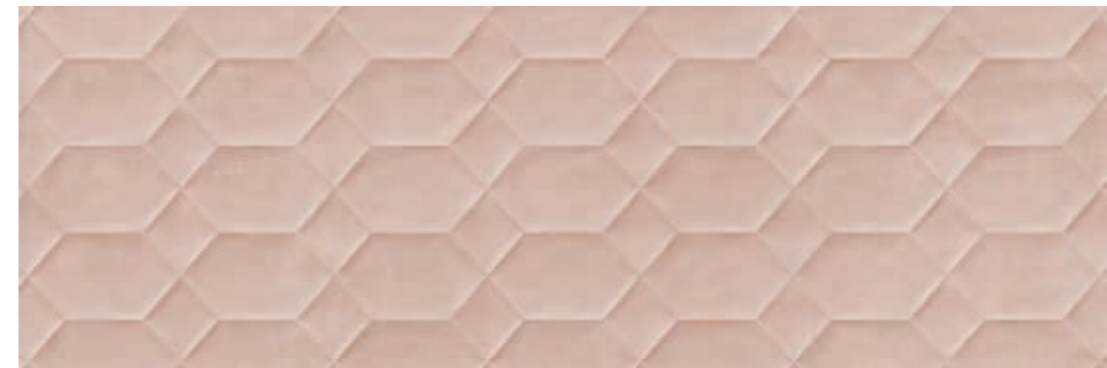

SLIM  
8,0 mm

**R79P** Resina Rosa Struttura Bee 3D rettificato  
40x120

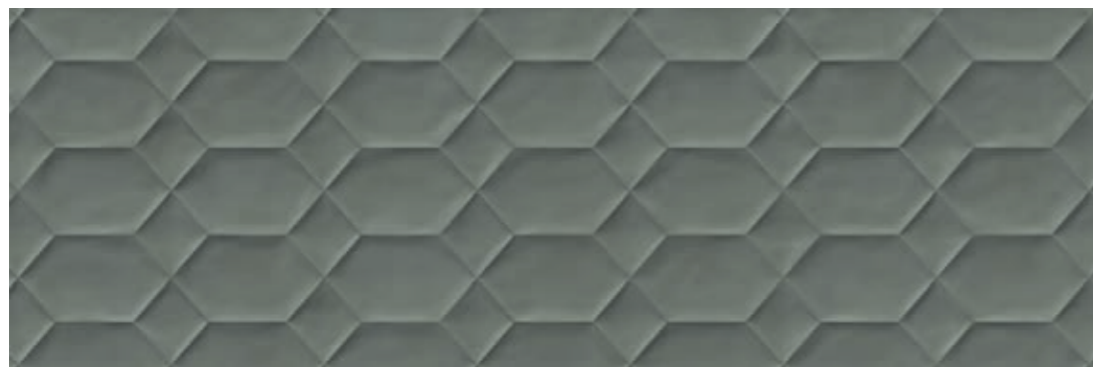

SLIM  
8,0 mm

**R79Q** Resina Ardesia Struttura Bee 3D rettificato  
40x120

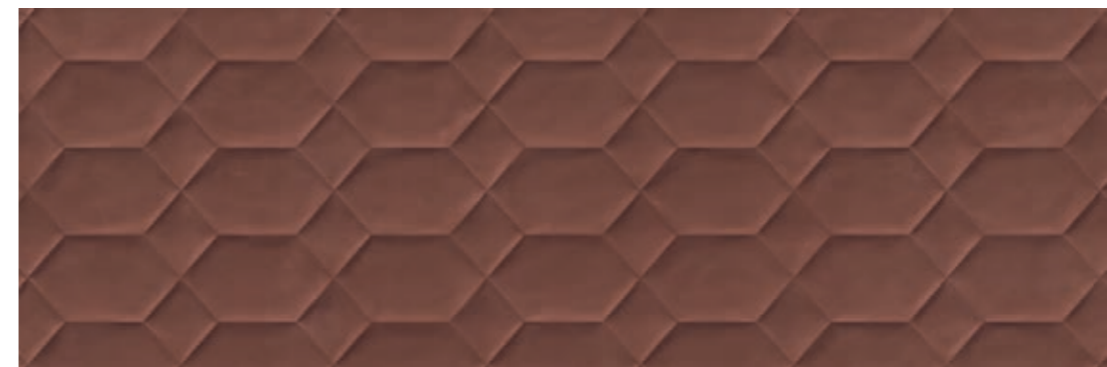

SLIM  
8,0 mm

**R79S** Resina Terracotta Struttura Bee 3D rettificato  
40x120

# Resina

40x120

rivestimenti in pasta bianca - rettificato / white bodywall tiles - rectified / wandfliesen aus weissen ton scherben - rektifiziert / revetements en pate blanche - rectifié / revestimientos en pasta blanca - rectificado / облицовка из белой глины - ректифицируемый

superfici / surfaces / finitions / oberflächen / superficies / поверхности:  
**matt**



SLIM  
8,0 mm

**R79E** Resina Bianco Struttura Wall 3D rettificato  
40x120



SLIM  
8,0 mm

**R79K** Resina Avorio Struttura Wall 3D rettificato  
40x120



SLIM  
8,0 mm

**R79F** Resina Grigio Struttura Wall 3D rettificato  
40x120



SLIM  
8,0 mm

**R79G** Resina Rosa Struttura Wall 3D rettificato  
40x120



SLIM  
8,0 mm

**R79H** Resina Ardesia Struttura Wall 3D rettificato  
40x120

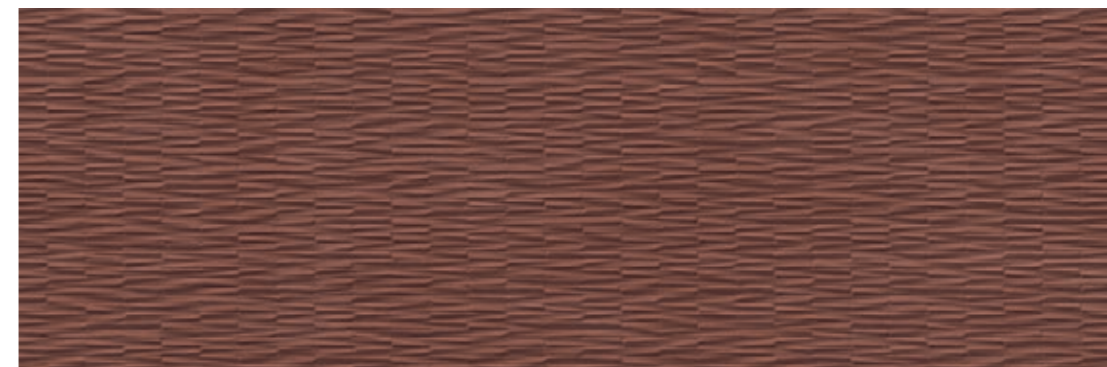

SLIM  
8,0 mm

**R79J** Resina Terracotta Struttura Wall 3D rettificato  
40x120

# Resina

40x120

Abbinabile ai fondi / Matching with colours / Mit den Grundfliesen kombinierbar / Peut s'associer aux carreaux de base de couleurs /  
Puede combinarse con los fondos / Сочетается с фоновой плиткой:

Bianco, Grigio, Ardesia



**R7AD** Resina Decoro Bricks Bianco  
40x120

Abbinabile ai fondi / Matching with colours / Mit den Grundfliesen kombinierbar / Peut s'associer aux carreaux de base de couleurs /  
Puede combinarse con los fondos / Сочетается с фоновой плиткой:

Avorio, Rosa, Terracotta



**R7AA** Resina Decoro Bricks Avorio  
40x120

**rivestimenti in pasta bianca - rettificato** / white bodywall tiles - rectified / wandfliesen aus weissen ton scherben - rektifiziert / revetements en pate blanche - rectifié /  
revestimientos en pasta blanca - rectificado / облицовка из белой глины - ректифицируемый

**superfici** / surfaces / finitions / oberflächen / superficies / поверхности:  
**matt**

Abbinabile ai fondi / Matching with colours / Mit den Grundfliesen kombinierbar / Peut s'associer aux carreaux de base de couleurs /  
Puede combinarse con los fondos / Сочетается с фоновой плиткой:

Bianco, Grigio, Ardesia



**R8CC** Resina Decoro Venezia Bianco\*  
40x120

Abbinabile ai fondi / Matching with colours / Mit den Grundfliesen kombinierbar / Peut s'associer aux carreaux de base de couleurs /  
Puede combinarse con los fondos / Сочетается с фоновой плиткой:

Avorio, Rosa, Terracotta



**R8CA** Resina Decoro Venezia Avorio\*  
40x120

Abbinabile ai fondi / Matching with colours / Mit den Grundfliesen kombinierbar / Peut s'associer aux carreaux de base de couleurs /  
Puede combinarse con los fondos / Сочетается с фоновой плиткой:

Bianco, Rosa, Terracotta, Ardesia



**R7RQ** Resina Decoro Tropicana  
80x120

# Resina

40x120

rivestimenti in pasta bianca - rettificato / white bodywall tiles - rectified / wandfliesen aus weissen ton scherben - rektifiziert / revetements en pate blanche - rectifié / revestimientos en pasta blanca - rectificado / облицовка из белой глины - ректифицируемый

superfici / surfaces / finitions / oberflächen / superficies / поверхности  
matt



**R7LN** Resina Mosaico Forme Bianco  
40x43



**R7LM** Resina Mosaico Forme Avorio  
40x43

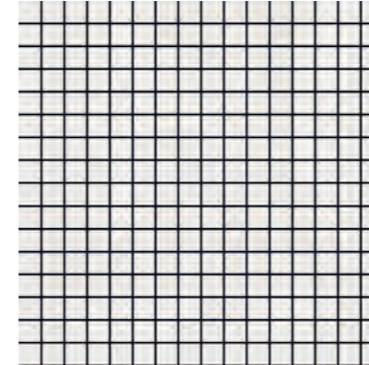

**R7LW** Resina Mosaico Bianco  
40x40

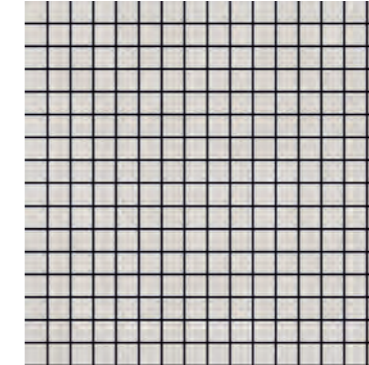

**R7LX** Resina Mosaico Grigio  
40x40

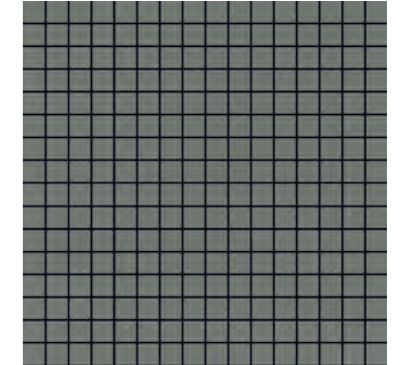

**R7LY** Resina Mosaico Ardesia  
40x40



**R7LQ** Resina Mosaico Forme Grigio  
40x43

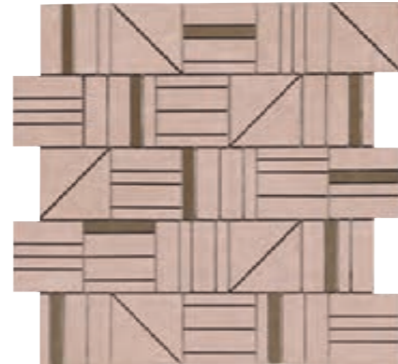

**R7LL** Resina Mosaico Forme Rosa  
40x43

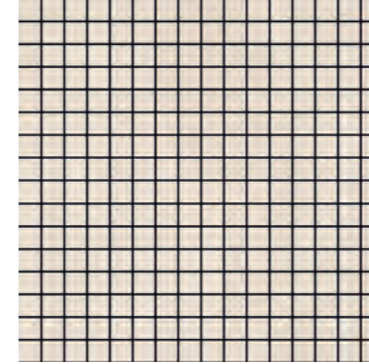

**R7LV** Resina Mosaico Avorio  
40x40

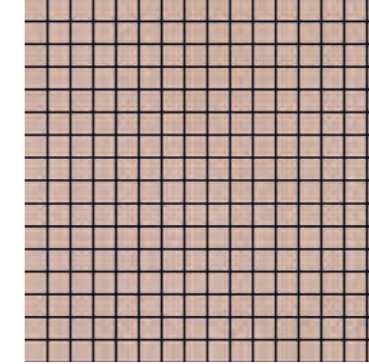

**R7LU** Resina Mosaico Rosa  
40x40

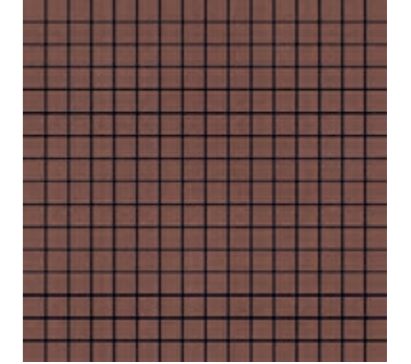

**R7LT** Resina Mosaico Terracotta  
40x40



**R7LR** Resina Mosaico Forme Ardesia  
40x43



**R7LK** Resina Mosaico Forme Terracotta  
40x43

**R7RK** Resina Listello Ossido  
0,5x120

## tech info



Mosaico assemblato su rete in fibra di vetro  
Mosaic mesh - mounted on fibreglass  
Auf Glasfasernetz geklebtes Mosaik  
Mosaïque montée sur filet en fibre de verre  
Mosaico enmallado sobre fibra de vidrio  
Мозаика, собранная на сетке из стекловолокну

## \*

Decoro con lustri/metalli preziosi utilizzabile a rivestimento; si consiglia la pulizia con detersivi neutri, non abrasivi. È sconsigliata la posa nell'area doccia. / Decors with lustres/precious metals used for covering; we recommend cleaning with neutral, non-abrasive detergents. Tiles should not be installed in the shower area. / Dekor mit Glanzelementen/Edelmetallen für die Wandverkleidung; es wird die Reinigung mit neutralen, scheuermittelfreien Reinigungsmitteln empfohlen. Die Verlegung in der Duschnische wird nicht empfohlen. / Décor avec lustres/métaux précieux à poser sur le mur. Lavage recommandé avec des détergents neutres, non abrasifs. Pose déconseillée dans la douche. / Decoración con elementos brillantes/metales preciosos utilizable para revestir superficies; se recomienda limpiarla con detergentes neutros, no abrasivos. Se desaconseja colocarla en el área de la ducha. / Декор с блестящим покрытием/драгоценными металлами, используемый для облицовки; рекомендуется чистка с использованием нейтральных, неабразивных моющих средств. Не рекомендуется укладка в душевой зоне.

## imballi / packaging / verpackungen / emballages / embalajes / упаковки

Scatole / Box / Karton / Boite / Caja / Коробки  
Pallet / Pallet / Palette / Palette / Поддон



## fondi / plain tiles / grundfliesen / fonds / fondos / фоновая плитка

Size	Structure	Box	Box Weight	Pallet	Pallet Weight	Area	Height
40x120	rettificato	6	2,88	30,79	16	46,08	492,73
40x120	struttura Bee 3D rett.	5	2,40	26,59	16	38,40	425,44
40x120	struttura Wall 3D rett.	5	2,40	28,39	16	38,40	454,33

## decori / decorative pieces / dekore / décors / decoraciones / декоры

Size	Decor	Box	Box Weight	Pallet	Pallet Weight	Area	Height
40x120	decoro Bricks	6	2,88	30,00			
40x120	decoro Venezia	4	1,92	21,05			
80x120	decoro Tropicana	1	0,96	11,00			
40x43	mosaico Forme	4	0,69	9,00	40	27,52	360,00
40x40	mosaico	4	0,64	9,00	60	38,40	540,01
0,5x120	listello	6	0,04	2,00			

# Cocciopesto

40x120



R5UX Cocciopesto Decoro Caleido Bianco 40x120



SLIM 6,0 mm

R5T2 Cocciopesto Bianco rettificato  
40x120



SLIM 6,0 mm

R5T1 Cocciopesto Grigio rettificato  
40x120

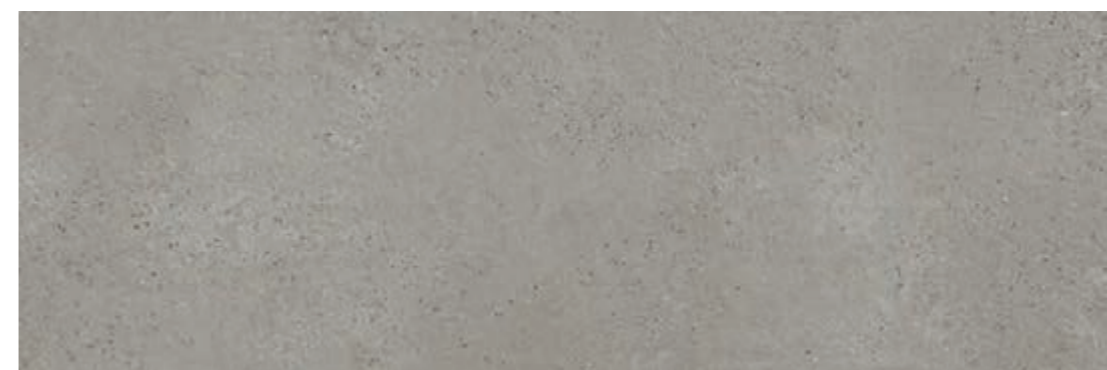

SLIM 6,0 mm

R5T0 Cocciopesto Antracite rettificato  
40x120

# Cocciopesto

40x120

Gruppo BIII UNI EN 14411\_L

rivestimenti in pasta bianca - rettificato / white bodywall tiles - rectified / wandfliesen aus weissen ton scherben - rektifiziert / revetements en pate blanche - rectifié / revestimientos en pasta blanca - rectificado / облицовка из белой глины - ректифицируемый

superfici / surfaces / finitions / oberflächen / superficies / поверхности:  
**mat**



SLIM  
6,0 mm

**R5T3** Cocciopesto Avorio rettificato  
40x120



SLIM  
8,0 mm

**R5T4** Cocciopesto Bianco Struttura Arena 3D rettificato  
40x120



SLIM  
6,0 mm

**R5T9** Cocciopesto Cotto rettificato  
40x120



SLIM  
8,0 mm

**R5T5** Cocciopesto Grigio Struttura Arena 3D rettificato  
40x120



SLIM  
8,0 mm

**R5T6** Cocciopesto Avorio Struttura Arena 3D rettificato  
40x120



# Cocciopesto

40x120

Gruppo BIII UNI EN 14411\_L

rivestimenti in pasta bianca - rettificato / white bodywall tiles - rectified / wandfliesen aus weissen ton scherben - rektifiziert / revetements en pate blanche - rectifié / revestimientos en pasta blanca - rectificado / облицовка из белой глины - ректифицируемый

superfici / surfaces / finitions / oberflächen / superficies / поверхности:  
**mat**



SLIM  
8,0 mm

**R6ZL** Cocciopesto Bianco Struttura Class 3D rettificato  
40x120



SLIM  
8,0 mm

**R6ZJ** Cocciopesto Avorio Struttura Class 3D rettificato  
40x120



SLIM  
8,0 mm

**R6ZK** Cocciopesto Grigio Struttura Class 3D rettificato  
40x120



SLIM  
8,0 mm

**R6ZG** Cocciopesto Cotto Struttura Class 3D rettificato  
40x120



SLIM  
8,0 mm

**R6ZH** Cocciopesto Antracite Struttura Class 3D rettificato  
40x120

# Cocciopesto

40x120

Gruppo BIII UNI EN 14411\_L

rivestimenti in pasta bianca - rettificato / white bodywall tiles - rectified / wandfliesen aus weissen ton scherben - rektifiziert / revetements en pate blanche - rectifié / revestimientos en pasta blanca - rectificado / облицовка из белой глины - ректифицируемый

superfici / surfaces / finitions / oberflächen / superficies / поверхности:  
**matt**

Abbinabile ai fondi / Matching with colours / Mit den Grundfliesen kombinierbar / Peut s'associer aux carreaux de base de couleurs / Puede combinarse con los fondos / Сочетается с фоновой плиткой:

Bianco, Grigio, Antracite



**R5UX** Cocciopesto Decoro Caleido Bianco  
40x120

Abbinabile ai fondi / Matching with colours / Mit den Grundfliesen kombinierbar / Peut s'associer aux carreaux de base de couleurs / Puede combinarse con los fondos / Сочетается с фоновой плиткой:

Bianco



**R6TM** Cocciopesto Decoro Opera Bianco\*  
40x120

Abbinabile ai fondi / Matching with colours / Mit den Grundfliesen kombinierbar / Peut s'associer aux carreaux de base de couleurs / Puede combinarse con los fondos / Сочетается с фоновой плиткой:

Avorio, Cotto



**R5UY** Cocciopesto Decoro Caleido Avorio  
40x120

Abbinabile ai fondi / Matching with colours / Mit den Grundfliesen kombinierbar / Peut s'associer aux carreaux de base de couleurs / Puede combinarse con los fondos / Сочетается с фоновой плиткой:

Avorio



**R6TN** Cocciopesto Decoro Opera Avorio\*  
40x120

# Cocciopesto

40x120

rivestimenti in pasta bianca - rettificato / white bodywall tiles - rectified / wandfliesen aus weissen ton scherben - rektifiziert / revetements en pate blanche - rectifié / revestimientos en pasta blanca - rectificado / облицовка из белой глины - ректифицируемый

superfici / surfaces / finitions / oberflächen / superficies / поверхности:  
**matt**

Abbinabile ai fondi / Matching with colours / Mit den Grundfliesen kombinierbar / Peut s'associer aux carreaux de base de couleurs / Puede combinarse con los fondos / Сочетается с фоновой плиткой:

Bianco



**R6XM** Cocciopesto Decoro Botanico Bianco  
40x120

Abbinabile ai fondi / Matching with colours / Mit den Grundfliesen kombinierbar / Peut s'associer aux carreaux de base de couleurs / Puede combinarse con los fondos / Сочетается с фоновой плиткой:

Avorio

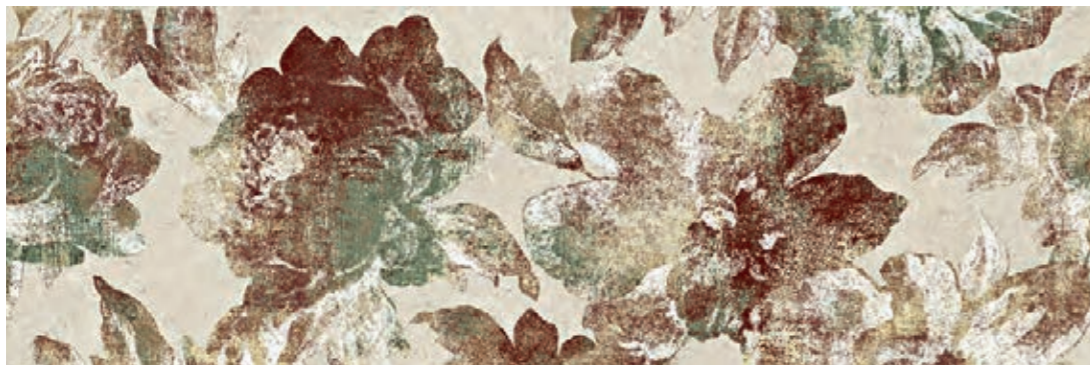

**R6XP** Cocciopesto Decoro Botanico Avorio  
40x120

**R6TA** Cocciopesto Listello Metallo ossidato  
0,5x120

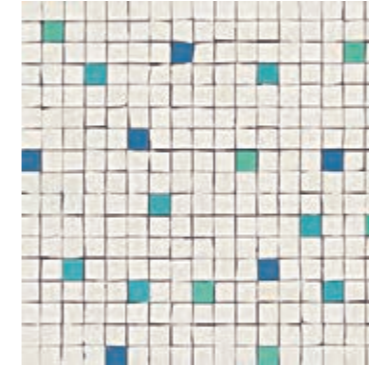

**R6TS** Cocciopesto Mosaico Bianco  
40x40

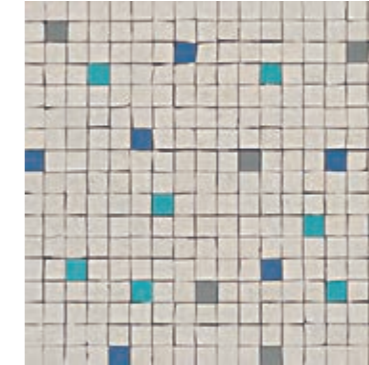

**R6TR** Cocciopesto Mosaico Grigio  
40x40



**R6TQ** Cocciopesto Mosaico Antracite  
40x40



**R6TT** Cocciopesto Mosaico Avorio  
40x40

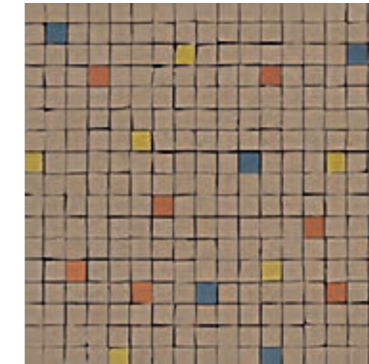

**R6TV** Cocciopesto Mosaico Cotto  
40x40

## tech info



Mosaico assemblato su rete in fibra di vetro  
Mosaic mesh - mounted on fibreglass  
Auf Glasfasernetz geklebtes Mosaik  
Mosaïque montée sur filet en fibre de verre  
Mosaico enmallado sobre fibra de vidrio  
Мозаика, собранная на сетке из стекловолокну

### \*

Decoro con lustri/metalli preziosi utilizzabile a rivestimento; si consiglia la pulizia con detergenti neutri, non abrasivi. È sconsigliata la posa nell'area doccia. / Decors with lustres/precious metals used for covering; we recommend cleaning with neutral, non-abrasive detergents. Tiles should not be installed in the shower area. / Dekor mit Glanzelementen/Edelmetallen für die Wandverkleidung; es wird die Reinigung mit neutralen, scheuermittelfreien Reinigungsmitteln empfohlen. Die Verlegung in der Duschnische wird nicht empfohlen. / Décor avec lustres/métaux précieux à poser sur le mur. Lavage recommandé avec des détergents neutres, non abrasifs. Pose déconseillée dans la douche. / Decoración con elementos brillantes/metales preciosos utilizable para revestir superficies; se recomienda limpiarla con detergentes neutros, no abrasivos. Se desaconseja colocarla en el área de la ducha. / Декор с блестящим покрытием/драгоценными металлами, используемый для облицовки; рекомендуется чистка с использованием нейтральных, неабразивных моющих средств. Не рекомендуется укладка в душевой зоне.

## imballi / packaging / verpackungen / emballages / embalajes / упаковки

Scatole / Box / Karton / Boite / Caja / Коробки Pallet / Pallet / Palette / Palette / Pallet / Поддон



fondi / plain tiles / grundfliesen / fonds / fondos / фоновая плитка						
40x120	rettificato	6	2,88	32,90	16	46,08 526,36 6
40x120	struttura 3D rett.	5	2,40	30,43	16	38,40 486,93 8
decori / decorative pieces / dekore / décors / decoraciones / декоры						
40x120	decoro Caleido	6	2,88	33,03	16	46,08 528,40 6
40x120	decoro Opera	4	1,92	12,90		
40x120	decoro Botanico	4	1,92	12,90		
40x40	mosaico	4	0,64	9,00	60	38,40 540,01 6
0,5x120	listello Metallo	8	0,05	2,20		

# Tactile

40x120



Gruppo Bili UNI EN 14411\_L

rivestimenti in pasta bianca - rettificato / white bodywall tiles - rectified / wandfliesen aus weissen ton scherben - rektifiziert / revetements en pate blanche - rectifié / revestimientos en pasta blanca - rectificado / облицовка из белой глины - ректифицируемый

superfici / surfaces / finitions / oberflächen / superficies / поверхности: semi-matt



RKMF Tactile Terra Struttura Resina 3D rettificato 40x120  
R17M Woodchoice Chevron Salt 11x54



SLIM  
6,0 mm

RKM9 Tactile Terra rettificato  
40x120

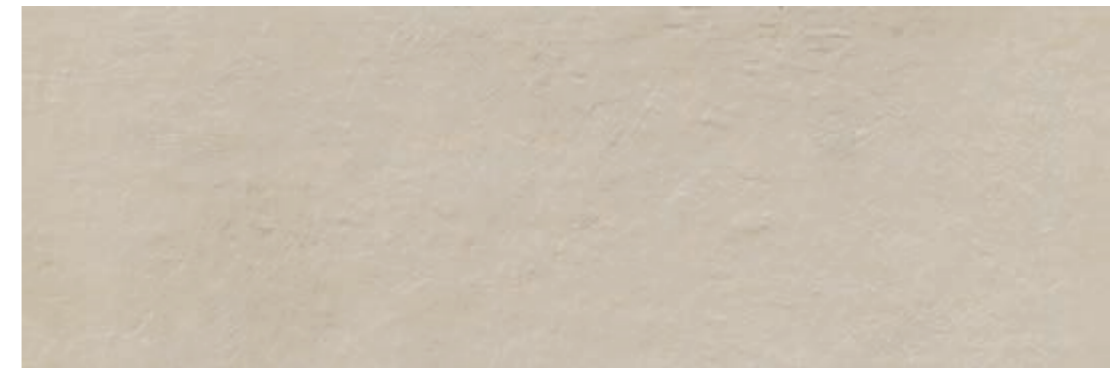

SLIM  
6,0 mm

RKM8 Tactile Ocra rettificato  
40x120

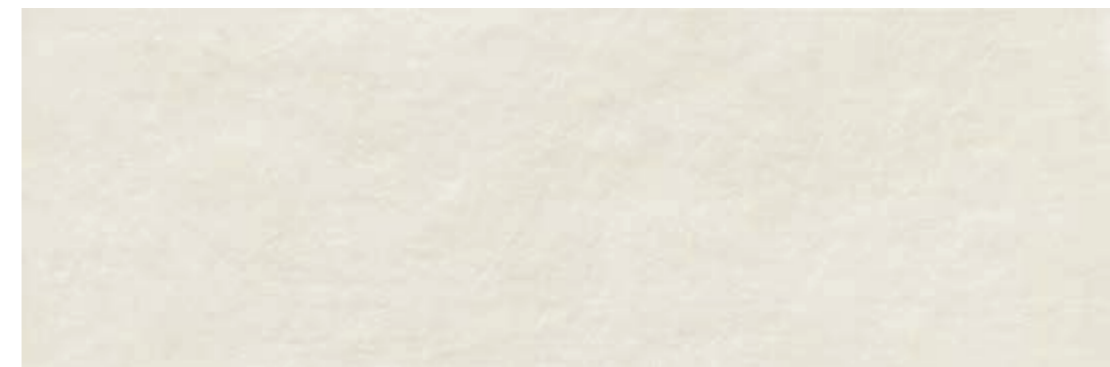

SLIM  
6,0 mm

RKM7 Tactile Titanio rettificato  
40x120

wall tiles

# Tactile

40x120

rivestimenti in pasta bianca - rettificato / white bodywall tiles - rectified / wandfliesen aus weissen ton scherben - rektifiziert / revetements en pate blanche - rectifié / revestimientos en pasta blanca - rectificado / облицовка из белой глины - ректифицируемый

superfici / surfaces / finitions / oberflächen / superficies / поверхности:  
**semi-matt**



SLIM  
6,0 mm

**RFJ** Tactile Carbone rettificato  
40x120



SLIM  
8,0 mm

**RKM** Tactile Terra Struttura Resina 3D rettificato  
40x120



SLIM  
6,0 mm

**RKM** Tactile Zinco rettificato  
40x120



SLIM  
8,0 mm

**RKM** Tactile Ocra Struttura Resina 3D rettificato  
40x120

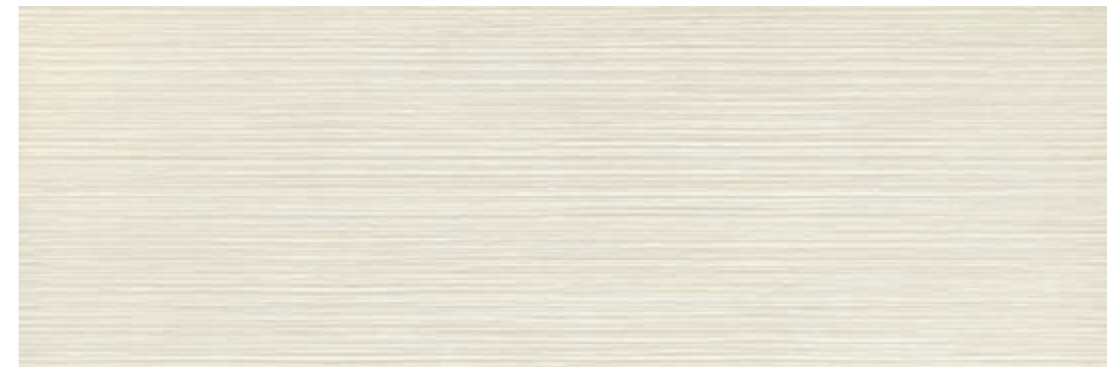

SLIM  
8,0 mm

**RKM** Tactile Titanio Struttura Resina 3D rettificato  
40x120

# Tactile

40x120

Gruppo BIII UNI EN 14411\_L

rivestimenti in pasta bianca - rettificato / white bodywall tiles - rectified / wandfliesen aus weissen ton scherben - rektifiziert / revetements en pate blanche - rectifié / revestimientos en pasta blanca - rectificado / облицовка из белой глины - ректифицируемый

superfici / surfaces / finitions / oberflächen / superficies / поверхности:  
**semi-matt**



SLIM  
8,0 mm

**RKMA** Tactile Carbone Struttura Resina 3D rettificato  
40x120

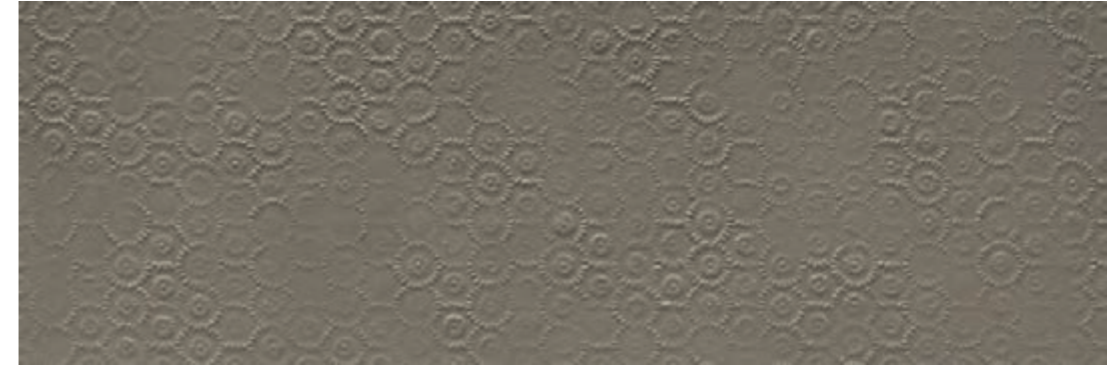

SLIM  
8,0 mm

**RKML** Tactile Terra Struttura Pizzo 3D rettificato  
40x120



SLIM  
8,0 mm

**RKMZ** Tactile Zinco Struttura Resina 3D rettificato  
40x120



SLIM  
8,0 mm

**RKMK** Tactile Ocra Struttura Pizzo 3D rettificato  
40x120



SLIM  
8,0 mm

**RKMJ** Tactile Titanio Struttura Pizzo 3D rettificato  
40x120

# Tactile

40x120

rivestimenti in pasta bianca - rettificato / white bodywall tiles - rectified / wandfliesen aus weissen ton scherben - rektifiziert / revetements en pate blanche - rectifié / revestimientos en pasta blanca - rettificado / облицовка из белой глины - ректифицируемый

superfici / surfaces / finitions / oberflächen / superficies / поверхности:  
semi-matt

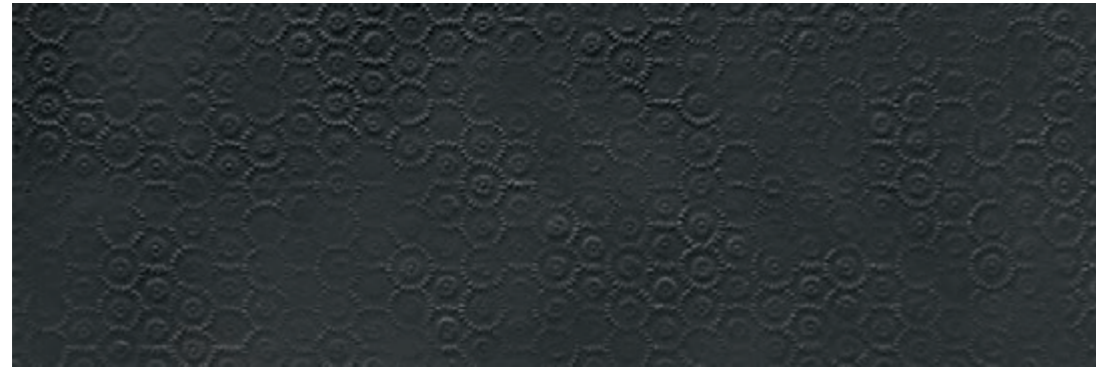

SLIM  
8,0 mm

RKMG Tactile Carbone Struttura Pizzo 3D rettificato  
40x120



SLIM  
8,0 mm

RKMH Tactile Zinco Struttura Pizzo 3D rettificato  
40x120



R6NA Tactile Decoro Memoria Ocra  
40x120

Abbinabile ai fondi / Matching with colours / Mit den Grundfliesen kombinierbar / Peut s'associer aux carreaux de base de couleurs / Puede combinarse con los fondos / Сочетается с фоновой плиткой:  
Titanio, Zinco, Carbone



R6N3 Tactile Decoro Memoria Titanio  
40x120

# Tactile

40x120

rivestimenti in pasta bianca - rettificato / white bodywall tiles - rectified / wandfliesen aus weissen ton scherben - rektifiziert / revêtements en pate blanche - rectifié / revestimientos en pasta blanca - rectificado / облицовка из белой глины - ректифицируемый

superfici / surfaces / finitions / oberflächen / superficies / поверхности:  
**semi-matt**

Abbinabile ai fondi / Matching with colours / Mit den Grundfliesen kombinierbar / Peut s'associer aux carreaux de base de couleurs / Puede combinarse con los fondos / Сочетается с фоновой плиткой:

Ocra, Terra

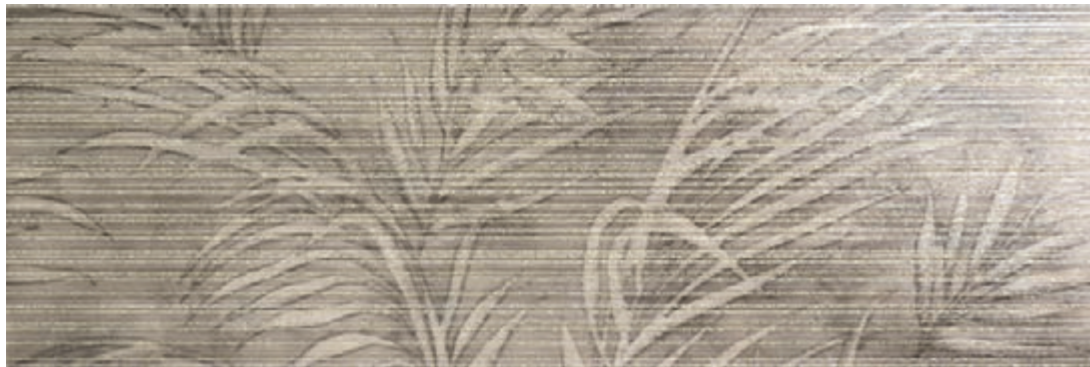
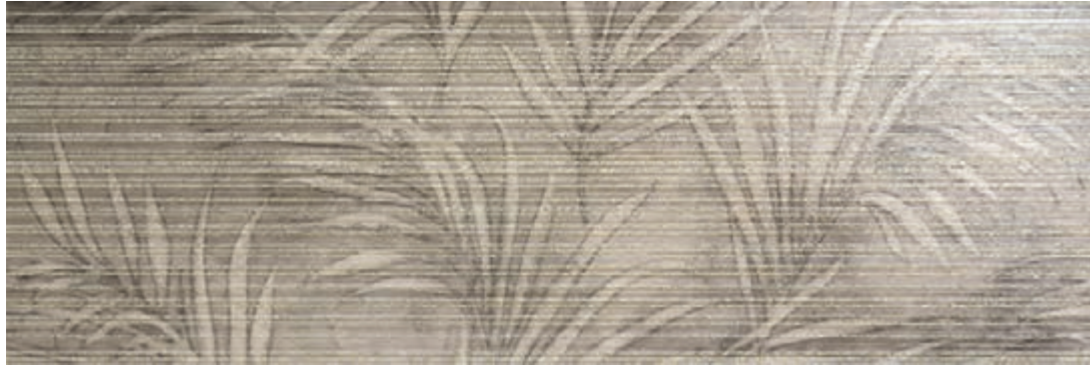

**R6LL** Tactile Decoro Garden Ocra\*  
80x120

Abbinabile ai fondi / Matching with colours / Mit den Grundfliesen kombinierbar / Peut s'associer aux carreaux de base de couleurs / Puede combinarse con los fondos / Сочетается с фоновой плиткой:

Titanio, Zinco, Carbone



**R6LM** Tactile Decoro Garden Titanio\*  
80x120



**RAV5** Tactile Decoro Shine Terra\*  
40x120



**RAV6** Tactile Decoro Shine Ocra\*  
40x120



**RAV7** Tactile Decoro Shine Titanio\*  
40x120



# Tactile

40x120

rivestimenti in pasta bianca - rettificato / white bodywall tiles - rectified / wandfliesen aus weissen ton scherben - rektifiziert / revetements en pate blanche - rectifié / revestimientos en pasta blanca - rectificado / облицовка из белой глины - ректифицируемый

superfici / surfaces / finitions / oberflächen / superficies / поверхности: semi-matt

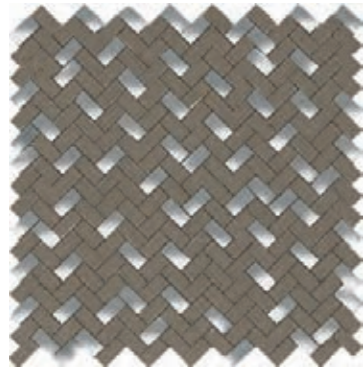

R71K Tactile Mosaico Bone Terra\*  
40x40



R71L Tactile Mosaico Bone Ocra\*  
40x40



R71M Tactile Mosaico Bone Titano\*  
40x40



R5TW Tactile Mosaico Deco Titano  
40x40

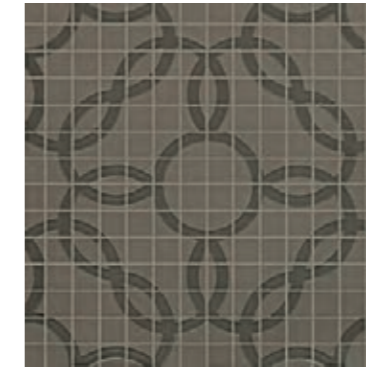

R5TV Tactile Mosaico Deco Terra  
40x40

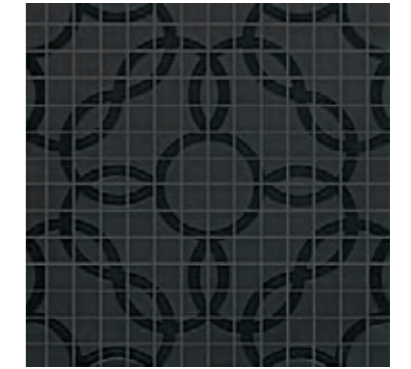

R5TX Tactile Mosaico Deco Carbone  
40x40

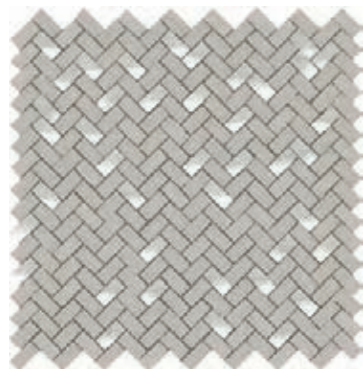

R71N Tactile Mosaico Bone Zinco\*  
40x40



R71Q Tactile Mosaico Bone Carbone\*  
40x40

## tech info



Mosaico assemblato su rete in fibra di vetro  
Mosaic mesh - mounted on fibreglass  
Auf Glasfasernetz geklebtes Mosaik  
Mosaïque montée sur filet en fibre de verre  
Mosaico enmallado sobre fibra de vidrio  
Мозаика, собранная на сетке из стекловолокна

### \*

Decoro con lustri/metalli preziosi utilizzabile a rivestimento; si consiglia la pulizia con detersivi neutri, non abrasivi. È sconsigliata la posa nell'area doccia. / Decors with lustres/precious metals used for covering; we recommend cleaning with neutral, non-abrasive detergents. Tiles should not be installed in the shower area. / Dekor mit Glanzelementen/Edelmetallen für die Wandverkleidung; es wird die Reinigung mit neutralen, scheuermittelfreien Reinigungsmitteln empfohlen. Die Verlegung in der Duschnische wird nicht empfohlen. / Décor avec lustres/métaux précieux à poser sur le mur. Lavage recommandé avec des détergents neutres, non abrasifs. Pose déconseillée dans la douche. / Decoración con elementos brillantes/metales preciosos utilizable para revestir superficies; se recomienda limpiarla con detergentes neutros, no abrasivos. Se desaconseja colocarla en el área de la ducha. / Декор с блестящим покрытием/драгоценными металлами, используемый для облицовки; рекомендуется чистка с использованием нейтральных, неабразивных моющих средств. Не рекомендуется укладка в душевой зоне.

## imballi / packaging / verpackungen / emballages / embalajes / упаковки

Scatole / Box / Karton / Boîte / Caja / Коробки Pallet / Pallet / Palette / Palette / Pallet / Поддон



### fondi / plain tiles / grundfliesen / fonds / fondos / фоновая плитка

40x120	6	2,88	32,90	16	46,08	526,36	6
40x120	5	2,40	30,43	16	38,40	486,93	8

### decori / decorative pieces / dekore / décors / decoraciones / декоры

40x120	decoro Memoria	6	2,88	33,03	16	46,08	528,40	6
40x120	decoro Shine	4	1,92	8,50				
80x120	decoro Garden	1	0,96	6,50				
40x40	mosaico Deco	4	0,64	8,50	60	38,40	510,00	6
40x40	mosaico Bone	4	0,64	9,00	60	38,40	540,01	6

# Terracrua

40x120



R65N Terracrua Sabbia rettificato 40x120  
R02M Terracrua Decoro Carpet Sabbia 40x120  
R53J Boom Sabbia 75x75

wall tiles

# Terracruda

40x120



**R5MW** Terracruda Luce rettificato  
40x120



**R70F** Terracruda Luce Struttura Arte 3D rettificato  
40x120



**R65N** Terracruda Sabbia rettificato  
40x120



**R6ZQ** Terracruda Sabbia Struttura Arte 3D rettificato  
40x120



**R6MR** Terracruda Calce rettificato  
40x120



**R657** Terracruda Calce Struttura Arte 3D rettificato  
40x120

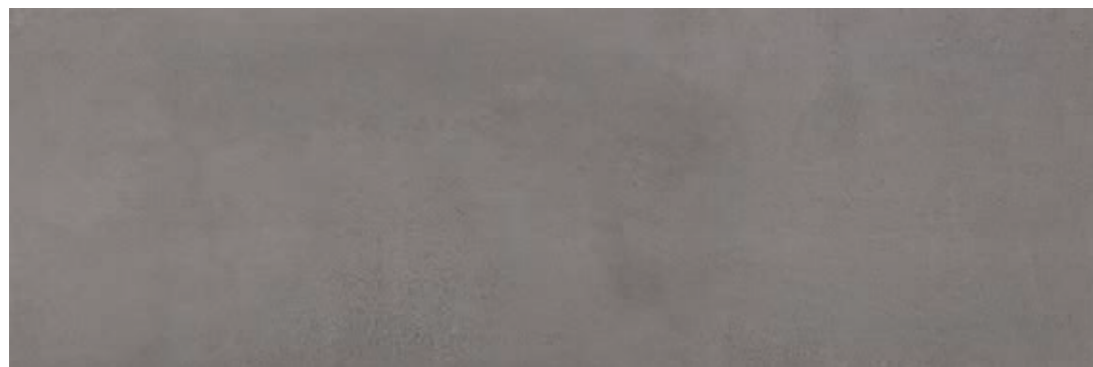

**R74J** Terracruda Piombo rettificato  
40x120



**R6UZ** Terracruda Piombo Struttura Arte 3D rettificato  
40x120

# Terracuda

40x120

rivestimenti in pasta bianca - rettificato / white bodywall tiles - rectified / wandfliesen aus weissen ton scherben - rektifiziert / revetements en pate blanche - rectifié / revestimientos en pasta blanca - rectificado / облицовка из белой глины - ректифицируемый

superfici / surfaces / finitions / oberflächen / superficies / поверхности:  
**matt**



SLIM  
8,0 mm

**R68M** Terracuda Luce Struttura Verso 3D rettificato  
40x120



SLIM  
8,0 mm

**R693** Terracuda Sabbia Struttura Verso 3D rettificato  
40x120



SLIM  
8,0 mm

**R6EF** Terracuda Calce Struttura Verso 3D rettificato  
40x120

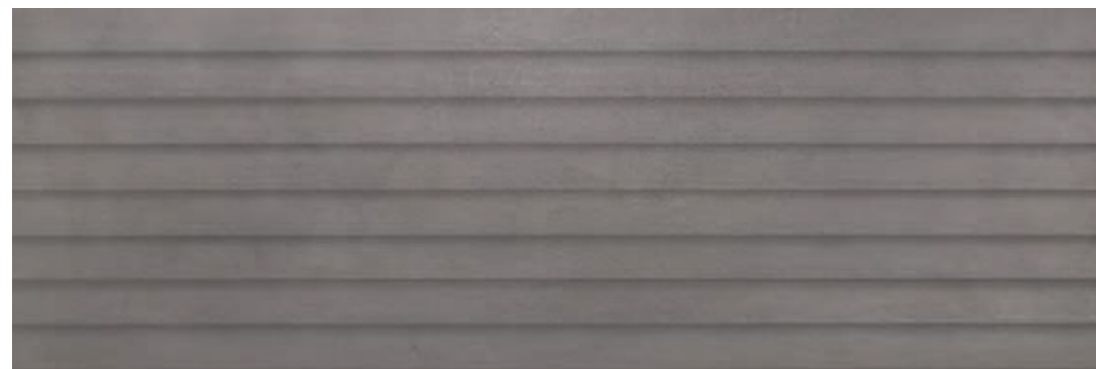

SLIM  
8,0 mm

**R6MK** Terracuda Piombo Struttura Verso 3D rettificato  
40x120



**R02N** Terracuda Decoro Carpet Luce  
40x120

Abbinabile ai fondi / Matching with colours / Mit den Grundfliesen kombinierbar / Peut s'associer aux carreaux de base de couleurs /  
Puede combinarse con los fondos / Сочетается с фоновой плиткой:  
Luce, Sabbia



**R02M** Terracuda Decoro Carpet Sabbia  
40x120

# Terracruda

40x120

rivestimenti in pasta bianca - rettificato / white bodywall tiles - rectified / wandfliesen aus weissen ton scherben - rektifiziert / revetements en pate blanche - rectifié / revestimientos en pasta blanca - rectificado / облицовка из белой глины - ректифицируемый

superfici / surfaces / finitions / oberflächen / superficies / поверхности:  
**matt**

Abbinabile ai fondi / Matching with colours / Mit den Grundfliesen kombinierbar / Peut s'associer aux carreaux de base de couleurs / Puede combinarse con los fondos / Сочетается с фоновой плиткой:

Luce, Sabbia



**R06A** Terracruda Mosaico Degradé Sabbia / Luce  
33,2x128,8

Abbinabile ai fondi / Matching with colours / Mit den Grundfliesen kombinierbar / Peut s'associer aux carreaux de base de couleurs / Puede combinarse con los fondos / Сочетается с фоновой плиткой:

Luce, Calce

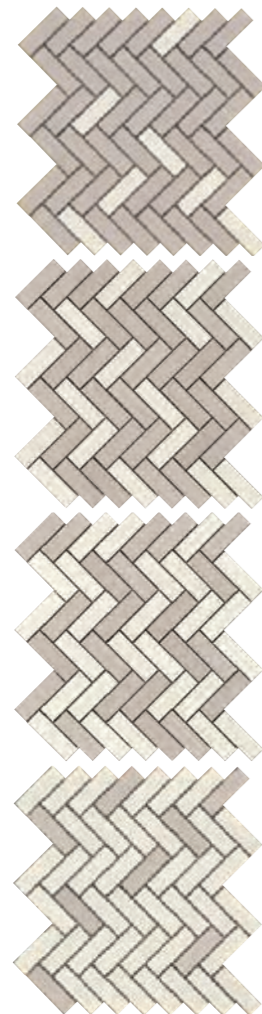

**R060** Terracruda Mosaico Degradé Calce / Luce  
33,2x128,8

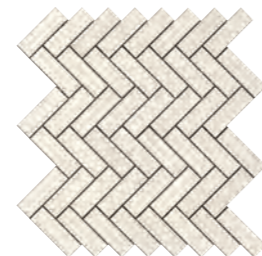

**R05Y** Terracruda Mosaico Luce  
33,2x33,2

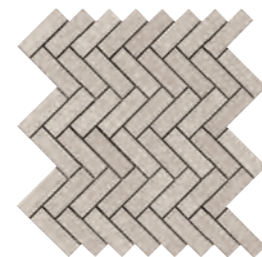

**R05X** Terracruda Mosaico Calce  
33,2x33,2

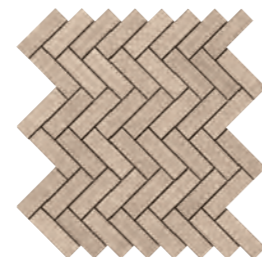

**R05Z** Terracruda Mosaico Sabbia  
33,2x33,2

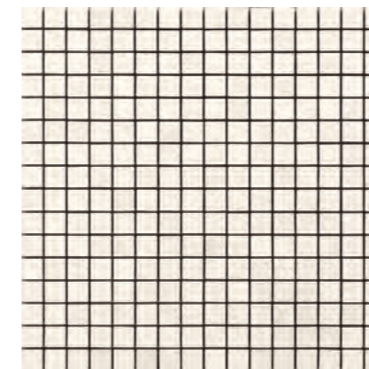

**R05K** Terracruda Mosaico Luce  
40x40

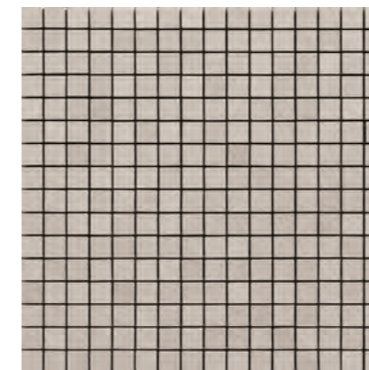

**R05J** Terracruda Mosaico Calce  
40x40

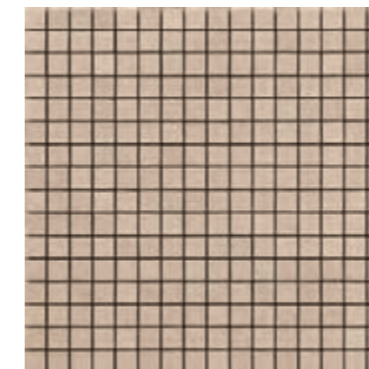

**R05L** Terracruda Mosaico Sabbia  
40x40

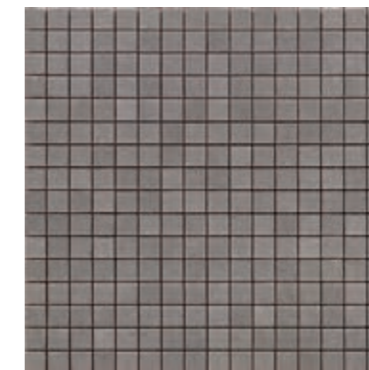

**R05H** Terracruda Mosaico Piombo  
40x40

Posa A / Laying pattern A / Verlegung A / Pose A / Colocación A / Укладка A

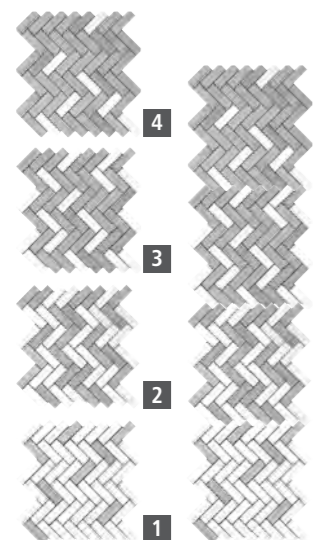

Posa B / Laying pattern B / Verlegung B / Pose B / Colocación B / Укладка B

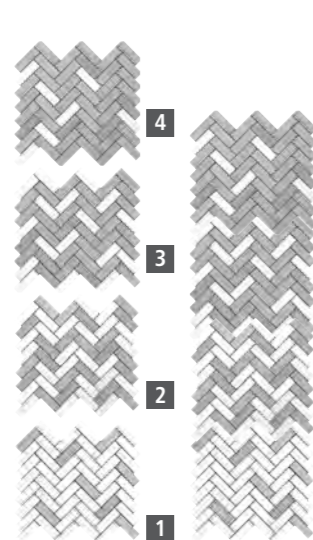

Per una corretta composizione del disegno seguire la numerazione progressiva. Oltre alla posa suggerita (Posa A), la composizione Degradé può essere realizzata ruotando i singoli elementi di 90 gradi (Posa B).

For the correct composition of the pattern, follow the numbered sequence. In addition to the suggested laying pattern (Laying pattern A), the Degradé composition can be created with the individual elements turned by 90 degrees (Laying pattern B).

Pour la bonne composition du dessin, suivre la numérotation séquentielle. Au-delà de la pose suggérée (Pose A), la composition Degradé peut être réalisée en faisant pivoter les éléments de 90 degrés (Pose B).

Für die richtige Zusammensetzung des Musters ist die laufende Nummerierung zu beachten. Neben der empfohlenen Verlegung (Verlegung A) kann Degradé auch unter 90-Grad-Drehung der einzelnen Elemente verlegt werden (Verlegung B).

Para configurar correctamente el dibujo, seguir la numeración progresiva. Además de la colocación sugerida (Colocación A), la composición Degradé se puede realizar rotando los varios elementos noventa grados (Colocación B).

Для правильного составления рисунка придерживаетесь возрастающей нумерации. Помимо рекомендуемой укладки (укладка A), композицию Degradé можно выполнить, поворачивая ее отдельные элементы на 90 градусов (укладка B).

## tech info



Mosaico assemblato su rete in fibra di vetro  
Mosaic mesh - mounted on fibreglass  
Auf Glasfasernetz geklebtes Mosaik  
Mosaïque montée sur filet en fibre de verre  
Mosaico enmallado sobre fibra de vidrio  
Мозаика, собранная на сетке из стекловолокна

## imballi / packaging / verpackungen / emballages / embalajes / упаковки

Scatole / Box / Karton / Boite / Caja / Коробки Pallet / Pallet / Palette / Palette / Pallet / Поддон



		M <sup>2</sup>	KG	M <sup>2</sup>	KG	≠ mm		
<b>fondi / plain tiles / grundfliesen / fonds / fondos / фоновая плитка</b>								
40x120		6	2,88	32,90	16	46,08	526,36	6
40x120	struttura Arte 3D	5	2,40	30,43	16	38,40	486,93	8
40x120	struttura Verso 3D	5	2,40	31,55	16	38,40	504,76	8
<b>decori / decorative pieces / dekore / décors / decoraciones / декоры</b>								
40x120	decoro	6	2,88	33,03	16	46,08	528,40	6
40x40	mosaico	4	0,64	5,54	36	23,04	199,40	6
33,2x33,2	mosaico liscia	4	0,44	2,08	108	47,62	224,08	6
33,2x128,8	mosaico degradé	1	0,43	1,94				

# Bistrot

40x120



Gruppo Bill UNI EN 14411\_L

rivestimenti in pasta bianca - rettificato / white bodywall tiles - rectified / wandfliesen aus weissen ton scherben - rektifiziert / revetements en pate blanche - rectifié / revestimientos en pasta blanca - rectificado / облицовка из белой глины - ректифицируемый

superfici / surfaces / finitions / oberflächen / superficies / поверхности:  
semi-matt



R4UF Bistrot Calacatta Michelangelo rettificato 40x120  
R4UM Bistrot Calacatta Michelangelo Struttura Dune 3D rettificato 40x120  
R4TP Woodtale Nocciola rettificato 20x120



R4UE Bistrot Pietrasanta rettificato  
40x120



R4UF Bistrot Calacatta Michelangelo rettificato  
40x120

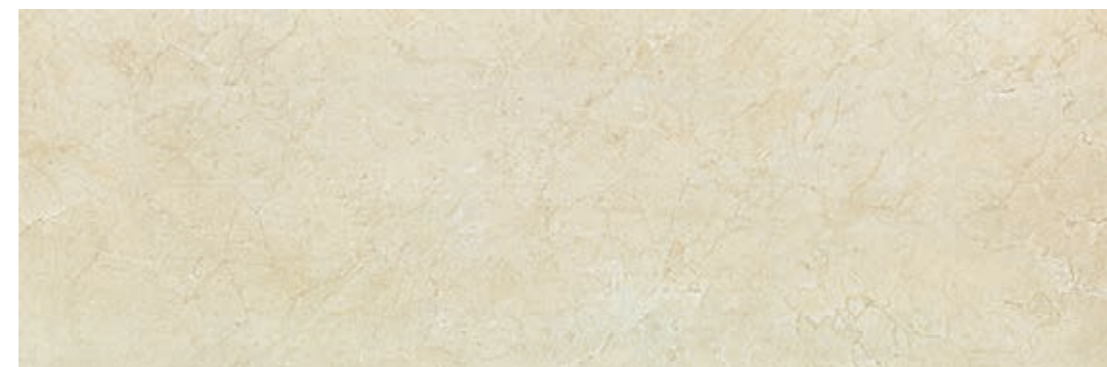

R4UG Bistrot Marfil rettificato  
40x120

wall tiles

# Bistrot

40x120

Gruppo Bili UNI EN 14411\_L

rivestimenti in pasta bianca - rettificato / white bodywall tiles - rectified / wandfliesen aus weissen ton scherben - rektifiziert / revetements en pate blanche - rectifié / revestimientos en pasta blanca - rectificado / облицовка из белой глины - ректифицируемый

superfici / surfaces / finitions / oberflächen / superficies / поверхности:  
**semi-matt**



SLIM  
8,0 mm

**R4UH** Bistrot Pietrasanta Struttura Natura 3D rettificato  
40x120

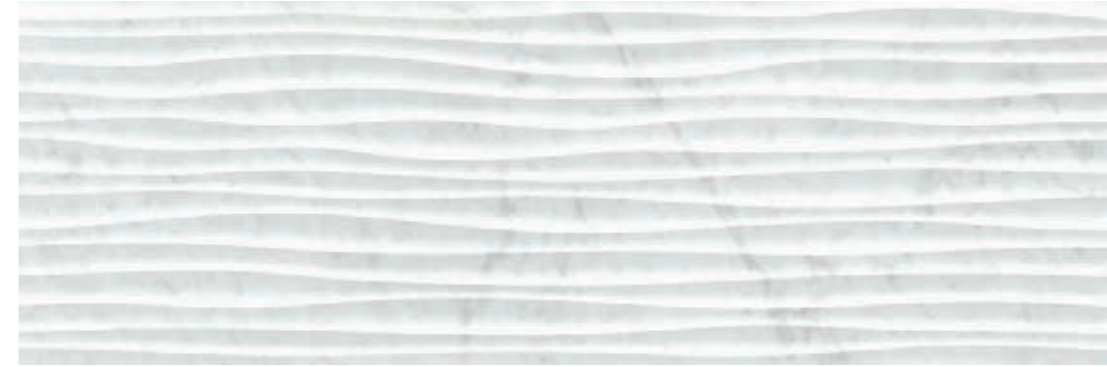

SLIM  
8,0 mm

**R4UL** Bistrot Pietrasanta Struttura Dune 3D rettificato  
40x120



SLIM  
8,0 mm

**R4UJ** Bistrot Calacatta Michelangelo Struttura Natura 3D rettificato  
40x120



SLIM  
8,0 mm

**R4UM** Bistrot Calacatta Michelangelo Struttura Dune 3D rettificato  
40x120



SLIM  
8,0 mm

**R4UK** Bistrot Marfil Struttura Natura 3D rettificato  
40x120



SLIM  
8,0 mm

**R4UN** Bistrot Marfil Struttura Dune 3D rettificato  
40x120

# Bistrot

40x120

rivestimenti in pasta bianca - rettificato / white bodywall tiles - rectified / wandfliesen aus weissen ton scherben - rektifiziert / revetements en pate blanche - rectifié / revestimientos en pasta blanca - rectificado / облицовка из белой глины - ректифицируемый

superfici / surfaces / finitions / oberflächen / superficies / поверхности:  
semi-matt



**R503** Bistrot Decoro Pietrasanta\* / \*\*  
40x120



**R504** Bistrot Decoro Calacatta Michelangelo\* / \*\*  
40x120



**R505** Bistrot Decoro Marfil\* / \*\*  
40x120

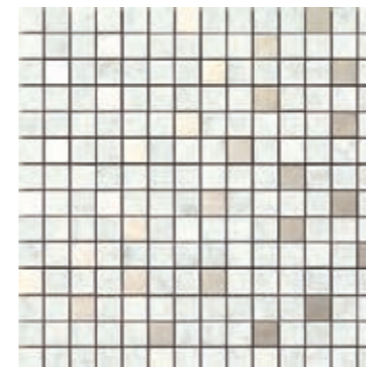

**R42T** Bistrot Mosaico Pietrasanta\*\*  
40x40

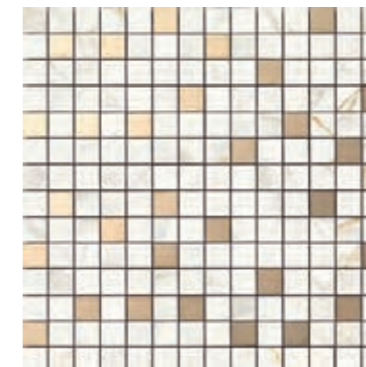

**R42U** Bistrot Mosaico Calacatta Michelangelo\*\*  
40x40

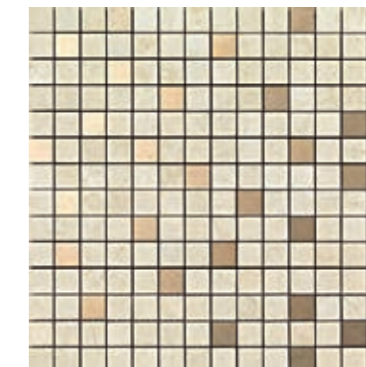

**R42V** Bistrot Mosaico Marfil\*\*  
40x40

## tech info



Mosaico assemblato su rete in fibra di vetro  
Mosaic mesh - mounted on fibreglass  
Auf Glasfasernetz geklebtes Mosaik  
Mosaïque montée sur filet en fibre de verre  
Mosaico enmallado sobre fibra de vidrio  
Мозаика, собранная на сетке из стекловолокна

### \*

Si consiglia di mantenere il senso di posa indicato  
Compliance with the specified laying direction is strongly recommended  
Es wird empfohlen, die angegebene Verlegerichtung zu beachten  
Il est recommandé de conserver le sens de pose indiqué  
Se aconseja mantener el sentido de colocación indicado  
Рекомендуется сохранить указанное направление укладки

### \*\*

Decoro con lustri/metalli preziosi utilizzabile a rivestimento; si consiglia la pulizia con detersivi neutri, non abrasivi. È sconsigliata la posa nell'area doccia. / Decors with lustres/precious metals used for covering; we recommend cleaning with neutral, non-abrasive detergents. Tiles should not be installed in the shower area. / Dekor mit Glanzelementen/Edelmetallen für die Wandverkleidung; es wird die Reinigung mit neutralen, scheuermittelfreien Reinigungsmitteln empfohlen. Die Verlegung in der Duschnische wird nicht empfohlen. / Décor avec lustres/métaux précieux à poser sur le mur. Lavage recommandé avec des détergents neutres, non abrasifs. Pose déconseillée dans la douche. / Decoración con elementos brillantes/metales preciosos utilizable para revestir superficies; se recomienda limpiarla con detergentes neutros, no abrasivos. Se desaconseja colocarla en el área de la ducha. / Декор с блестящим покрытием/драгоценными металлами, используемый для облицовки; рекомендуется чистка с использованием нейтральных, неабразивных моющих средств. Не рекомендуется укладка в душевой зоне.

## imballi / packaging / verpackungen / emballages / embalajes / упаковки

Scatole / Box / Karton / Boite / Caja / Коробки Pallet / Pallet / Palette / Palette / Pallet / Поддон

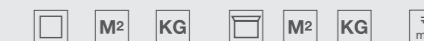

### fondi / plain tiles / grundfliesen / fonds / fondos / фоновая плитка

Size	Structure	Boxes	Weight (KG)	Pallets	Weight (KG)	Thickness (mm)
40x120		6	2,88	16	46,08	6
40x120	struttura Natura 3D	5	2,40	16	38,40	8
40x120	struttura Dune 3D	5	2,40	16	38,40	8

### decori / decorative pieces / dekore / décors / decoraciones / декоры

Size	Decor	Boxes	Weight (KG)	Pallets	Weight (KG)	Thickness (mm)
40x120	decoro	4	1,92	19,70		
40x40	mosaico	4	0,64	8,16	60	38,40
					489,80	6



# Ritual

32,5x97,7



Gruppo Bili UNI EN 14411\_L  
rivestimenti in pasta bianca - rettificato / white body wall tiles - rectified / wandfliesen aus weissen ton scherben - rektifiziert / revêtements en pate blanche - rectifié /  
revestimientos en pasta blanca - rectificado / облицовка из белой глины - ректифицируемый

superfici / surfaces / finitions / oberflächen / superficies / поверхности:  
**mat**



R6ND Ritual Bianco rettificato 32,5x97,7  
R5QK Ritual Decoro Vanity Bianco rettificato 32,5x97,7  
R5SD Woodreal Tortora 10x100 / 13x100



R6ND Ritual Bianco rettificato  
32,5x97,7



R6NC Ritual Grigio rettificato  
32,5x97,7

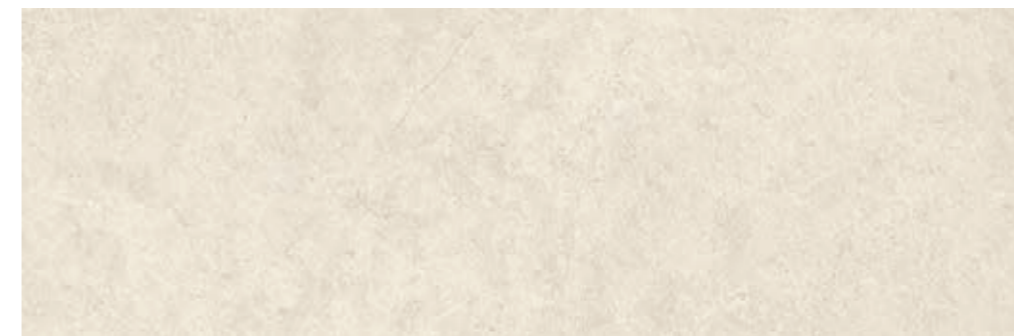

R6NE Ritual Avorio rettificato  
32,5x97,7

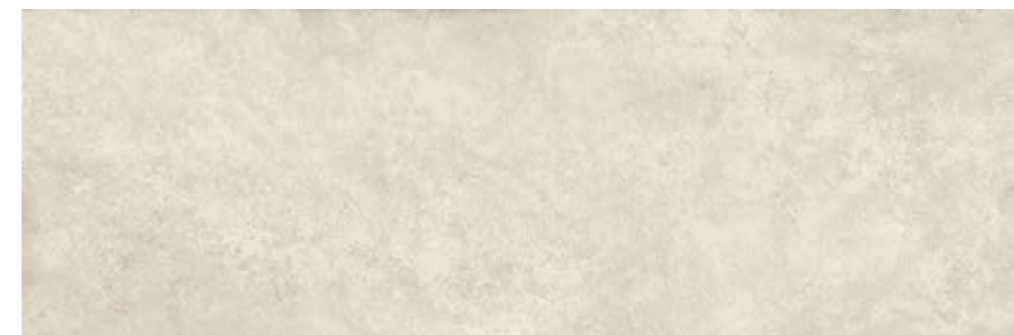

R6NF Ritual Greige rettificato  
32,5x97,7

wall tiles

# Ritual

32,5x97,7

rivestimenti in pasta bianca - rettificato / white body wall tiles - rectified / wandfliesen aus weissen ton scherben - rektifiziert / revetements en pate blanche - rectifié / revestimientos en pasta blanca - rettificado / облицовка из белой глины - ректифицируемый

superfici / surfaces / finitions / oberflächen / superficies / поверхности:  
**matt**



SLIM  
8,0 mm

**R6NH** Ritual Bianco Struttura Microcut 3D rettificato  
32,5x97,7



SLIM  
8,0 mm

**R6NM** Ritual Bianco Struttura Domino 3D rettificato  
32,5x97,7



SLIM  
8,0 mm

**R6NG** Ritual Grigio Struttura Microcut 3D rettificato  
32,5x97,7



SLIM  
8,0 mm

**R6NL** Ritual Grigio Struttura Domino 3D rettificato  
32,5x97,7



SLIM  
8,0 mm

**R6NJ** Ritual Avorio Struttura Microcut 3D rettificato  
32,5x97,7



SLIM  
8,0 mm

**R6NN** Ritual Avorio Struttura Domino 3D rettificato  
32,5x97,7



SLIM  
8,0 mm

**R6NK** Ritual Greige Struttura Microcut 3D rettificato  
32,5x97,7



SLIM  
8,0 mm

**R6NP** Ritual Greige Struttura Domino 3D rettificato  
32,5x97,7

# Ritual

32,5x97,7

rivestimenti in pasta bianca - rettificato / white body wall tiles - rectified / wandfliesen aus weissen ton scherben - rektifiziert / revêtements en pate blanche - rectifié / revestimientos en pasta blanca - retificado / облицовка из белой глины - ректифицируемый

superfici / surfaces / finitions / oberflächen / superficies / поверхности:  
**matt**



**R6NR** Ritual Decoro Cross Bianco  
32,5x97,7

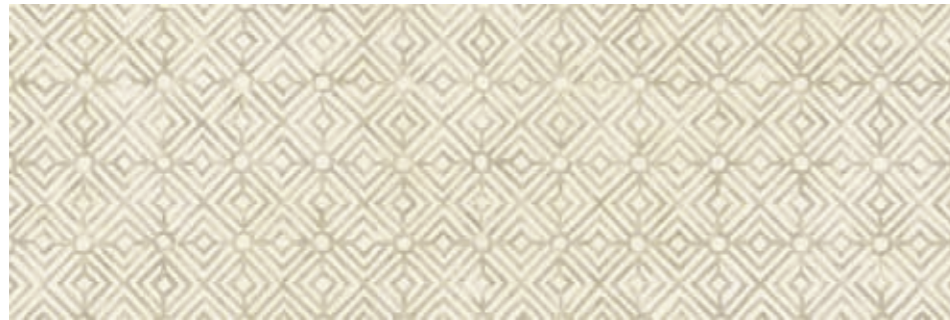

**R6NS** Ritual Decoro Cross Avorio  
32,5x97,7



**R724** Ritual Decoro Jaquard Bianco\*  
32,5x97,7



**R725** Ritual Decoro Jaquard Avorio\*  
32,5x97,7

Abbinabile ai fondi / Matching with colours / Mit den Grundfliesen kombinierbar / Peut s'associer aux carreaux de base de couleurs / Puede combinarse con los fondos / Сочетается с фоновой плиткой:

Avorio, Greige



**R5QL** Ritual Decoro Vanity Avorio\*  
32,5x97,7

SLIM  
8,0 mm

Abbinabile ai fondi / Matching with colours / Mit den Grundfliesen kombinierbar / Peut s'associer aux carreaux de base de couleurs / Puede combinarse con los fondos / Сочетается с фоновой плиткой:

Bianco, Grigio



**R5QK** Ritual Decoro Vanity Bianco\*  
32,5x97,7

SLIM  
8,0 mm

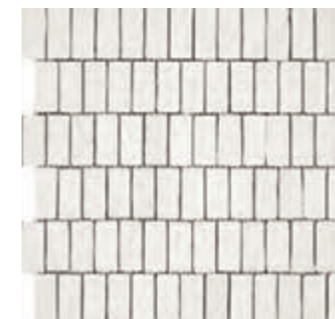

**R18C** Ritual Mosaico Bianco  
32,5x32,5

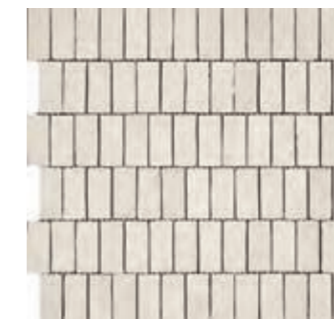

**R18A** Ritual Mosaico Grigio  
32,5x32,5

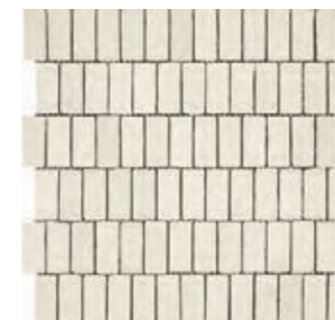

**R18D** Ritual Mosaico Avorio  
32,5x32,5

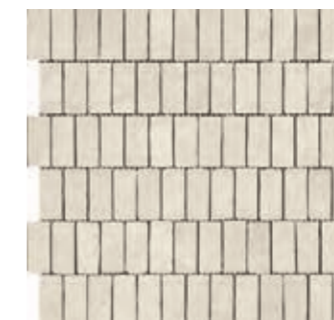

**R18E** Ritual Mosaico Greige  
32,5x32,5

# Ritual

32,5x97,7



SLIM  
8,0 mm

R5QJ Ritual Decoro Bouquet Avorio\*  
130x97,7



SLIM  
8,0 mm

R5QH Ritual Decoro Bouquet Bianco\*  
130x97,7

### tech info



Mosaico assemblato su rete in fibra di vetro / Mosaic mesh - mounted on fibreglass / Auf Glasfasernetz geklebtes Mosaik / Mosaïque montée sur filet en fibre de verre / Mosaico enmallado sobre fibra de vidrio / Мозаика, собранная на сетке из стекловолокна

\*

Decoro con lustr/metalli preziosi utilizzabile a rivestimento; si consiglia la pulizia con detersivi neutri, non abrasivi. È sconsigliata la posa nell'area doccia. / Decors with lustres/precious metals used for covering; we recommend cleaning with neutral, non-abrasive detergents. Tiles should not be installed in the shower area. / Dekor mit Glanzelementen/Edelmetallen für die Wandverkleidung; es wird die Reinigung mit neutralen, scheuermittelfreien Reinigungsmitteln empfohlen. Die Verlegung in der Duschnische wird nicht empfohlen. / Décor avec lustres/métaux précieux à poser sur le mur. Lavage recommandé avec des détergents neutres, non abrasifs. Pose déconseillée dans la douche. / Decoración con elementos brillantes/metales preciosos utilizable para revestir superficies; se recomienda limpiarla con detergentes neutros, no abrasivos. Se desaconseja colocarla en el área de la ducha. / Декор с блестящим покрытием/драгоценными металлами, используемый для облицовки; рекомендуется чистка с использованием нейтральных, неабразивных моющих средств. Не рекомендуется укладка в душевой зоне.

### imballi / packaging / verpackungen / emballages / embalajes / упаковки

Scatole / Box / Karton / Boîte / Caja / Коробки

Pallet / Pallet / Palette / Palette / Pallet / Поддон

	M <sup>2</sup>	KG		M <sup>2</sup>	KG	≠ mm
--	----------------	----	--	----------------	----	------

### fondi / plain tiles / grundfliesen / fonds / fondos / фоновая плитка

32,5x97,7	6	1,91	21,00	16	30,48	336,29	6
32,5x97,7 struttura microcut 3D	5	1,59	19,72	16	25,40	315,00	8
32,5x97,7 struttura domino 3D	5	1,59	19,72	16	25,40	315,00	8

### decori / decorative pieces / dekore / décors / decoraciones / декоры

32,5x97,7 decoro Cross	6	1,91	21,00	16	30,48	336,29	6
32,5x97,7 decoro Jaquard	4	1,27	17,70				
32,5x97,7 decoro Vanity	4	1,27	18,00				
130x97,7 decoro Bouquet	1	1,27	18,00				
32,5x32,5 mosaico	4	0,42	11,86				

# TexCem

32,5x97,7



rivestimenti in pasta bianca - rettificato / white bodywall tiles - rectified / wandfliesen aus weissen ton scherben - rektifiziert / revêtements en pate blanche - rectifié / revestimientos en pasta blanca - rectificado / облицовка из белой глины - ректифицируемый

superfici / surfaces / finitions / oberflächen / superficies / поверхности:  
**matt**



R5NW TexCem Bianco Struttura Tria 3D rettificato 40x120  
R5NL TexCem Bianco rettificato 40x120  
R61J Re\_Solution Linen rettificato 75x75



SLIM  
6,0 mm

R5NL TexCem Bianco rettificato  
32,5x97,7

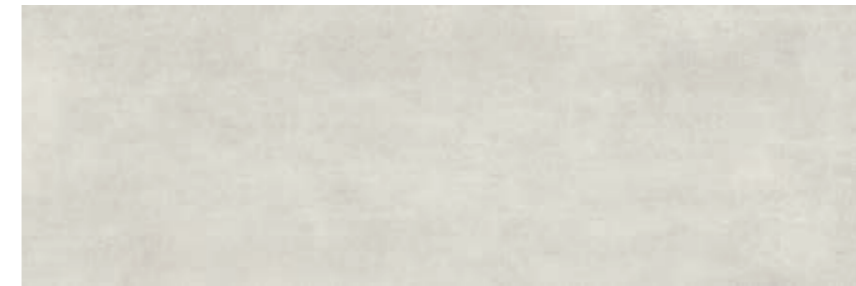

SLIM  
6,0 mm

R5NK TexCem Grigio rettificato  
32,5x97,7

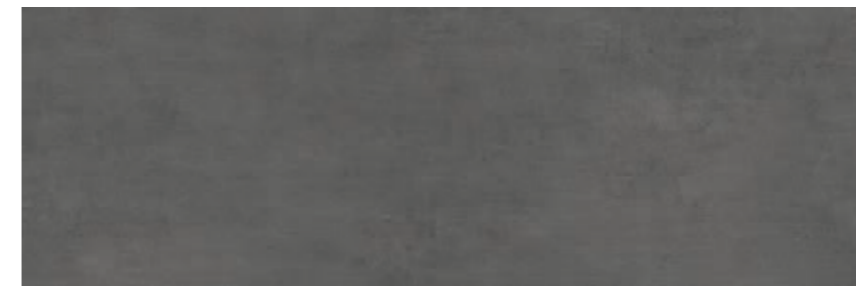

SLIM  
6,0 mm

R5NJ TexCem Ottanio rettificato  
32,5x97,7



SLIM  
6,0 mm

R5NG TexCem Avorio rettificato  
32,5x97,7



SLIM  
6,0 mm

R5NH TexCem Cotto rettificato  
32,5x97,7

wall tiles



SLIM  
8,0 mm

**R5NR** TexCem Bianco Struttura Groove 3D rettificato  
32,5x97,7



SLIM  
8,0 mm

**R5NQ** TexCem Grigio Struttura Groove 3D rettificato  
32,5x97,7

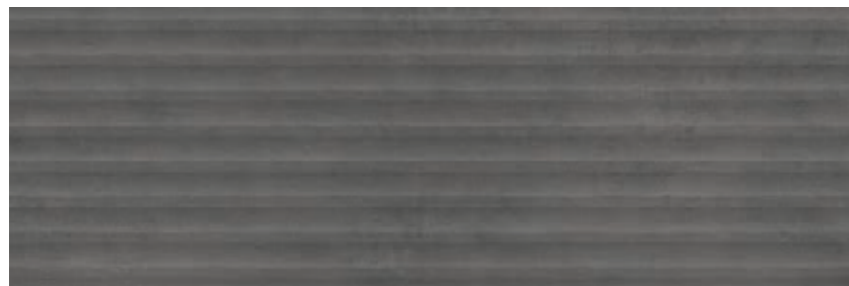

SLIM  
8,0 mm

**R5NP** TexCem Ottanio Struttura Groove 3D rettificato  
32,5x97,7

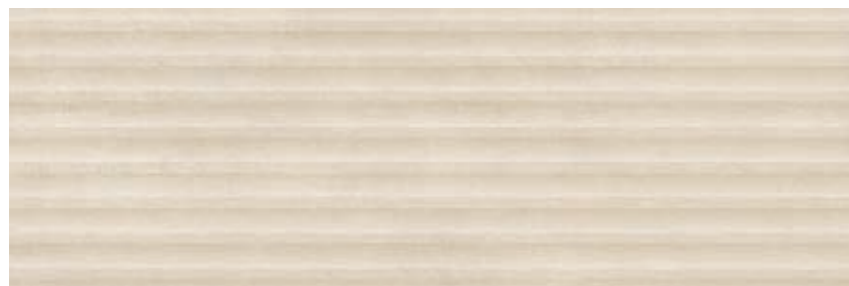

SLIM  
8,0 mm

**R5NM** TexCem Avorio Struttura Groove 3D rettificato  
32,5x97,7

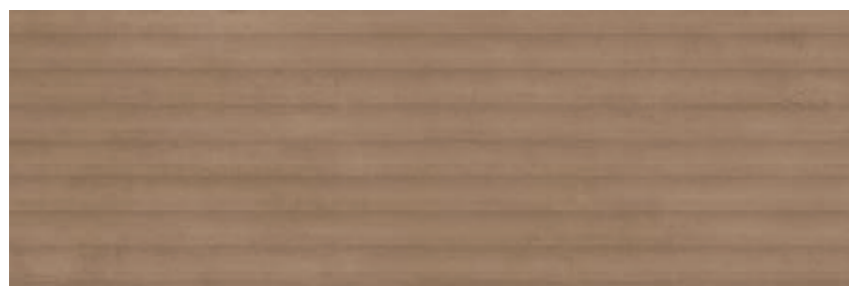

SLIM  
8,0 mm

**R5NN** TexCem Cotto Struttura Groove 3D rettificato  
32,5x97,7



SLIM  
8,0 mm

**R5NW** TexCem Bianco Struttura Tria 3D rettificato  
32,5x97,7

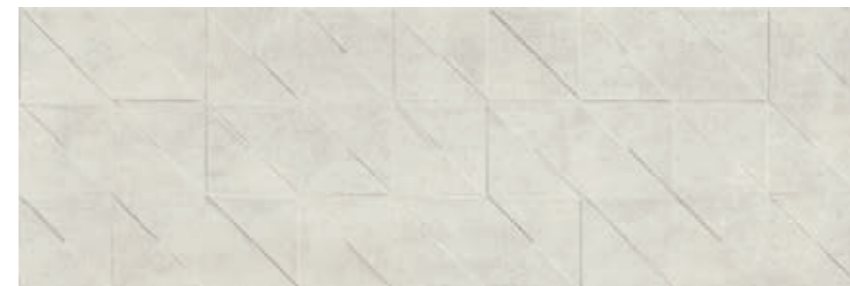

SLIM  
8,0 mm

**R5NV** TexCem Grigio Struttura Tria 3D rettificato  
32,5x97,7

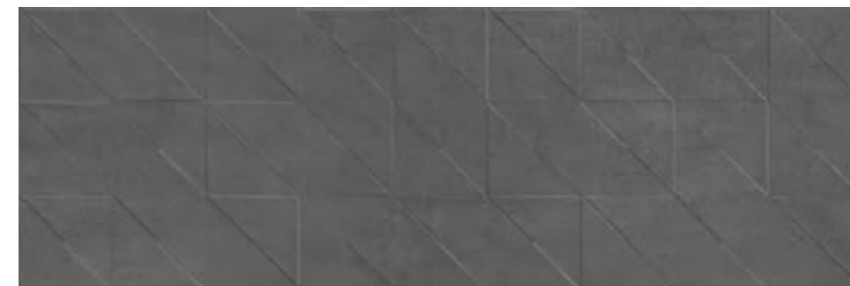

SLIM  
8,0 mm

**R5NU** TexCem Ottanio Struttura Tria 3D rettificato  
32,5x97,7



SLIM  
8,0 mm

**R5NS** TexCem Avorio Struttura Tria 3D rettificato  
32,5x97,7



SLIM  
8,0 mm

**R5NT** TexCem Cotto Struttura Tria 3D rettificato  
32,5x97,7

# TexCem

32,5x97,7

**rivestimenti in pasta bianca - rettificato** / white bodywall tiles - rectified / wandfliesen aus weissen ton scherben - rektifiziert / revetements en pate blanche - rectifié / revestimientos en pasta blanca - rectificado / облицовка из белой глины - ректифицируемый

**superfici** / surfaces / finitions / oberflächen / superficies / поверхности:  
**matt**

Abbinabile ai fondi / Matching with colours / Mit den Grundfliesen kombinierbar / Peut s'associer aux carreaux de base de couleurs / Puede combinarse con los fondos / Сочетается с фоновой плиткой:

Bianco, Grigio, Ottanio



**R5NY** TexCem Decoro Patch Bianco  
32,5x97,7

Abbinabile ai fondi / Matching with colours / Mit den Grundfliesen kombinierbar / Peut s'associer aux carreaux de base de couleurs / Puede combinarse con los fondos / Сочетается с фоновой плиткой:

Bianco, Grigio, Ottanio



**R5PA** TexCem Decoro Esagone Bianco  
32,5x97,7

Abbinabile ai fondi / Matching with colours / Mit den Grundfliesen kombinierbar / Peut s'associer aux carreaux de base de couleurs / Puede combinarse con los fondos / Сочетается с фоновой плиткой:

Avorio, Cotto



**R5NX** TexCem Decoro Patch Avorio  
32,5x97,7

Abbinabile ai fondi / Matching with colours / Mit den Grundfliesen kombinierbar / Peut s'associer aux carreaux de base de couleurs / Puede combinarse con los fondos / Сочетается с фоновой плиткой:

Avorio, Cotto



**R5NZ** TexCem Decoro Esagone Avorio  
32,5x97,7

Abbinabile ai fondi / Matching with colours / Mit den Grundfliesen kombinierbar / Peut s'associer aux carreaux de base de couleurs / Puede combinarse con los fondos / Сочетается с фоновой плиткой:

Bianco, Grigio, Ottanio

Avorio, Cotto



**R6QU** TexCem Decoro Magnolia Bianco  
130x97,7



**R6QT** TexCem Decoro Magnolia Avorio  
130x97,7

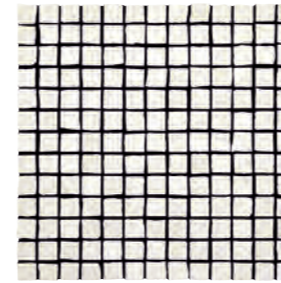

**R6TH** TexCem Mosaico Bianco  
32,5x32,5

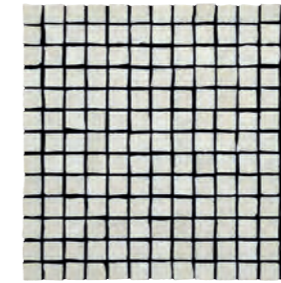

**R6TG** TexCem Mosaico Grigio  
32,5x32,5

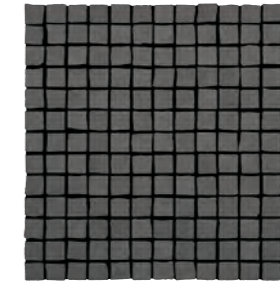

**R6TF** TexCem Mosaico Ottanio  
32,5x32,5

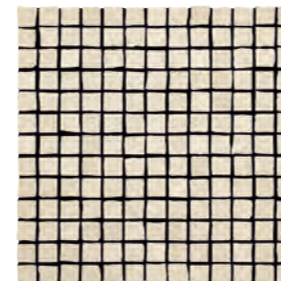

**R6TD** TexCem Mosaico Avorio  
32,5x32,5

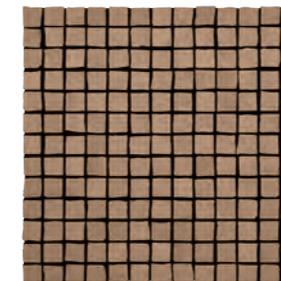

**R6TE** TexCem Mosaico Cotto  
32,5x32,5

### tech info



Mosaico assemblato su rete in fibra di vetro  
Mosaic mesh - mounted on fibreglass  
Auf Glasfasernetz geklebtes Mosaik  
Mosaïque montée sur filet en fibre de verre  
Mosaico enmallado sobre fibra de vidrio  
Мозаика, собранная на сетке из стекловолокна

### imballi / packaging / verpackungen / emballages / embalajes / упаковки

Scatole / Box / Karton / Boite / Caja / Коробки Pallet / Pallet / Palette / Palette / Pallet / Поддон



fondi / plain tiles / grundfliesen / fonds / fondos / фоновая плитка						
32,5x97,7 rettificato	6	1,91	21,00	16	30,48	336,29
32,5x97,7 struttura 3D rett.	5	1,59	21,00	16	25,40	336,01
<b>decori / decorative pieces / dekore / décors / decoraciones / декоры</b>						
32,5x97,7 dec. Patch / Esagone	6	1,91	21,00	16	30,48	336,29
130x97,7 decoro Magnolia	1	1,27	4,25			
32,5x32,5 mosaico	4	0,42	12,50	48	20,28	596,00



# Imperiale

30x90



R74K Imperiale Crema rettificato 30x90  
R759 Imperiale Crema Struttura Gemma 3D rettificato 30x90  
R75Y Imperiale Listello Titanio 1x90  
R734 Imperiale Crema Glossy rettificato 58x58

# Imperiale

30x90

Gruppo BIII UNI EN 14411\_L

rivestimenti in pasta bianca / white bodywall tiles / wandfliesen aus weissen ton scherben / revetements en pate blanche / revestimientos en pasta blanca / облицовка из белой глины

superfici / surfaces / finitions / oberflächen / superficies / поверхности:  
**glossy**



**R74D** Imperiale Bianco rettificato  
30x90



**R75K** Imperiale Mosaico Bianco  
30x30



**R74G** Imperiale Avorio rettificato  
30x90



**R75N** Imperiale Mosaico Avorio  
30x30

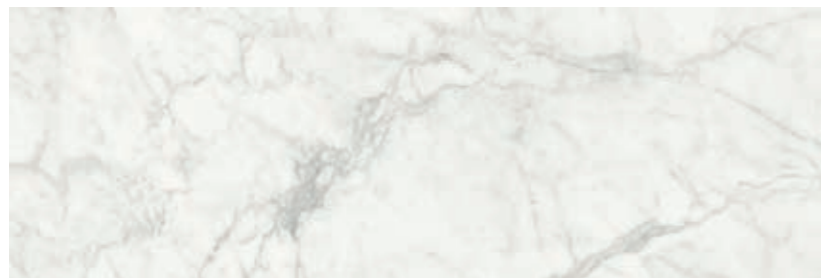

**R74E** Imperiale Statuarietto rettificato  
30x90



**R75L** Imperiale Mosaico Statuarietto  
30x30



**R74H** Imperiale Travertino rettificato  
30x90

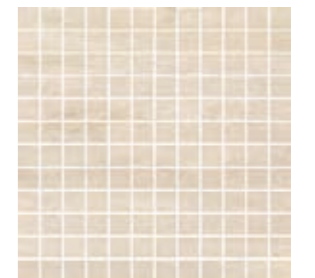

**R75P** Imperiale Mosaico Travertino  
30x30

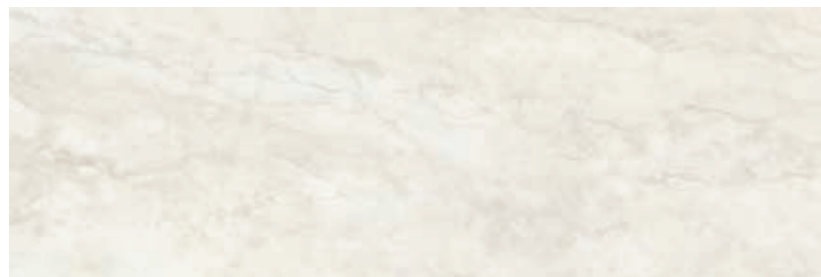

**R74F** Imperiale Calacatta rettificato  
30x90

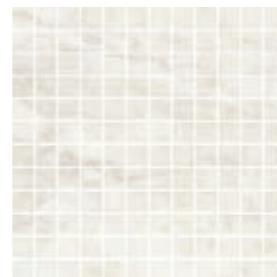

**R75M** Imperiale Mosaico Calacatta  
30x30



**R74K** Imperiale Crema rettificato  
30x90

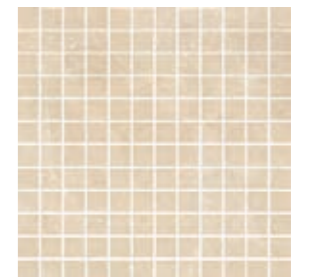

**R75Q** Imperiale Mosaico Crema  
30x30

# Imperiale

30x90



**R755** Imperiale Bianco Struttura Gemma 3D rettificato  
30x90



**R759** Imperiale Avorio Struttura Gemma 3D rettificato  
30x90



**R757** Imperiale Statuarietto Struttura Gemma 3D rettificato  
30x90

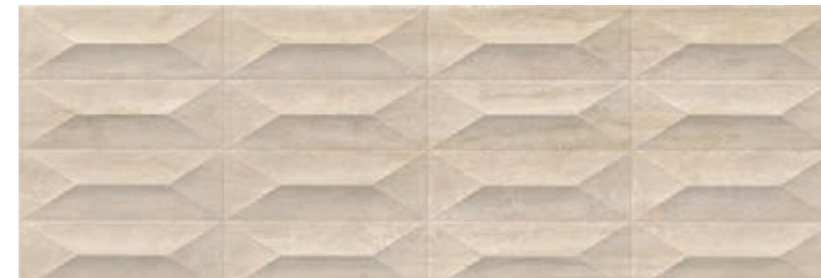

**R75A** Imperiale Travertino Struttura Gemma 3D rettificato  
30x90

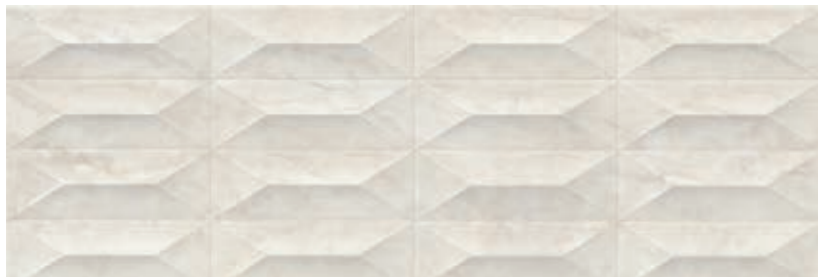

**R758** Imperiale Calacatta Struttura Gemma 3D rettificato  
30x90



**R75C** Imperiale Crema Struttura Gemma 3D rettificato  
30x90

# Imperiale

30x90



**R74M** Imperiale Bianco Struttura Shanghai 3D rettificato  
30x90



**R74Q** Imperiale Avorio Struttura Shanghai 3D rettificato  
30x90

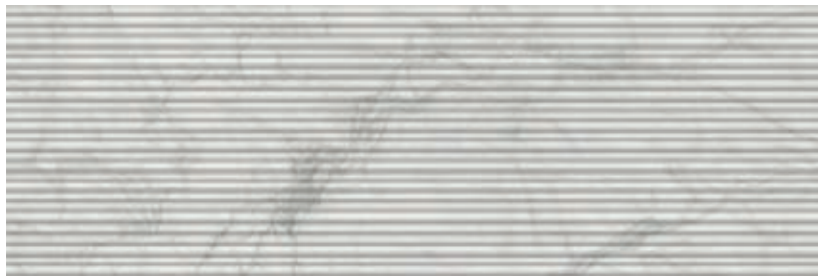

**R74N** Imperiale Statuarietto Struttura Shanghai 3D rettificato  
30x90



**R74R** Imperiale Travertino Struttura Shanghai 3D rettificato  
30x90



**R74P** Imperiale Calacatta Struttura Shanghai 3D rettificato  
30x90



**R74S** Imperiale Crema Struttura Shanghai 3D rettificato  
30x90

# Imperiale

30x90



R75T Imperiale Decoro Merletto Bianco  
30x90



R75U Imperiale Decoro Merletto Statuarietto  
30x90



R75V Imperiale Decoro Merletto Calacatta  
30x90



R75W Imperiale Decoro Merletto Crema  
30x90

Abbinabile ai fondi / Matching with colours / Mit den Grundfliesen kombinierbar / Peut s'associer aux carreaux de base de couleurs / Puede combinarse con los fondos / Сочетается с фоновой плиткой:

Bianco, Statuarietto



R75E Imperiale Decoro Tangram Bianco  
30x90

Abbinabile ai fondi / Matching with colours / Mit den Grundfliesen kombinierbar / Peut s'associer aux carreaux de base de couleurs / Puede combinarse con los fondos / Сочетается с фоновой плиткой:

Travertino, Crema



R75G Imperiale Decoro Tangram Travertino  
30x90

R75Y Imperiale Listello Titanio  
1x90

## tech info



Mosaico assemblato su rete in fibra di vetro  
Mosaic mesh - mounted on fibreglass  
Auf Glasfasernetz geklebtes Mosaik  
Mosaïque montée sur filet en fibre de verre  
Mosaico enmallado sobre fibra de vidrio  
Мозаика, собранная на сетке из стекловолокна

## imballi / packaging / verpackungen / emballages / embalajes / упаковки

Scatole / Box / Karton /  
Boite / Caja / Коробки

Pallet / Pallet / Palette /  
Palette / Pallet / Поддон

	M <sup>2</sup>	KG		M <sup>2</sup>	KG	≠ mm
--	----------------	----	--	----------------	----	---------

### fondi / plain tiles / grundfliesen / fonds / fondos / фоновая плитка

30x90	fondo	5	1,35	23,21	40	54,00	928,63	10
30x90	struttura Gemma 3D	5	1,35	19,16	40	54,00	766,50	10
30x90	struttura Shangai 3D	5	1,35	21,17	40	54,00	847,06	10

### decori / decorative pieces / dekore / décors / decoraciones / декоры

30x30	mosaico	4	0,36	6,40	60	21,60	384,00	10
30x90	decoro Tangram	5	1,35	22,72	40	54,00	909,09	10
30x90	decoro Merletto	2	0,54	9,52				
1x90	listello Titanio	8	0,07	1,50				

# Tempera

30x90

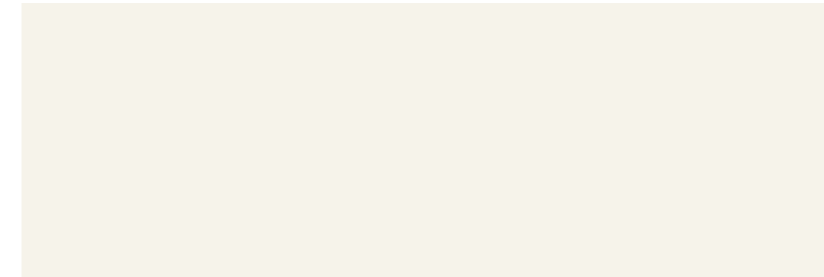

**R6ZR** Tempera Bianco rettificato  
30x90

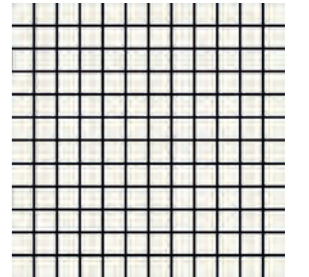

**R70T** Tempera Mosaico Bianco  
30x30

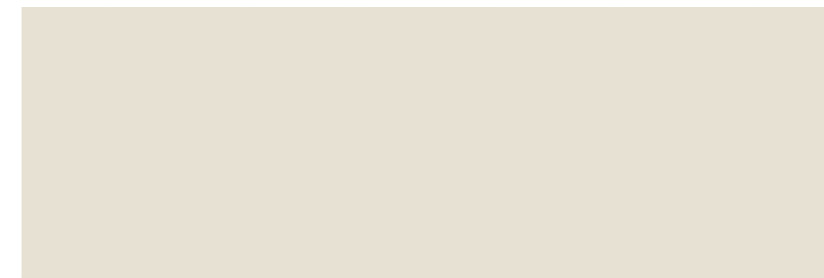

**R6ZP** Tempera Crema rettificato  
30x90

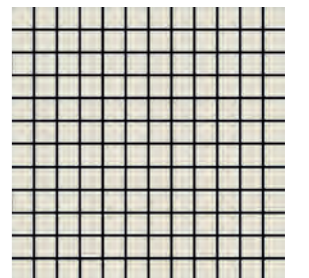

**R70R** Tempera Mosaico Crema  
30x30

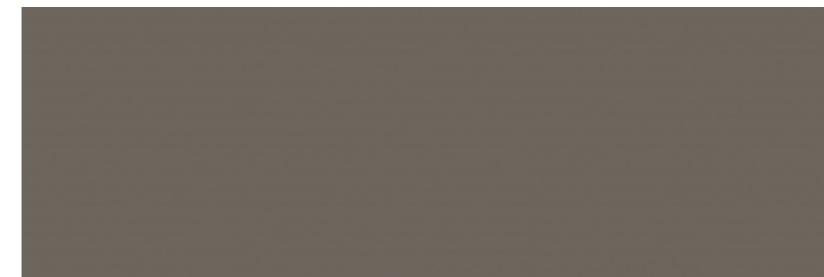

**R6ZN** Tempera Fango rettificato  
30x90

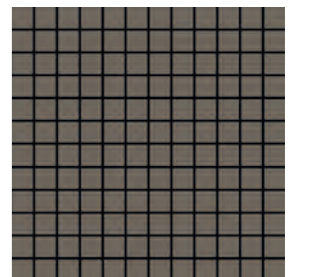

**R70M** Tempera Mosaico Fango  
30x30

**R6ZP** Tempera Crema rettificato 30x90  
**R6ZN** Tempera Fango rettificato 30x90  
**R75Y** Imperiale Listello Titanio 1x90  
**R5QR** Woodstory Bianco rettificato 15x90

# Tempera

30x90



**R6Z5** Tempera Antracite rettificato  
30x90

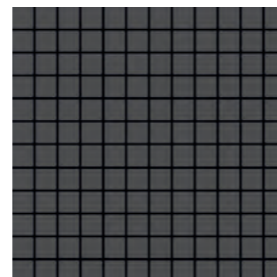

**R70U** Tempera Mosaico Antracite  
30x30



**R707** Tempera Bianco Struttura Shanghai 3D rettificato  
30x90



**R6ZT** Tempera Verde rettificato  
30x90

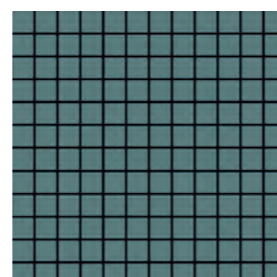

**R70V** Tempera Mosaico Verde  
30x30



**R705** Tempera Crema Struttura Shanghai 3D rettificato  
30x90



**R6ZU** Tempera Blu rettificato  
30x90

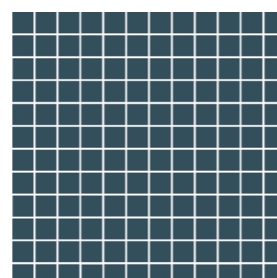

**R70X** Tempera Mosaico Blu  
30x30



**R708** Tempera Verde Struttura Shanghai 3D rettificato  
30x90



**R709** Tempera Blu Struttura Shanghai 3D rettificato  
30x90

# Tempera

30x90



**R6ZZ** Tempera Bianco Struttura Trape 3D rettificato  
30x90

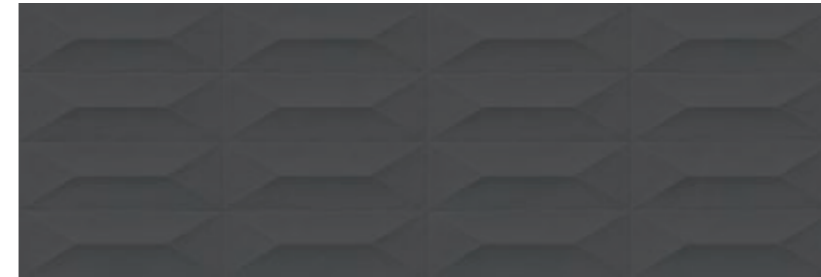

**R700** Tempera Antracite Struttura Trape 3D rettificato  
30x90



**R6ZY** Tempera Crema Struttura Trape 3D rettificato  
30x90



**R701** Tempera Verde Struttura Trape 3D rettificato  
30x90

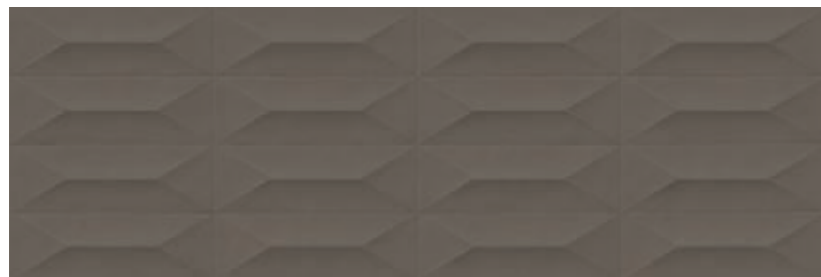

**R6ZW** Tempera Fango Struttura Trape 3D rettificato  
30x90



**R703** Tempera Blu Struttura Trape 3D rettificato  
30x90



# Tempera

30x90

rivestimenti in pasta bianca / white bodywall tiles / wandfliesen aus weissen ton scherben / revetements en pate blanche / revestimientos en pasta blanca / облицовка из белой глины

superfici / surfaces / finitions / oberflächen / superficies / поверхности:  
**matt**

Abbinabile ai fondi / Matching with colours / Mit den Grundfliesen kombinierbar / Peut s'associer aux carreaux de base de couleurs / Puede combinarse con los fondos / Сочетается с фоновой плиткой:

Fango, Crema, Verde



**R70C** Tempera Decoro Time Crema  
30x90

Abbinabile ai fondi / Matching with colours / Mit den Grundfliesen kombinierbar / Peut s'associer aux carreaux de base de couleurs / Puede combinarse con los fondos / Сочетается с фоновой плиткой:

Fango, Crema, Verde



**R76N** Tempera Decoro Tape Crema  
30x90

Abbinabile ai fondi / Matching with colours / Mit den Grundfliesen kombinierbar / Peut s'associer aux carreaux de base de couleurs / Puede combinarse con los fondos / Сочетается с фоновой плиткой:

Bianco, Antracite, Blu



**R70G** Tempera Decoro Time Blu  
30x90

Abbinabile ai fondi / Matching with colours / Mit den Grundfliesen kombinierbar / Peut s'associer aux carreaux de base de couleurs / Puede combinarse con los fondos / Сочетается с фоновой плиткой:

Bianco, Antracite, Blu



**R76P** Tempera Decoro Tape Bianco  
30x90

## tech info



Mosaico assemblato su rete in fibra di vetro  
Mosaic mesh - mounted on fibreglass  
Auf Glasfasernetz geklebtes Mosaik  
Mosaïque montée sur filet en fibre de verre  
Mosaico enmallado sobre fibra de vidrio  
Мозаика, собранная на сетке из стекловолоконна

## imballi / packaging / verpackungen / emballages / embalajes / упаковки

Scatole / Box / Karton /  
Boite / Caja / Коробки

Pallet / Pallet / Palette /  
Palette / Pallet / Поддон



fondi / plain tiles / grundfliesen / fonds / fondos / фоновая плитка						
30x90	fondo	5	1,35	22,20	40	54,00 888,01 10
30x90	struttura Trape 3D	5	1,35	18,77	40	54,00 751,04 10
30x90	struttura Shangai 3D	5	1,35	21,08	40	54,00 843,22 10
decori / decorative pieces / dekore / décors / decoraciones / декоры						
30x30	mosaico	4	0,36	6,40	60	21,60 384,00 10
30x90	decoro Time	5	1,35	21,74	40	54,00 869,57 10
30x90	decoro Tape	2	0,54	10,00		

# Off

30x90



R760 Off Bianco Satinato rettificato 30x90  
R76E Off Bianco Satinato Struttura Gemma 3D rettificato  
R6ZN Tempera Fango rettificato 30x90  
R4NV Replace Tortora rettificato 60x60



# Off

30x90

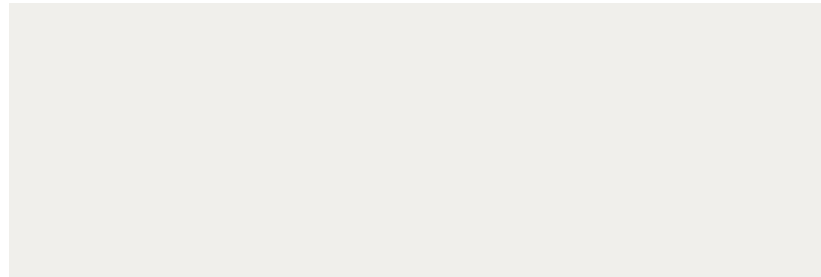

**R760** Off Bianco Satinato rettificato  
30x90



**R76E** Off Bianco Satinato Struttura Gemma 3D rettificato  
30x90



**R76J** Off Bianco Satinato Struttura Shangai 3D rettificato  
30x90

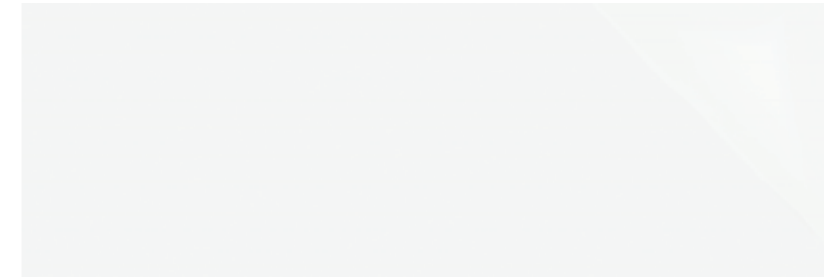

**R76C** Off Bianco Lux rettificato  
30x90



**R76L** Off Bianco Lux Struttura Gemma 3D rettificato  
30x90

**imballi** / packaging / verpackungen / emballages / embalajes / упаковки

Scatole / Box / Karton /  
Boite / Caja / Коробки

Pallet / Pallet / Palette /  
Palette / Pallet / Поддон



**fondi** / plain tiles / grundfliesen / fonds / fondos / фоновая плитка

30x90	fondo / struttura 3D	5	1,35	21,11	40	54,00	844,41	10
-------	----------------------	---	------	-------	----	-------	--------	----

# Flex

25x76



rivestimenti in pasta bianca / white bodywall tiles / wandfliesen aus weissen ton scherben / revetements en pate blanche / revestimientos en pasta blanca / облицовка из белой глины

superfici / surfaces / finitions / oberflächen / superficies / поверхности: **matt**



R02X Flex Cenere 25x76  
R039 Flex Cenere Struttura Brick 3D 25x76  
R4PY Studio Antracite rettificato 60x60

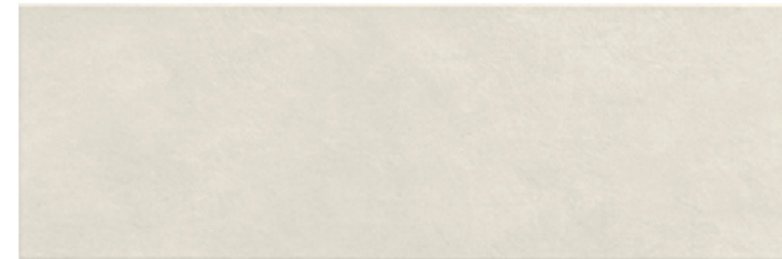

R02W Flex Latte  
25x76



R02X Flex Cenere  
25x76



R037 Flex Crema  
25x76



R03C Flex Latte Struttura Fibra 3D  
25x76



R03G Flex Crema Struttura Fibra 3D  
25x76

# Flex

25x76



**R02Z** Flex Tabacco  
25x76

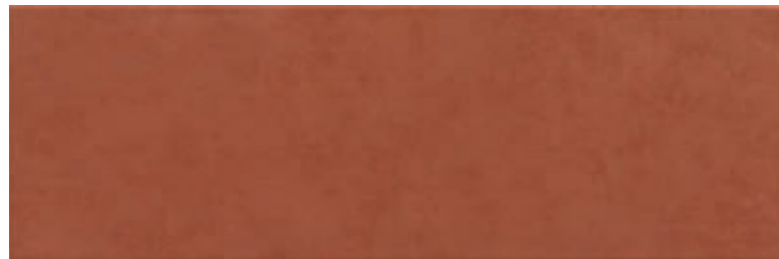

**R036** Flex Zafferano  
25x76

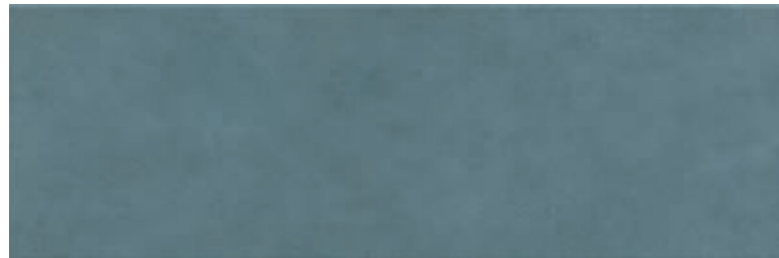

**R02Y** Flex Cielo  
25x76



**R03F** Flex Tabacco Struttura Fibra 3D  
25x76



**R03E** Flex Cielo Struttura Fibra 3D  
25x76



**R038** Flex Latte Struttura Brick 3D  
25x76



**R039** Flex Cenere Struttura Brick 3D  
25x76



**R03A** Flex Crema Struttura Brick 3D  
25x76

# Flex

25x76

rivestimenti in pasta bianca / white bodywall tiles / wandfliesen aus weissen ton scherben / revetements en pate blanche / revestimientos en pasta blanca / облицовка из белой глины

superfici / surfaces / finitions / oberflächen / superficies / поверхности:  
**matt**

Abbinabile ai fondi / Matching with colours / Mit den Grundfliesen kombinierbar / Peut s'associer aux carreaux de base de couleurs / Puede combinarse con los fondos / Сочетается с фоновой плиткой:

Latte, Cenere, Cielo, Zafferano



**R03H** Flex Decoro Fancy Latte  
25x76

Abbinabile ai fondi / Matching with colours / Mit den Grundfliesen kombinierbar / Peut s'associer aux carreaux de base de couleurs / Puede combinarse con los fondos / Сочетается с фоновой плиткой:

Crema, Tabacco, Zafferano



**R03J** Flex Decoro Fancy Crema  
25x76

Abbinabile ai fondi / Matching with colours / Mit den Grundfliesen kombinierbar / Peut s'associer aux carreaux de base de couleurs / Puede combinarse con los fondos / Сочетается с фоновой плиткой:

Latte, Cenere, Cielo

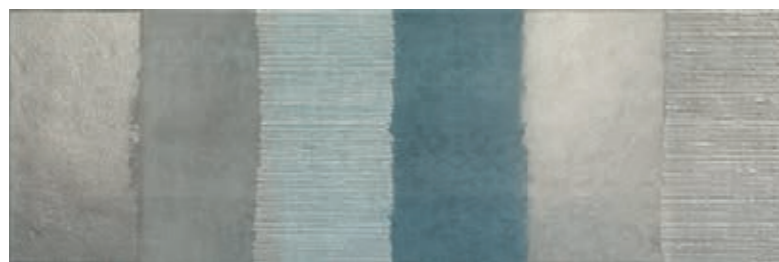

**R125** Flex Decoro Stripe Latte\*  
25x76

Abbinabile ai fondi / Matching with colours / Mit den Grundfliesen kombinierbar / Peut s'associer aux carreaux de base de couleurs / Puede combinarse con los fondos / Сочетается с фоновой плиткой:

Crema, Tabacco



**R12T** Flex Decoro Stripe Crema\*  
25x76

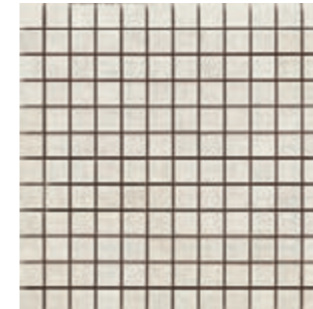

**R06Z** Flex Mosaico Latte  
30x30

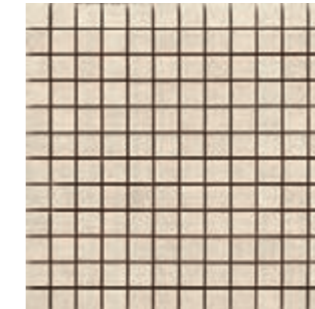

**R07A** Flex Mosaico Crema  
30x30

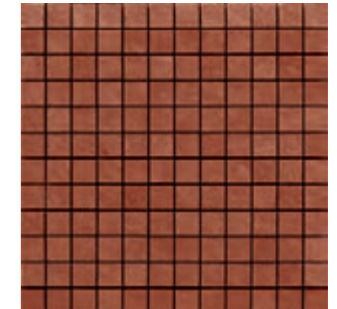

**R07F** Flex Mosaico Zafferano  
30x30

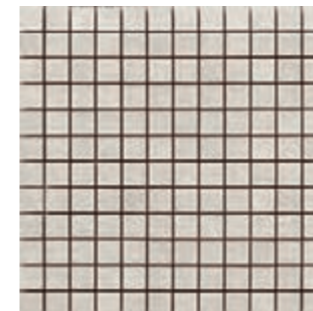

**R07C** Flex Mosaico Cenere  
30x30

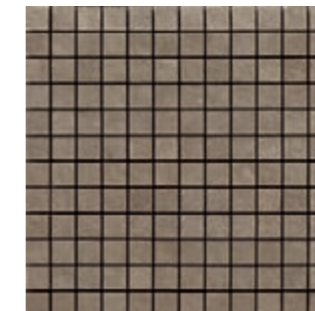

**R07E** Flex Mosaico Tabacco  
30x30

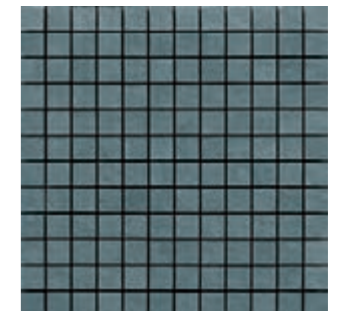

**R07D** Flex Mosaico Cielo  
30x30

## tech info



Mosaico assemblato su rete in fibra di vetro  
Mosaic mesh - mounted on fibreglass  
Auf Glasfasernetz geklebtes Mosaik  
Mosaïque montée sur filet en fibre de verre  
Mosaico enmallado sobre fibra de vidrio  
Мозаика, собранная на сетке из стекловолокон

## \*

Decoro con lustri/metalli preziosi utilizzabile a rivestimento; si consiglia la pulizia con detersivi neutri, non abrasivi. È sconsigliata la posa nell'area doccia. / Decors with lustres/precious metals used for covering; we recommend cleaning with neutral, non-abrasive detergents. Tiles should not be installed in the shower area. / Dekor mit Glanzelementen/Edelmetallen für die Wandverkleidung; es wird die Reinigung mit neutralen, scheuermittelfreien Reinigungsmitteln empfohlen. Die Verlegung in der Duschnische wird nicht empfohlen. / Décor avec lustres/métaux précieux à poser sur le mur. Lavage recommandé avec des détergents neutres, non abrasifs. Pose déconseillée dans la douche. / Decoración con elementos brillantes/metales preciosos utilizable para revestir superficies; se recomienda limpiarla con detergentes neutros, no abrasivos. Se desaconseja colocarla en el área de la ducha. / Декор с блестящим покрытием/драгоценными металлами, используемый для облицовки; рекомендуется чистка с использованием нейтральных, неабразивных моющих средств. Не рекомендуется укладка в душевой зоне.

## imballi / packaging / verpackungen / emballages / embalajes / упаковки

Scatole / Box / Karton / Boite / Caja / Коробки

Pallet / Pallet / Palette / Palette / Pallet / Поддон



## fondi / plain tiles / grundfliesen / fonds / fondos / фоновая плитка

Size	Decor	Boxes	M <sup>2</sup>	KG	Pallets	M <sup>2</sup>	KG	mm
25x76		6	1,14	19,50	54	61,76	1050,00	10
25x76	strutt. Brick 3D	6	1,14	19,50	54	61,76	1050,00	10
25x76	strutt. Fibra 3D	6	1,14	19,50	54	61,76	1050,00	10

## decori / decorative pieces / dekore / décors / decoraciones / декоры

Size	Decor	Boxes	M <sup>2</sup>	KG	Pallets	M <sup>2</sup>	KG	mm
25x76	decoro Fancy	6	1,14	19,50	54	61,76	1050,00	10
25x76	decoro Stripe	2	0,38	4,00				
30x30	mosaico	4	0,36	6,38	60	21,60	383,00	10,5



# Frame

25x76

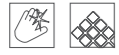

**R4XZ** Frame Milk  
25x76



**R4YA** Frame Cream  
25x76



**R4YC** Frame Khaki  
25x76



**R4YD** Frame Plum  
25x76



**R4YE** Frame Sterling  
25x76



**R4YF** Frame Aqua  
25x76



**R4YG** Frame Indigo  
25x76



# Frame

25x76

**rivestimenti in pasta bianca** / white bodywall tiles / wandfliesen aus weissen ton scherben / revetements en pate blanche / revestimientos en pasta blanca / облицовка из белой глины

**superfici** / surfaces / finitions / oberflächen / superficies / поверхности:  
**glossy**



**R4YH** Frame Milk strutturato  
25x76

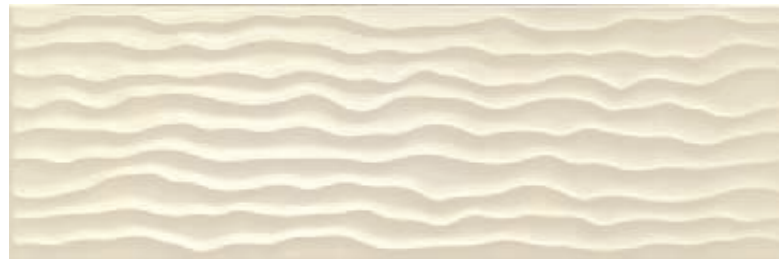

**R4YJ** Frame Cream strutturato  
25x76



**R4YK** Frame Khaki strutturato  
25x76



**R53D** Frame Sterling strutturato  
25x76

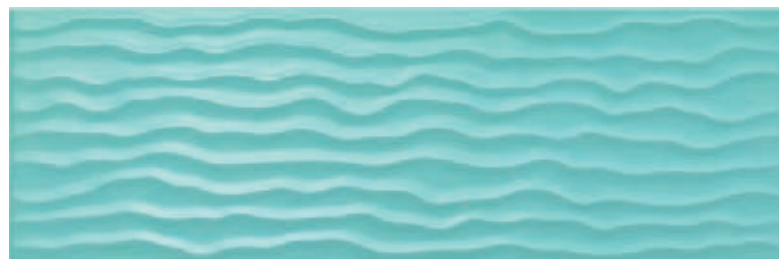

**R4YL** Frame Aqua strutturato  
25x76

Abbinabile ai fondi / Matching with colours / Mit den Grundfliesen kombinierbar / Peut s'associer aux carreaux de base de couleurs / Puede combinarse con los fondos / Сочетается с фоновой плиткой:

Khaki, Plum



**R4YN** Frame Decoro Majolica Cream  
25x76

Abbinabile ai fondi / Matching with colours / Mit den Grundfliesen kombinierbar / Peut s'associer aux carreaux de base de couleurs / Puede combinarse con los fondos / Сочетается с фоновой плиткой:

Aqua, Indigo, Khaki, Sterling



**R4YM** Frame Decoro Majolica Milk  
25x76

Abbinabile ai fondi / Matching with colours / Mit den Grundfliesen kombinierbar / Peut s'associer aux carreaux de base de couleurs / Puede combinarse con los fondos / Сочетается с фоновой плиткой:

Khaki, Plum

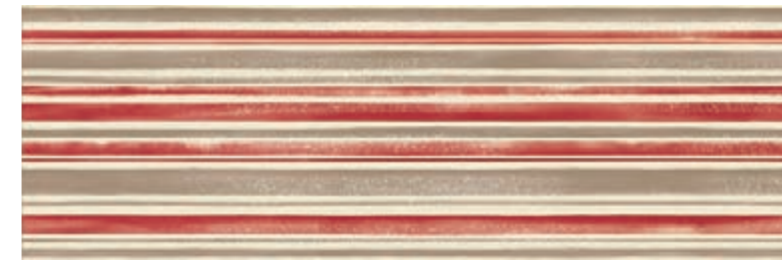

**R50S** Frame Decoro Tratto Cream  
25x76

Abbinabile ai fondi / Matching with colours / Mit den Grundfliesen kombinierbar / Peut s'associer aux carreaux de base de couleurs / Puede combinarse con los fondos / Сочетается с фоновой плиткой:

Aqua, Indigo, Sterling



**R50R** Frame Decoro Tratto Milk  
25x76

# Frame

25x76

rivestimenti in pasta bianca / white bodywall tiles / wandfliesen aus weissen ton scherben / revetements en pate blanche /  
revestimientos en pasta blanca / облицовка из белой глины

superfici / surfaces / finitions / oberflächen / superficies / поверхности:  
glossy

Abbinabile ai fondi / Matching with colours / Mit den Grundfliesen kombinierbar / Peut s'associer aux carreaux  
de base de couleurs / Puede combinarse con los fondos / Сочетается с фоновой плиткой:

Khaki, Plum



**R50U** Frame Decoro C3 Cream  
25x76

Abbinabile ai fondi / Matching with colours / Mit den Grundfliesen kombinierbar / Peut s'associer aux carreaux  
de base de couleurs / Puede combinarse con los fondos / Сочетается с фоновой плиткой:

Indigo, Aqua



**R50T** Frame Decoro C3 Milk  
25x76

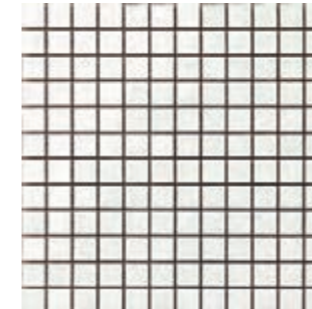

**R4YZ** Frame Mosaico Milk  
30x30

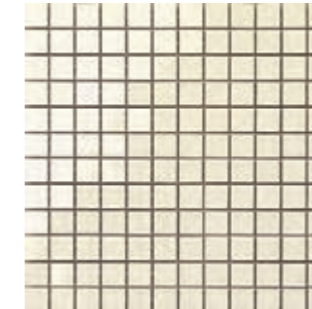

**R4VA** Frame Mosaico Cream  
30x30

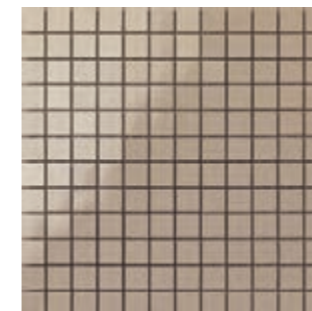

**R4ZC** Frame Mosaico Khaki  
30x30

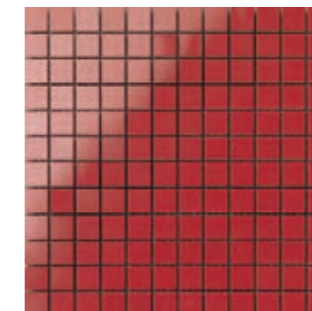

**R4ZD** Frame Mosaico Plum  
30x30

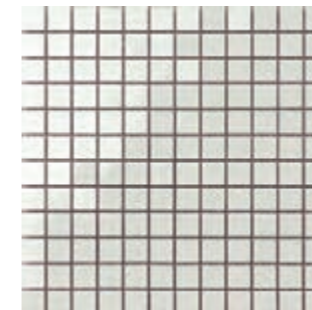

**R4ZE** Frame Mosaico Sterling  
30x30

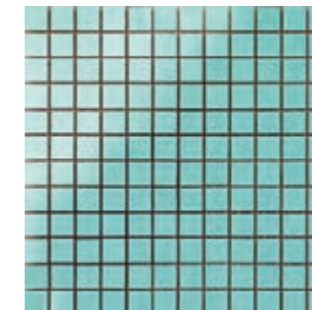

**R4ZF** Frame Mosaico Aqua  
30x30

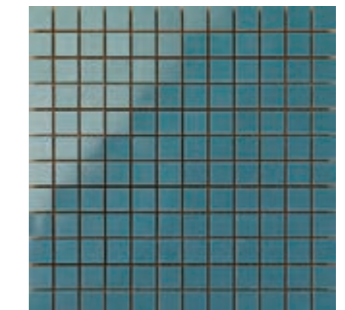

**R4ZG** Frame Mosaico Indigo  
30x30

## tech info



Mosaico assemblato su rete in fibra di vetro  
Mosaic mesh - mounted on fibreglass  
Auf Glasfasernetz geklebtes Mosaik  
Mosaïque montée sur filet en fibre de verre  
Mosaico enmallado sobre fibra de vidrio  
Мозаика, собранная на сетке из стекловолокна

## imballi / packaging / verpackungen / emballages / embalajes / упаковки

Scatole / Box / Karton /  
Boite / Caja / Коробки

Pallet / Pallet / Palette /  
Palette / Pallet / Поддон



## fondi / plain tiles / grundfliesen / fonds / fondos / фоновая плитка

25x76	6	1,14	19,50	54	61,76	1050,00	10
25x76	6	1,14	19,50	54	61,76	1050,00	10

## decori / decorative pieces / dekore / décors / decoraciones / декоры

25x76	decoro Majolica	6	1,14	19,50	54	61,76	1050,00	10
25x76	decoro Tratto	2	0,38	7,53				
25x76	decoro C3	1	0,57	12,32				
30x30	mosaico	4	0,36	9,73	80	28,80	778,36	10,5

# Freestyle

25x76



R6TU Freestyle Matt Struttura Fiore 3D 25x76  
R56E Woodmania Ash 20x120

wall tiles

# Freestyle

25x76



## MATT

**rivestimenti abbinati** / matching wall tiles / passende wandfliesen / revetements assorti / revestimientos combinados / покрытия комбинированный

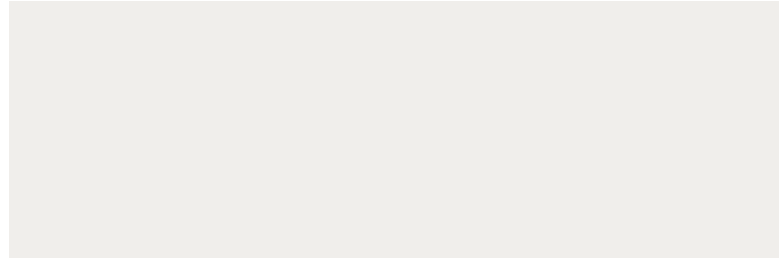

**R2VH** Prestige White Matt  
25x76



**R6SA** Freestyle Matt Struttura Curva 3D  
25x76



**R6TU** Freestyle Matt Struttura Fiore 3D  
25x76



**R02C** Freestyle Matt Struttura Fibra 3D  
25x76

**rivestimenti in pasta bianca** / white bodywall tiles / wandfliesen aus weissen ton scherben / revetements en pate blanche / revestimientos en pasta blanca / облицовка из белой глины

**superfici** / surfaces / finitions / oberflächen / superficies / поверхности:  
**matt+glossy**

## GLOSSY

**rivestimenti abbinati** / matching wall tiles / passende wandfliesen / revetements assorti / revestimientos combinados / покрытия комбинированный

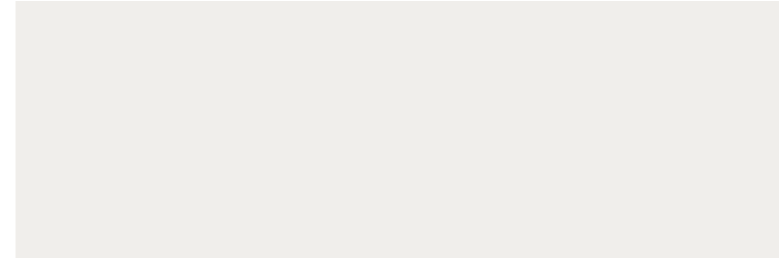

**R2VF** Prestige White Glossy  
25x76



**R5QY** Freestyle Glossy Struttura Curva 3D  
25x76



**R75H** Freestyle Glossy Struttura Fiore 3D  
25x76

**imballi** / packaging / verpackungen / emballages / embalajes / упаковки

Scatole / Box / Karton / Boite / Caja / Коробки			Pallet / Pallet / Palette / Palette / Pallet / Поддон			
□	M <sup>2</sup>	KG	□	M <sup>2</sup>	KG	≠ mm

**fondi** / plain tiles / grundfliesen / fonds / fondos / фоновая плитка

25x76	6	1,14	19,50	54	61,76	1050,00	10
25x76	6	1,14	19,50	54	61,76	1050,00	10

# Rewind

25x76



R4WT Rewind Argilla 25x76  
R4WS Rewind Corda 25x76  
R4WX Rewind Corda strutturato 25x76  
R4YV Rewind Mosaico Argilla 30x30  
R4WE Woodlike Walnut 15x90

wall tiles

# Rewind

25x76



**R4WS** Rewind Corda  
25x76



**R4WT** Rewind Argilla  
25x76



**R4WV** Rewind Vanilla  
25x76

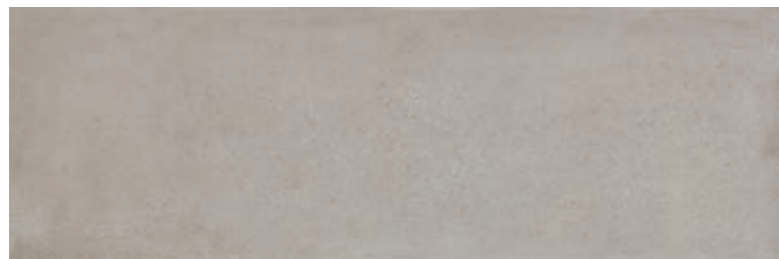

**R4WW** Rewind Polvere  
25x76



**R4WU** Rewind Peltro  
25x76



**R4WX** Rewind Corda strutturato  
25x76

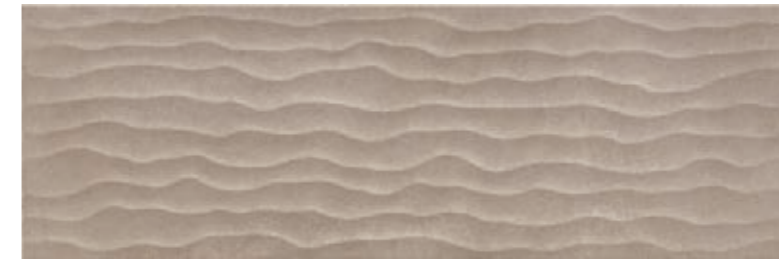

**R4WY** Rewind Argilla strutturato  
25x76



**R4XA** Rewind Vanilla strutturato  
25x76

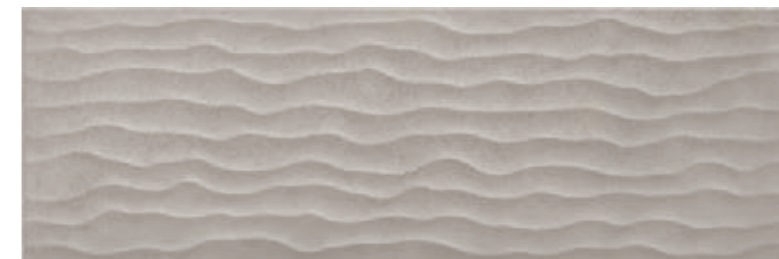

**R4XC** Rewind Polvere strutturato  
25x76

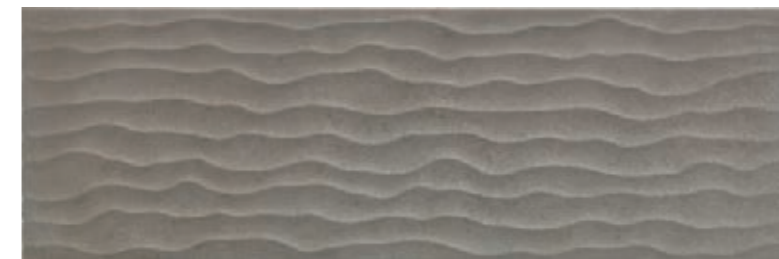

**R4WZ** Rewind Peltro strutturato  
25x76

# Rewind

25x76

**rivestimenti in pasta bianca** / white bodywall tiles / wandfliesen aus weissen ton scherben / revetements en pate blanche / revestimientos en pasta blanca / облицовка из белой глины

**superfici** / surfaces / finitions / oberflächen / superficies / поверхности:  
**matt**

Abbinabile ai fondi / Matching with colours / Mit den Grundfliesen kombinierbar / Peut s'associer aux carreaux de base de couleurs / Puede combinarse con los fondos / Сочетается с фоновой плиткой:

Argilla, Peltro



**R4XD** Rewind Decoro Corda  
25x76

Abbinabile ai fondi / Matching with colours / Mit den Grundfliesen kombinierbar / Peut s'associer aux carreaux de base de couleurs / Puede combinarse con los fondos / Сочетается с фоновой плиткой:

Polvere, Peltro



**R4XE** Rewind Decoro Vanilla  
25x76

Abbinabile ai fondi / Matching with colours / Mit den Grundfliesen kombinierbar / Peut s'associer aux carreaux de base de couleurs / Puede combinarse con los fondos / Сочетается с фоновой плиткой:

Argilla



**R4ZZ** Rewind Decoro Corda  
25x76

Abbinabile ai fondi / Matching with colours / Mit den Grundfliesen kombinierbar / Peut s'associer aux carreaux de base de couleurs / Puede combinarse con los fondos / Сочетается с фоновой плиткой:

Polvere, Peltro



**R500** Rewind Decoro Vanilla  
25x76

Abbinabile ai fondi / Matching with colours / Mit den Grundfliesen kombinierbar / Peut s'associer aux carreaux de base de couleurs / Puede combinarse con los fondos / Сочетается с фоновой плиткой:

Argilla



**R501** Rewind Decoro C3 Corda  
25x76

Abbinabile ai fondi / Matching with colours / Mit den Grundfliesen kombinierbar / Peut s'associer aux carreaux de base de couleurs / Puede combinarse con los fondos / Сочетается с фоновой плиткой:

Polvere



**R502** Rewind Decoro C3 Vanilla  
25x76

# Rewind

25x76

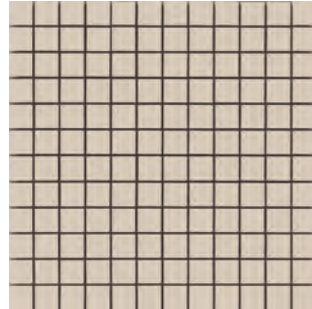

**R4YU** Rewind Mosaico Corda  
30x30

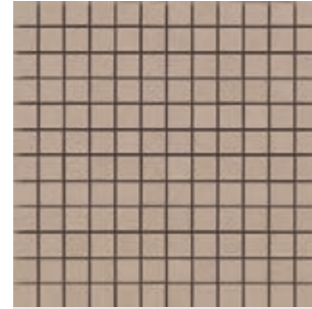

**R4YV** Rewind Mosaico Argilla  
30x30

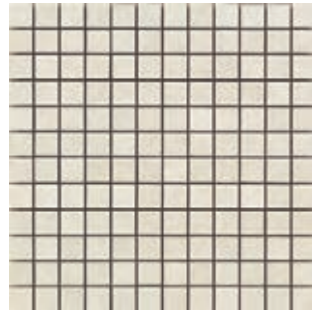

**R4YX** Rewind Mosaico Vanilla  
30x30

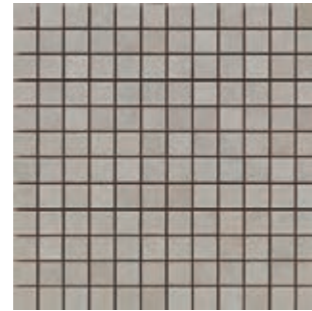

**R4YY** Rewind Mosaico Polvere  
30x30

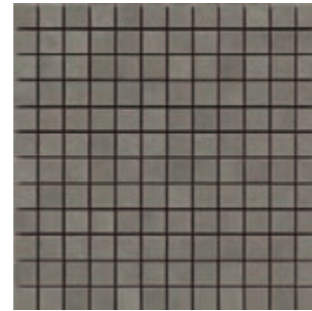

**R4YW** Rewind Mosaico Peltro  
30x30

## tech info



Mosaico assemblato su rete in fibra di vetro  
Mosaic mesh - mounted on fibreglass  
Auf Glasfasernetz geklebtes Mosaik  
Mosaïque montée sur filet en fibre de verre  
Mosaico enmallado sobre fibra de vidrio  
Мозаика, собранная на сетке из стекловолокну

## imballi / packaging / verpackungen / emballages / embalajes / упаковки

Scatole / Box / Karton /  
Boite / Caja / Коробки

Pallet / Pallet / Palette /  
Palette / Pallet / Поддон



### fondi / plain tiles / grundfliesen / fonds / fondos / фоновая плитка

25x76		6	1,14	19,50	54	61,76	1050,00	10
25x76	strutturato	6	1,14	19,50	54	61,76	1050,00	10

### decori / decorative pieces / dekore / décors / decoraciones / декоры

25x76	decoro	6	1,14	20,40	54	61,56	1103,00	10
25x76	decoro	2	0,38	7,53				
25x76	decoro C3	1	0,57	12,32				
30x30	mosaico	4	0,36	9,60	80	28,80	767,99	10,5



# Trama

25x76



R5K9 Trama Bianco 25x76  
R5KQ Trama Bianco Struttura Fibra 3D 25x76  
R5S9 Woodreal Beige 10x100-13x100

wall tiles

# Trama

25x76



**RSK9** Trama Bianco  
25x76

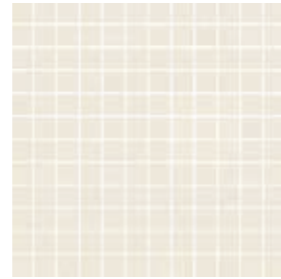

**RSUW** Trama Mosaico Bianco  
30x30



**RSKC** Trama Avio  
25x76

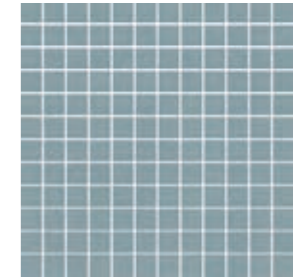

**RSUU** Trama Mosaico Avio  
30x30

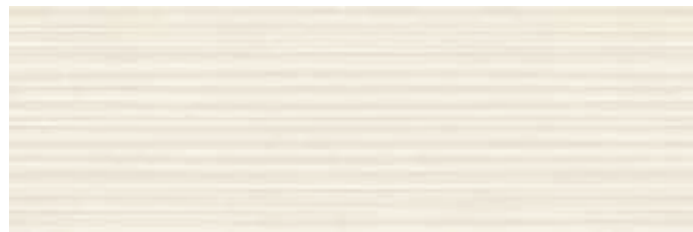

**RSKQ** Trama Bianco Struttura Fibra 3D  
25x76



**RSKS** Trama Avio Struttura Fibra 3D  
25x76



**RSKA** Trama Grigio  
25x76

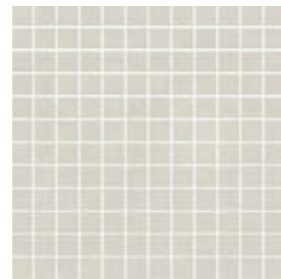

**RSUV** Trama Mosaico Grigio  
30x30

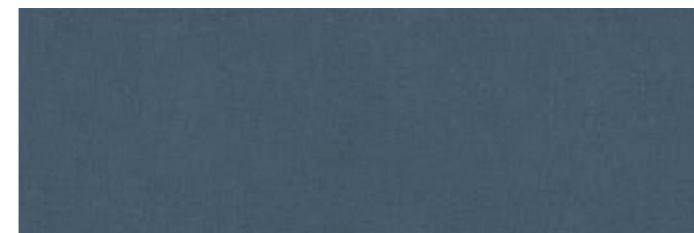

**RSKD** Trama Blu  
25x76

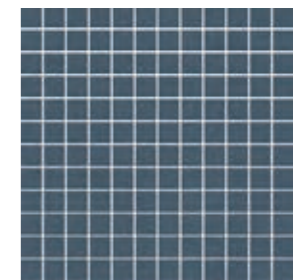

**RSTQ** Trama Mosaico Blu  
30x30



**RSKR** Trama Grigio Struttura Fibra 3D  
25x76



**RSRU** Trama Blu Struttura Fibra 3D  
25x76

# Trama

25x76

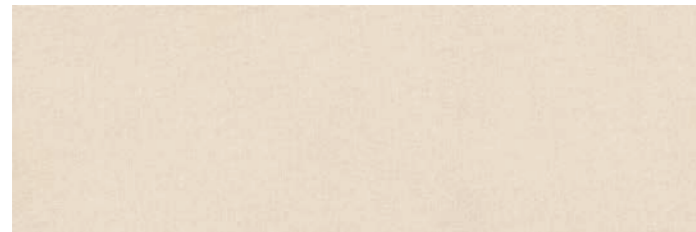

**R5KG** Trama Avorio  
25x76

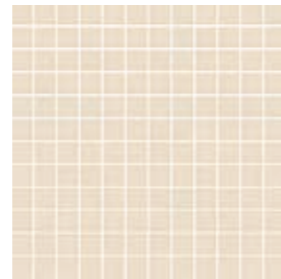

**R5TM** Trama Mosaico Avorio  
30x30

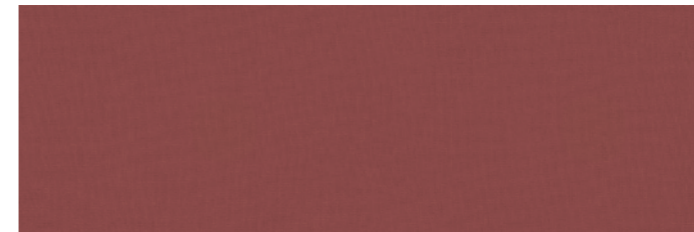

**R5KE** Trama Rosso  
25x76

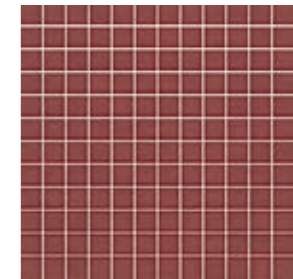

**R5TP** Trama Mosaico Rosso  
30x30



**R5KT** Trama Avorio Struttura Fibra 3D  
25x76



**R5RT** Trama Rosso Struttura Fibra 3D  
25x76

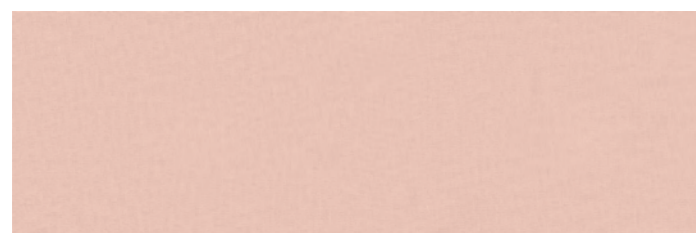

**R5KF** Trama Rosa  
25x76

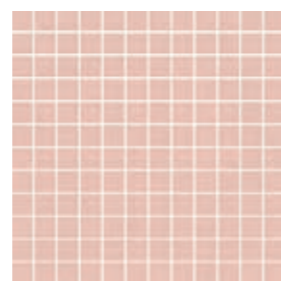

**R5TN** Trama Mosaico Rosa  
30x30



**R5KU** Trama Rosa Struttura Fibra 3D  
25x76

Abbinabile ai fondi / Matching with colours / Mit den Grundfliesen kombinierbar / Peut s'associer aux carreaux de base de couleurs / Puede combinarse con los fondos / Сочетается с фоновой плиткой:  
Avorio, Rosa, Rosso



**R627** Trama Decoro Filato Avorio  
25x76

Abbinabile ai fondi / Matching with colours / Mit den Grundfliesen kombinierbar / Peut s'associer aux carreaux de base de couleurs / Puede combinarse con los fondos / Сочетается с фоновой плиткой:  
Bianco, Grigio, Avio, Blu



**R628** Trama Decoro Filato Bianco  
25x76

# Trama

25x76

Abbinabile ai fondi / Matching with colours / Mit den Grundfliesen kombinierbar / Peut s'associer aux carreaux de base de couleurs / Puede combinarse con los fondos / Сочетается с фоновой плиткой:

Bianco, Grigio, Avio, Blu



**RSKX** Trama Decoro Arazzo Bianco  
25x76

Abbinabile ai fondi / Matching with colours / Mit den Grundfliesen kombinierbar / Peut s'associer aux carreaux de base de couleurs / Puede combinarse con los fondos / Сочетается с фоновой плиткой:

Bianco, Avio, Blu



**RSKV** Trama Decoro Stuoia Bianco  
25x76

Abbinabile ai fondi / Matching with colours / Mit den Grundfliesen kombinierbar / Peut s'associer aux carreaux de base de couleurs / Puede combinarse con los fondos / Сочетается с фоновой плиткой:

Bianco, Rosa, Rosso

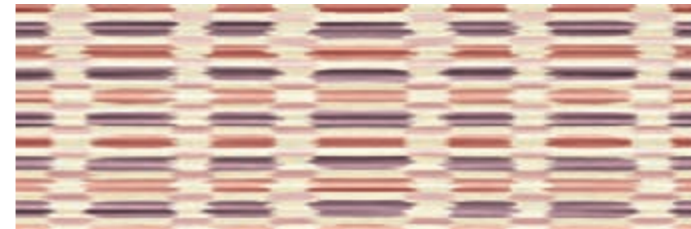

**RSKW** Trama Decoro Stuoia Rosa  
25x76

Abbinabile ai fondi / Matching with colours / Mit den Grundfliesen kombinierbar / Peut s'associer aux carreaux de base de couleurs / Puede combinarse con los fondos / Сочетается с фоновой плиткой:

Avorio, Rosa, Rosso



**RSKY** Trama Decoro Arazzo Avorio  
25x76

## tech info



Mosaico assemblato su rete in fibra di vetro  
Mosaic mesh - mounted on fibreglass  
Auf Glasfasernetz geklebtes Mosaik  
Mosaïque montée sur filet en fibre de verre  
Mosaico emmallado sobre fibra de vidrio  
Мозаика, собранная на сетке из стекловолокна

## imballi / packaging / verpackungen / emballages / embalajes / упаковки

Scatole / Box / Karton /  
Boite / Caja / Коробки

Pallet / Pallet / Palette /  
Palette / Pallet / Поддон



### fondi / plain tiles / grundfliesen / fonds / fondos / фоновая плитка

25x76		6	1,14	19,50	54	61,56	1050,00	10
25x76	strutt. Fibra	6	1,14	19,50	54	61,56	1050,00	10

### decori / decorative pieces / dekore / décors / decoraciones / декоры

25x76	decoro Stuoia	6	1,14	19,50	54	61,56	1050,00	10
25x76	decoro Arazzo	6	1,14	19,50	54	61,56	1050,00	10
25x76	decoro Filato	2	0,38	7,53				
30x30	mosaico	4	0,36	6,40	60	21,60	384,00	10

# Fantasy

30x60



R57V Fantasy Bianco Lux rettificato 30x60  
R57J Fantasy Bianco Lux Struttura Drappo 3D rettificato 30x60  
R56E Woodmania Ash 20x120  
R56Q Woodmania Ash Outdoor 20x120

# Fantasy

30x60

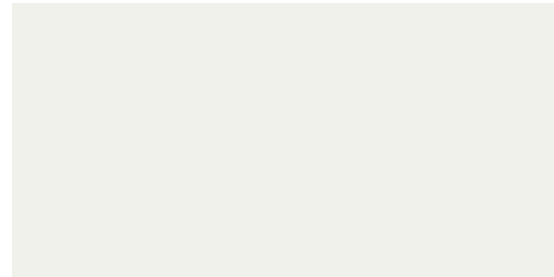

**R57U** Fantasy Bianco Satinato rettificato  
30x60

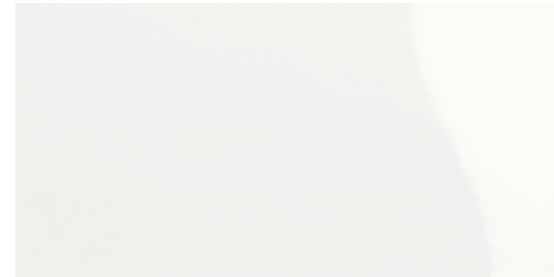

**R57V** Fantasy Bianco Lux rettificato  
30x60



**R02P** Fantasy Decoro Vintage Bianco  
30x60



**R57F** Fantasy Bianco Satinato Struttura Prisma 3D rettificato  
30x60



**R57G** Fantasy Bianco Lux Struttura Prisma 3D rettificato  
30x60

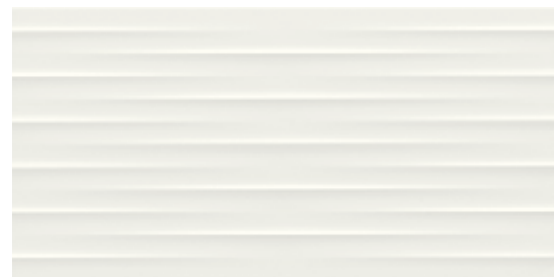

**R57H** Fantasy Bianco Satinato Struttura Drappo 3D rettificato  
30x60



**R57J** Fantasy Bianco Lux Struttura Drappo 3D rettificato  
30x60



**R01H** Fantasy Mosaico Bianco  
30x30



**R57E** Fantasy Bianco Satinato Struttura Onda 3D rettificato  
30x60

## tech info



Mosaico assemblato su rete in fibra di vetro  
Mosaic mesh - mounted on fibreglass  
Auf Glasfasernetz geklebtes Mosaik  
Mosaïque montée sur filet en fibre de verre  
Mosaico enmallado sobre fibra de vidrio  
Мозаика, собранная на сетке из стекловолоконна

## imballi / packaging / verpackungen / emballages / embalajes / упаковки

Scatole / Box / Karton / Boite / Caja / Коробки Pallet / Pallet / Palette / Palette / Поддон



## fondi / plain tiles / grundfliesen / fonds / fondos / фоновая плитка

30x60	6	1,08	12,80	64	69,12	820,00	6
30x60 struttura 3D	4	0,72	9,40	64	46,08	602,00	8

## decori / decorative pieces / dekore / décors / decoraciones / декоры

30x30 mosaico	6	0,54	7,83	80	43,20	626,00	6
30x60 decoro	4	0,72	8,80				6



*Home Line*  
**FLOOR**

*Gres Porcellanato*  
*Porcelain stoneware*  
*Feinsteinzeug*  
*Grès cérame*  
*Gres porcelánico*  
*Керамогранит*

# Creek

60x120 60x60 30x60 45x45



**H** Naturale/Matt  
**H** Strutturato



**H** Naturale/Matt  
**H** Strutturato



**H** Naturale/Matt  
**H** Strutturato



**H** Naturale/Matt  
**H** Strutturato



**R5K0** Creek Bianco rettificato

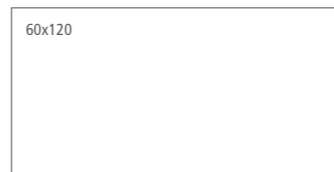

**R5JZ** Creek Grigio rettificato



**R5JY** Creek Antracite rettificato

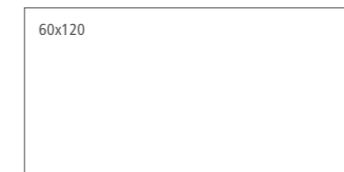

**R5K1** Creek Avorio rettificato

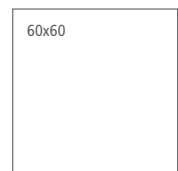

**R4EF** Creek Bianco rettificato

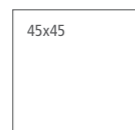

**R5J4** Creek Bianco

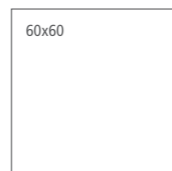

**R4EE** Creek Grigio rettificato

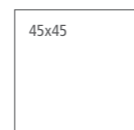

**R5J3** Creek Grigio



**R4ED** Creek Antracite rettificato

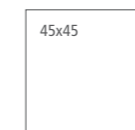

**R5J2** Creek Antracite



**R4EG** Creek Avorio rettificato

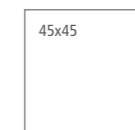

**R5J5** Creek Avorio



**R4HM** Creek Bianco rettificato  
**R4NP** Creek Bianco strutturato rettificato

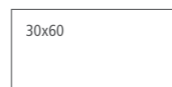

**R4HL** Creek Grigio rettificato  
**R4NN** Creek Grigio strutturato rettificato

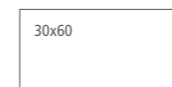

**R4HK** Creek Antracite rettificato  
**R4NM** Creek Antracite strutturato rettificato



**R4HN** Creek Avorio rettificato  
**R4NQ** Creek Avorio strutturato rettificato



# Creek

60x120 60x60 30x60 45x45



**H** Naturale/Matt

**H** Strutturato

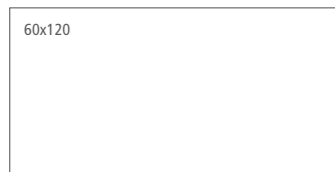

**R5K2** Creek Beige rettificato

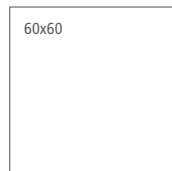

**R4EH** Creek Beige rettificato

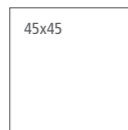

**R5J6** Creek Beige

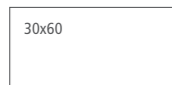

**R4KX** Creek Beige rettificato

**R4NR** Creek Beige strutturato rettificato



**R5HY** Creek Decoro Classic Grigio rettificato  
60x60

**H**



**R5HZ** Creek Decoro Classic Avorio rettificato  
60x60

**H**



**R5LU** Creek Mosaico Bianco  
30x30



**R5LT** Creek Mosaico Grigio  
30x30



**R5LS** Creek Mosaico Antracite  
30x30



**R5LV** Creek Mosaico Avorio  
30x30



**R5LW** Creek Mosaico Beige  
30x30

## tech info

\*

Battiscopa ottenuto da taglio del fondo / Skirting cut from plain tile / Aus Grundfliese geschnittener Sockel / Plinthe obtenue par découpe du fond / Rodapié obtenido mediante corte del fondo / Плинтус, полученный методом нарезания фоновой плитки

\*\*

Assemblato (pag. 592) / Two-piece L-tile (page 592) / Randstein zweiteilig (S. 592) / Assemblé (page 592) / Montado (pág. 592) / Собранный (стр. 592)



Mosaico assemblato con tratto plastico / Spot-bonded mosaic / Punktverklebtes Mosaik / Mosaïque montée avec trait de colle / Mosaico colocado aplicando cola plástica / Мозаика с сегментами, выполненными из пластмассы - Мозаика, собранная на клеевой точке



Apprezzabili differenze nell'aspetto di superficie e grafica all'interno della stessa produzione. / Clearly distinguishable differences in texture and pattern within the same production run. / Auffällige Unterschiede in Aussehen und Struktur innerhalb der gleichen Produktionscharge. / Différences visibles au niveau de l'aspect et de la fantaisie entre les carreaux du même lot de production. / Diferencias visibles en el aspecto de la superficie y los motivos dentro de un mismo lote de producción. / Заметные отличия вида поверхности и графики в одной и той же партии.



Vedi Appendice pag. 585  
See Appendix page 585  
Siehe Anhang S. 585  
Voir Annexe page 585  
Véase la pág. 585 del Apéndice  
Смотри приложение на стр. 585

## pezzi speciali / trims / spezialteile / pièces spéciales / piezas especiales / специальные изделия



BT.B.C.\*  
8x45



BT.B.C.\*  
7x60



E.ELLE strutturato\*\*  
15x60

Creek Bianco	R77Q	R5MX	R5LZ
Creek Grigio	R77R	R5MV	R5LY
Creek Antracite	R77S	R5MU	R5LX
Creek Avorio	R77T	R5MY	R5MA
Creek Beige	R77U	R5MZ	R5MC

## imballi / packaging / verpackungen / emballages / embalajes / упаковки

Scatole / Box / Karton / Boite / Caja / Коробки Pallet / Pallet / Palette / Palette / Pallet / Поддон



fondi / plain tiles / grundfliesen / fonds / fondos / фоновая плитка							
60x120	2	1,44	31,47	36	51,84	1132,85	9,5
60x60	3	1,08	23,00	40	43,20	920,13	9,5
45x45	5	1,01	22,00	33	33,41	726,04	9
30x60 naturale / strutturato	6	1,08	22,99	48	51,84	1103,92	9,5

decori / decorative pieces / dekore / décors / decoraciones / декоры							
60x60 decoro	3	1,08	21,43	40	43,20	857,14	9,5
30x30 mosaico	4	0,36	8,00	80	28,80	640,00	9,5

pezzi speciali / trims / spezialteile / pièces spéciales / piezas especiales / специальные изделия							
15x60 E.ELLE strutt.	4	0,36	8,00				
7x60 BT.B.C.	15	9,00 ml	14,00				9,5
8x45 BT.B.C.	30	13,50 ml	20,20				9

# Replace

60x120 60x60 30x60 45x45



**H** Naturale/Matt  
**H** Strutturato



**R48Q** Replace Bianco rettificato

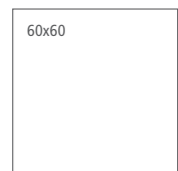

**R4NV** Replace Bianco rettificato  
**R5JF** Replace Bianco C2 rettificato \*

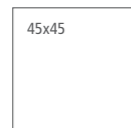

**R55K** Replace Bianco



**R4PF** Replace Bianco rettificato  
**R4QE** Replace Bianco strutturato rettificato



**H** Naturale/Matt  
**H** Strutturato



**R47Y** Replace Grigio rettificato

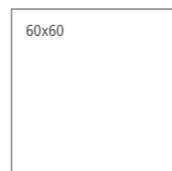

**R4NT** Replace Grigio rettificato  
**R5JD** Replace Grigio C2 rettificato \*

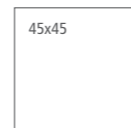

**R55J** Replace Grigio



**R4PE** Replace Grigio rettificato  
**R4QD** Replace Grigio strutturato rettificato



**H** Naturale/Matt  
**H** Strutturato



**R47S** Replace Antracite rettificato



**R4NS** Replace Antracite rettificato  
**R5JA** Replace Antracite C2 rettificato \*

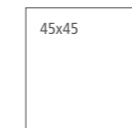

**R52J** Replace Antracite

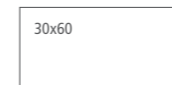

**R4PD** Replace Antracite rettificato  
**R4QC** Replace Antracite strutturato rettificato



**G** Naturale/Matt  
**G** Strutturato



**R48T** Replace Beige rettificato



**R4NW** Replace Beige rettificato  
**R5JG** Replace Beige C2 rettificato \*

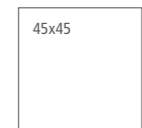

**R55L** Replace Beige



**R4PG** Replace Beige rettificato  
**R4VY** Replace Beige strutturato rettificato

# Replace

60x120 60x60 30x60 45x45



**H** Naturale/Matt

**H** Strutturato

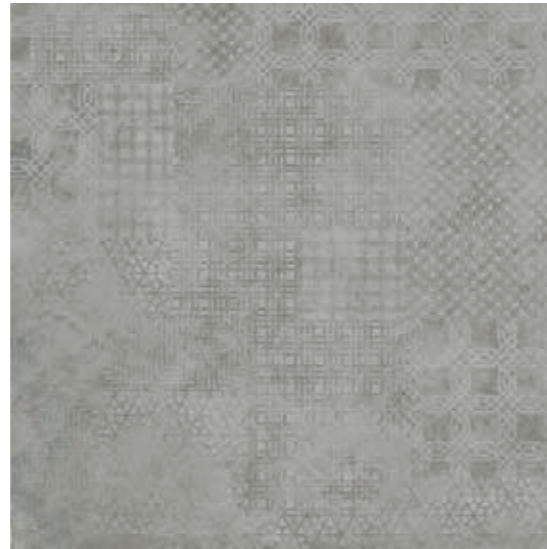

**R5J0** Replace Decoro Moderno Grigio rettificato 60x60

**H**



**R48N** Replace Tortora rettificato

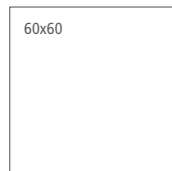

**R4NU** Replace Tortora rettificato  
**R5JH** Replace Tortora C2 rettificato \*

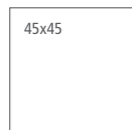

**R55M** Replace Tortora



**R4PH** Replace Tortora rettificato  
**R4VZ** Replace Tortora strutturato rettificato



**R5J1** Replace Decoro Moderno Beige rettificato 60x60

**G**



**R5ML** Replace Mosaico Bianco 30x30

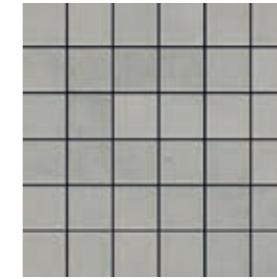

**R5MK** Replace Mosaico Grigio 30x30



**R5MJ** Replace Mosaico Antracite 30x30

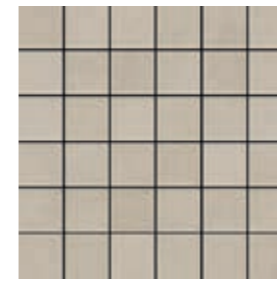

**R5MM** Replace Mosaico Beige 30x30



**R5MN** Replace Mosaico Tortora 30x30

## tech info

\*

C2: Classificazione in base alla normativa spagnola UNE – ENV 12633:2003 / Classification according to Spanish standard UNE - ENV 12633: 2003 / Klassifizierung gemäß der spanischen Norm UNE – ENV 12633:2003 / Classification selon la norme espagnole UNE-ENV 12633:2003 / Clasificación con arreglo a la norma española UNE – ENV 12633:2003 / Классификация в соответствии с испанским стандартом UNE – ENV 12633:2003

\*\*

Battiscopa ottenuto da taglio del fondo / Skirting cut from plain tile / Aus Grundfliese geschnittener Sockel / Plinthe obtenue par découpe du fond / Rodapié obtenido mediante corte del fondo / Плинтус, полученный методом нарезания фоновой плитки

\*\*\*

Assemblato (pag. 592) / Two-piece L-tile (page 592) / Randstein zweiteilig (S. 592) / Assemblé (page 592) / Montado (pág. 592) / Собираемая (стр. 592)



Mosaico assemblato con tratto plastico / Spot-bonded mosaic / Punktverklebtes Mosaik / Mosaïque montée avec trait de colle / Mosaico colocado aplicando cola plástica / Мозаика с сегментами, выполненными из пластмассы - Мозаика, собранная на клеевой точке



Apprezzabili differenze nell'aspetto di superficie e grafica all'interno della stessa produzione. / Clearly distinguishable differences in texture and pattern within the same production run. / Auffällige Unterschiede in Aussehen und Struktur innerhalb der gleichen Produktionscharge. / Différences visibles au niveau de l'aspect et de la fantaisie entre les carreaux du même lot de production. / Diferencias visibles en el aspecto de la superficie y los motivos dentro de un mismo lote de producción. / Заметные отличия вида поверхности и графики в одной и той же партии.



Vedi Appendice pag. 585  
See Appendix page 585  
Siehe Anhang S. 585  
Voir Annexe page 585  
Véase la pág. 585 del Apéndice  
Смотри приложение на стр. 585

pezzi speciali / trims / spezialteile / pièces spéciales / piezas especiales / специальные изделия



Replace Bianco	R77F	R5ND	R5MR
Replace Grigio	R77G	R5NC	R5MQ
Replace Antracite	R77H	R5NA	R5MP
Replave Beige	R77J	R5NE	R5MS
Replace Tortora	R77K	R5NF	R5MT

## imballi / packaging / verpackungen / emballages / embalajes / упаковки

Scatole / Box / Karton / Bolte / Caja / Коробки	M <sup>2</sup>	KG	Pallet / Pallet / Palette / Palette / Поддон	M <sup>2</sup>	KG	≠ mm
---	----------------	----	--	----------------	----	------

fondi / plain tiles / grundfliesen / fonds / fondos / фоновая плитка							
60x120	2	1,44	31,47	36	51,84	1132,85	9,5
60x60	3	1,08	23,00	40	43,20	920,13	9,5
45x45	5	1,01	22,00	33	33,41	726,04	9
30x60 naturale / strutturato	6	1,08	22,99	48	51,84	1103,92	9,5

decori / decorative pieces / dekore / décors / decoraciones / декоры							
60x60 decoro	3	1,08	21,93	40	43,20	877,14	9,5
30x30 mosaico	4	0,36	8,00	80	28,80	640,00	9,5

pezzi speciali / trims / spezialteile / pièces spéciales / piezas especiales / специальные изделия							
15x60 E.ELLE strutt.	4	0,36	8,00				
7x60 BT.B.C.	15	9 ml	14,00				9,5
8x45 BT.B.C.	30	13,50 ml	20,20				9

# Casablanca

60x60 30x60 45x45 33,3x33,3

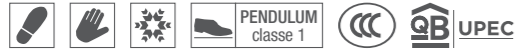

Gruppo Bla UNI EN 14411\_G

gres porcellanato - rettificato monocalibro / porcelain stoneware - rectified monocaliber / feinsteinzeug - rektifiziert, in einem werkmaß / grès cérame émaillé - rectifié monocalibre / gres porcelánico - rectificado monocalibre / керамогранит - ректифицированный монокалиберный

45x45 - 33,3x33,3

gres porcellanato / porcelain stoneware / feinsteinzeug / grès cérame émaillé / gres porcelánico / керамогранит

superfici / surfaces / finitions / oberflächen / superficies / поверхности:  
naturale/matt



G

**R3KM** Casablanca BG rettificato  
60x60

**R3KZ** Casablanca BG  
45x45

**R51P** Casablanca BG  
33,3x33,3



G

**R3KN** Casablanca CR rettificato  
60x60

**R3LA** Casablanca CR  
45x45

**R51Q** Casablanca CR  
33,3x33,3



F

**R3KP** Casablanca MA rettificato  
60x60

**R3LC** Casablanca MA  
45x45

**R51R** Casablanca MA  
33,3x33,3



G

**R3KQ** Casablanca GR rettificato  
60x60

**R3LD** Casablanca GR  
45x45

**R51S** Casablanca GR  
33,3x33,3



G

**R3KT** Casablanca BG rettificato  
30x60

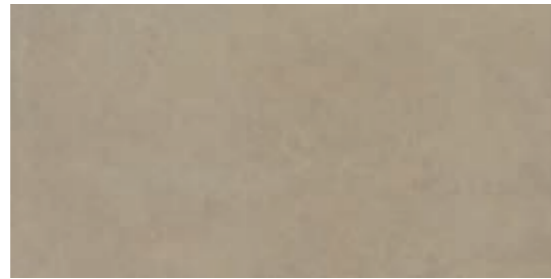

G

**R3KU** Casablanca CR rettificato  
30x60

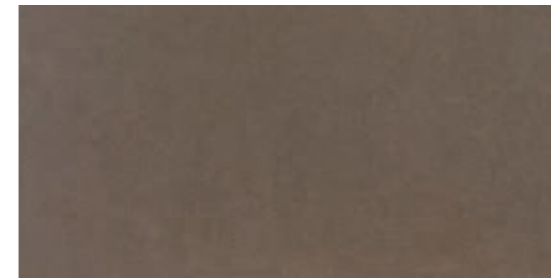

F

**R3KV** Casablanca MA rettificato  
30x60



G

**R3KW** Casablanca GR rettificato  
30x60

# Casablanca

60x60 30x60 45x45 33,3x33,3



G

**R3KR** Casablanca AN rettificato  
60x60

**R3LE** Casablanca AN  
45x45

**R51T** Casablanca AN  
33,3x33,3



F

**R3KS** Casablanca NE rettificato  
60x60

**R3LF** Casablanca NE  
45x45

**R51U** Casablanca NE  
33,3x33,3



G

**R3KX** Casablanca AN rettificato  
30x60



F

**R3KY** Casablanca NE rettificato  
30x60

## tech info

\*

Battiscopa ottenuto per pressatura  
Pressed skirting tile  
Gepresster Sockel  
Plinthe obtenue par pressage  
Rodapié obtenido mediante prensado  
Плинтус, полученный в результате прессовки

\*\*

Battiscopa ottenuto da taglio del fondo  
Skirting cut from plain tile  
Aus Grundfliese geschnittener Sockel  
Plinthe obtenue par découpe du fond  
Rodapié obtenido mediante corte del fondo  
Плинтус, полученный методом нарезания фоновой плитки



Vedi Appendice pag. 585  
See Appendix page 585  
Siehe Anhang S. 585  
Voir Annexe page 585  
Véase la pág. 585 del Apéndice  
Смотри приложение на стр. 585

## pezzi speciali / trims / spezialteile / pièces spéciales / piezas especiales / специальные изделия

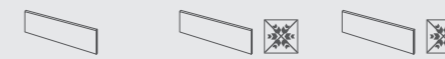

BT.B.C. \*\* 7x60  
BT.B.C.\* 8x33,3  
BT.B.C.\* 8x45

Casablanca BG	R3LN	R53X	R3LG
Casablanca CR	R3LP	R53Y	R3LH
Casablanca MA	R3LQ	R53Z	R3LJ
Casablanca GR	R3LR	R544	R3LK
Casablanca AN	R3LS	R548	R3LL
Casablanca NE	R3LT	R549	R3LM

## imballi / packaging / verpackungen / emballages / embalajes / упаковки

Scatole / Box / Karton / Boite / Caja / Коробки  
Pallet / Pallet / Palette / Palette / Pallet / Поддон



		M <sup>2</sup>	KG		M <sup>2</sup>	KG	± mm
<b>fondi / plain tiles / grundfliesen / fonds / fondos / фоновая плитка</b>							
60x60	3	1,08	23,00	40	43,20	920,00	9
30x60	6	1,08	19,55	48	51,84	938,45	9
45x45	5	1,01	19,58	33	33,41	646,27	9
33,3x33,3	16	1,77	29,71	38	67,42	1129,14	8
<b>pezzi speciali / trims / spezialteile / pièces spéciales / piezas especiales / специальные изделия</b>							
7x60	BT.B.C.	16	9,60 ml	16,32			9
8x33,3	BT.B.C.	50	16,65 ml	19,59			8,3
8x45	BT.B.C.	30	13,50 ml	18,54			9

# Life

45x45 33,3x33,3



strutturato

Gruppo Bia UNI EN 14411\_G

gres porcellanato / porcelain stoneware / feinsteinzeug / grès cérame émaillé / gres porcelánico / керамогранит

superfici / surfaces / finitions / oberflächen / superficies / поверхности:  
naturale/matt + outdoor



G

**R3FT** Life GR  
**R3K7** Life GR strutturato  
45x45

**ROA0** Life GR  
33,3x33,3



G

**R3FU** Life AN  
**R3K8** Life AN strutturato  
45x45

**ROA2** Life AN  
33,3x33,3

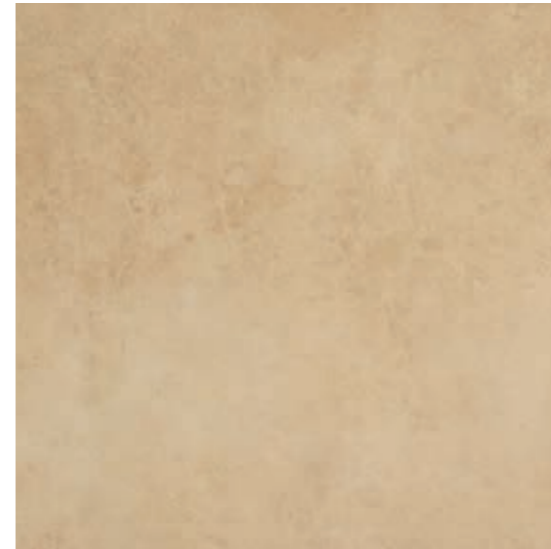

G

**R3FR** Life BG  
45x45

**ROA1** Life BG  
33,3x33,3



G

**ROA3** Life MA  
33,3x33,3



Vedi Appendice pag. 585  
See Appendix page 585  
Siehe Anhang S. 585  
Voir Annexe page 585  
Véase la pág. 585 del Apéndice  
Смотри приложение на стр. 585

Per le pavimentazioni esterne non protette, Ragno consiglia di creare una pendenza  $\geq 1,5\%$  sulla superficie calpestabile allo scopo di limitare il formarsi di ristagni d'acqua localizzati. Nel caso in cui questi ristagni permangano sulla superficie delle piastrelle nonostante una posa a regola d'arte, è necessario intervenire meccanicamente con l'utilizzo di scope o aspira-liquidi. / For unprotected outdoor pavings, Ragno recommends the creation of a gradient of  $\geq 1,5\%$  on the finished surface, to prevent the formation of patches of standing water. In the event that standing water persists on the surface of the tiles in spite of correct installation, it must be removed mechanically with the aid of brooms or wet-and-dry vacuum cleaners. / Zur Unterbindung von punktueller Stauwasserbildung bei Belägen in ungeschützten Außenbereichen, empfiehlt die Ragno die Ausbildung eines Gefälles  $\geq 1,5\%$  auf der Trittläche. Sollte trotz fachgerechter Verlegung Stauwasser auf der Fliesenoberfläche zurückbleiben, ist dessen mechanische Entfernung mit Hilfe eines Besens oder Nasssaugers erforderlich. / Pour des sols extérieurs non protégés, Ragno conseille de créer une inclinaison  $\geq 1,5\%$  sur la surface de piétinement en vue de limiter la stagnation localisée de l'eau. Si, malgré une pose dans les règles de l'art, cette stagnation devait persister à la surface des carreaux, une intervention mécanique, au moyen de balais et d'aspirateurs de liquides, est alors nécessaire. / En el caso de pavimentaciones exteriores no protegidas, Ragno recomienda crear una pendiente  $\geq 1,5\%$  en la superficie transitable para limitar la formación de depósitos localizados de agua estancada. En caso de que estos depósitos de agua permanezcan en la superficie del azulejo, aun cuando la colocación se haya realizado correctamente, será necesario intervenir mecánicamente empleando un cepillo o un aspirador de líquidos. / Для наружных незащищенных полов Ragno рекомендует создавать уклон  $\geq 1,5\%$  на пешеходной поверхности для снижения образования локальных застоев воды. В случае, если застои воды образуются на плитке несмотря на правильную укладку, необходимо прибегать к использованию механических средств, таких как щетки или же аппараты для сбора жидкостей.

## tech info

\*

Battiscopa ottenuto per pressatura / Pressed skirting tile / Gepresster Sockel / Plinthe obtenue par pressage / Rodapié obtenido mediante prensado / Плинтус, полученный в результате прессовки

pezzi speciali / trims / spezialteile / pièces spéciales / piezas especiales / специальные изделия



Life BG	R3FV	ROA5
Life MA		ROA7
Life GR	R3FX	ROA4
Life AN	R3FY	ROA6

imballi / packaging / verpackungen / emballages / embalajes / упаковки

Scatole / Box / Karton / Boîte / Caja / Коробки

Pallet / Pallet / Palette / Palette / Поддон

	M <sup>2</sup>	KG		M <sup>2</sup>	KG	± mm
--	----------------	----	--	----------------	----	------

fondi / plain tiles / grundfliesen / fonds / fondos / фоновая плитка

45x45	5	1,01	20,05	33	33,41	661,76	9
33,3x33,3	16	1,77	30,16	38	67,42	1146,03	8

pezzi speciali / trims / spezialteile / pièces spéciales / piezas especiales / специальные изделия

8x45	BT.B.C.	30	13,50 ml	21,30			9
8x33,3	BT.B.C.	50	16,65 ml	21,85			8

# Season

60x60 30x60 45x45 33,3x33,3 10x10

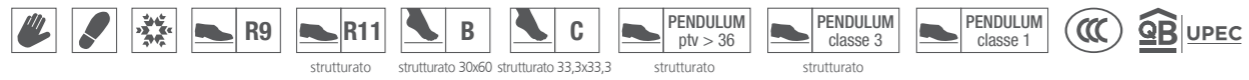

gres porcellanato - rettificato monocalibro / porcelain stoneware - rectified monocalibre / feinsteinzeug - rektifiziert, in einem werkmaß / grès cérame émaillé - rectifié monocalibre / gres porcelánico - rectificado monocalibre / керамогранит - ректифицированный монокалиберный

45x45, 33,3x33,3, 10x10, 30x60 (Outdoor)

gres porcellanato / porcelain stoneware / feinsteinzeug / grès cérame émaillé / gres porcelánico / керамогранит

superfici / surfaces / finitions / oberflächen / superficies / поверхности:  
naturale/matt + outdoor



G

**R3RN** Season White rettificato  
60x60

**R3SK** Season White  
45x45

**R3RY** Season White  
33,3x33,3



H

**R4AG** Season White\*  
10x10

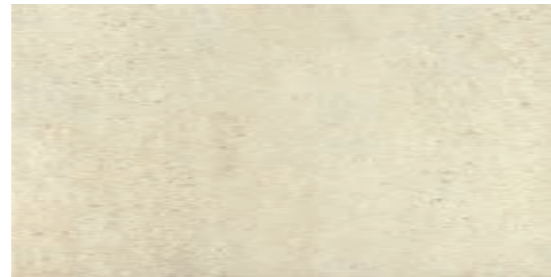

G

**R3RT** Season White rettificato  
30x60



G

**R3RP** Season Beige rettificato  
60x60

**R3SL** Season Beige  
45x45

**R3RZ** Season Beige  
33,3x33,3

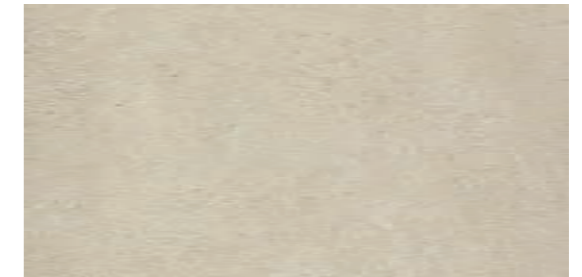

G

**R3RU** Season Beige rettificato  
30x60



G

**R3SE** Season White strutturato  
33,3x33,3



G

**R46T** Season White strutturato  
30x60



G

**R3SF** Season Beige strutturato  
33,3x33,3

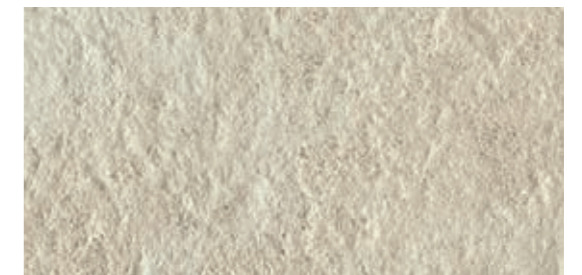

G

**R46U** Season Beige strutturato  
30x60

# Season

60x60 30x60 45x45 33,3x33,3 10x10

Gruppo Bia UNI EN 14411\_G

60x60, 30x60

gres porcellanato - rettificato monocalibro / porcelain stoneware - rectified monocaliber / feinsteinzeug - rektifiziert, in einem werkmaß / grès cérame émaillé - rectifié monocalibre / gres porcelánico - rectificado monocalibre / керамогранит - ректифицированный монокалиберный

45x45, 33,3x33,3, 10x10, 30x60 (Outdoor)

gres porcellanato / porcelain stoneware / feinsteinzeug / grès cérame émaillé / gres porcelánico / керамогранит

superfici / surfaces / finitions / oberflächen / superficies / поверхности:  
naturale/matt + outdoor



G

**R3RQ** Season Taupe rettificato  
60x60

**R3SM** Season Taupe  
45x45

**R3SA** Season Taupe  
33,3x33,3



H

**R4AJ** Season Taupe\*  
10x10



G

**R3RV** Season Taupe rettificato  
30x60



G

**R3RR** Season Grey rettificato  
60x60

**R3SN** Season Grey  
45x45

**R3SC** Season Grey  
33,3x33,3



H

**R4AK** Season Grey\*  
10x10



G

**R3RW** Season Grey rettificato  
30x60



G

**R3SG** Season Taupe strutturato  
33,3x33,3

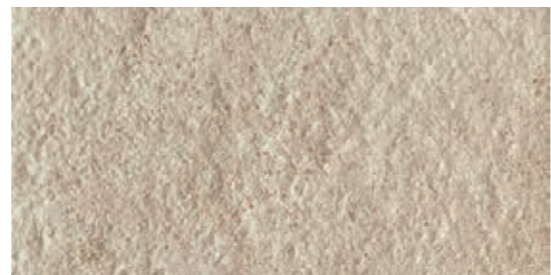

G

**R46V** Season Taupe strutturato  
30x60



G

**R3SH** Season Grey strutturato  
33,3x33,3



G

**R46W** Season Grey strutturato  
30x60



# Season

60x60 30x60 45x45 33,3x33,3 10x10

Gruppo Bla UNI EN 14411\_G

60x60, 30x60

gres porcellanato - rettificato monocalibro / porcelain stoneware - rectified monocaliber / feinsteinzeug - rektifiziert, in einem werkmaß / grès cérame émaillé - rectifié monocalibre / gres porcelánico - rectificado monocalibre / керамогранит - ректифицированный монокалберный

45x45, 33,3x33,3, 10x10, 30x60 (Outdoor)

gres porcellanato / porcelain stoneware / feinsteinzeug / grès cérame émaillé / gres porcelánico / керамогранит

superfici / surfaces / finitions / oberflächen / superficies / поверхности:  
naturale/matt + outdoor



F

**R3R5** Season Anthracite rettificato  
60x60

**R3SP** Season Anthracite  
45x45

**R3SD** Season Anthracite  
33,3x33,3



H

**R4AL** Season Anthracite\*  
10x10



F

**R3RX** Season Anthracite rettificato  
30x60

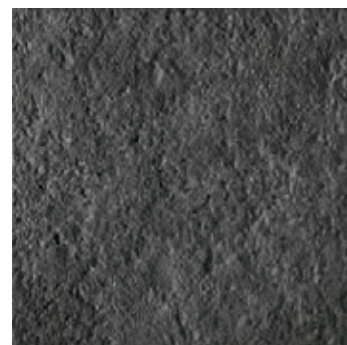

G

**R3SJ** Season Anthracite strutturato  
33,3x33,3

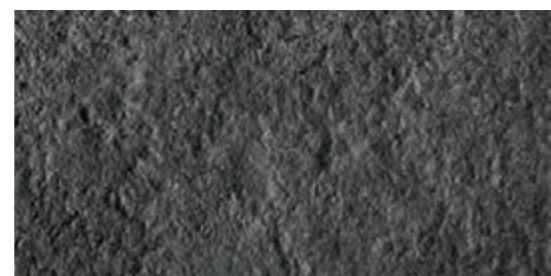

G

**R46X** Season Anthracite strutturato  
30x60

## tech info



\*  
Punto colla  
Glue-dot

\*\*

Battiscopa ottenuto da taglio del fondo  
Skirting cut from plain tile  
Aus Grundfliese geschnittener Sockel  
Plinthe obtenue par découpe du fond  
Rodapié obtenido mediante corte del fondo  
Плинтус, полученный методом нарезания фоновой плитки

\*\*\*

Battiscopa ottenuto per pressatura  
Pressed skirting tile  
Gepresster Sockel  
Plinthe obtenue par pressage  
Rodapié obtenido mediante prensado  
Плинтус, полученный в результате прессовки

\*\*\*\*

Assemblato (pag. 592)  
Two-piece L-tile (page 592)  
Randstein zweiteilig (S. 592)  
Assemblé (page 592)  
Montado (pág. 592)  
Собранная (стр. 592)



Vedi Appendice pag. 585  
See Appendix page 585  
Siehe Anhang S. 585  
Voir Annexe page 585  
Véase la pág. 585 del Apéndice  
Смотри приложение на стр. 585

pezzi speciali / trims / spezialteile / pièces spéciales / piezas especiales / специальные изделия



BT.B.C.\*\*  
7x60



BT.B.C.\*\*  
8x45



BT.B.C.\*\*\*  
8x33,3

	R3SQ	R3TA	R3SV
Season White	R3SQ	R3TA	R3SV
Season Beige	R3SR	R3TC	R3SW
Season Taupe	R3SS	R3TD	R3SX
Season Grey	R3ST	R3TE	R3SY
Season Anthracite	R3SU	R3TF	R3SZ



E. ELLE\*\*\*\*  
15x33,3

	R3TG	R3TH	R3TJ	R3TK	R3TL
Season White	R3TG	R3TH	R3TJ	R3TK	R3TL
Season Beige	R3TG	R3TH	R3TJ	R3TK	R3TL
Season Taupe	R3TG	R3TH	R3TJ	R3TK	R3TL
Season Grey	R3TG	R3TH	R3TJ	R3TK	R3TL
Season Anthracite	R3TG	R3TH	R3TJ	R3TK	R3TL

imballi / packaging / verpackungen / emballages / embalajes / упаковки

Scatole / Box / Karton /  
Boite / Caja / Коробки

Pallet / Pallet / Palette /  
Palette / Pallet / Поддон



fondi / plain tiles / grundfliesen / fonds / fondos / фоновая плитка						
60x60	3	1,08	22,50	40	43,20	900,00 9,5
30x60	6	1,08	23,04	48	51,84	1105,80 9,5
30x60 strutturato	5	0,90	19,20	48	43,20	921,60 9,5
45x45	5	1,01	19,70	33	33,41	650,11 9
33,3x33,3	16	1,77	29,59	38	67,42	1124,44 8
33,3x33,3 strutturato	16	1,77	29,59	38	67,42	1124,44 8
10x10	96	1,00	14,45	66	66,02	953,40 7

pezzi speciali / trims / spezialteile / pièces spéciales / piezas especiales / специальные изделия					
7x60 BT.B.C.	15	9 ml	14,53		9,5
8x45 BT.B.C.	30	13,50 ml	18,07		9
8x33,3 BT.B.C.	50	16,65 ml	22,10		8
15x33,3 E. ELLE	6	0,30	7,40		

Per le pavimentazioni esterne non protette, Ragno consiglia di creare una pendenza  $\geq 1,5\%$  sulla superficie calpestabile allo scopo di limitare il formarsi di ristagni d'acqua localizzati. Nel caso in cui questi ristagni permangano sulla superficie delle piastrelle nonostante una posa a regola d'arte, è necessario intervenire meccanicamente con l'utilizzo di scope o aspira-liquidi. / For unprotected outdoor pavings, Ragno recommends the creation of a gradient of  $\geq 1.5\%$  on the finished surface, to prevent the formation of patches of standing water. In the event that standing water persists on the surface of the tiles in spite of correct installation, it must be removed mechanically with the aid of brooms or wet-and-dry vacuum cleaners. / Zur Unterbindung von punktueller Stauwasserbildung bei Belägen in ungeschützten Außenbereichen, empfiehlt die Ragno die Ausbildung eines Gefälles  $\geq 1,5\%$  auf der Trittläche. Sollte trotz fachgerechter Verlegung Stauwasser auf der Fliesenoberfläche zurückbleiben, ist dessen mechanische Entfernung mit Hilfe eines Besens oder Nasssaugers erforderlich. / Pour des sols extérieurs non protégés, Ragno conseille de créer une inclinaison  $\geq 1,5\%$  sur la surface de piétinement en vue de limiter la stagnation localisée de l'eau. Si, malgré une pose dans les règles de l'art, cette stagnation devait persister à la surface des carreaux, une intervention mécanique, au moyen de balais et d'aspirateurs de liquides, est alors nécessaire. / En el caso de pavimentaciones exteriores no protegidas, Ragno recomienda crear una pendiente  $\geq 1,5\%$  en la superficie transitable para limitar la formación de depósitos localizados de agua estancada. En caso de que estos depósitos de agua permanezcan en la superficie del azulejo, aun cuando la colocación se haya realizado correctamente, será necesario intervenir mecánicamente empleando un cepillo o un aspirador de líquidos. / Для наружных незащищенных полов Ragno рекомендует создавать уклон  $\geq 1,5\%$  на пешеходной поверхности для снижения образования локальных застоев воды. В случае, если застои воды образуются на плитке несмотря на правильную укладку, необходимо прибегать к использованию механических средств, таких как щетки или же аппараты для сбора жидкостей.

# Sound

60x60 30x60 45x45 33,3x33,3



G

**R49H** Sound Off White  
60x60

**R52U** Sound Off White  
45x45

**R52K** Sound Off White  
33,3x33,3



G

**R49J** Sound Cream  
60x60

**R52V** Sound Cream  
45x45

**R52L** Sound Cream  
33,3x33,3



G

**R49K** Sound Pearl  
60x60

**R52W** Sound Pearl  
45x45

**R52M** Sound Pearl  
33,3x33,3



G

**R49L** Sound Smoke  
60x60

**R52X** Sound Smoke  
45x45

**R52N** Sound Smoke  
33,3x33,3



G

**R49M** Sound Off White  
30x60

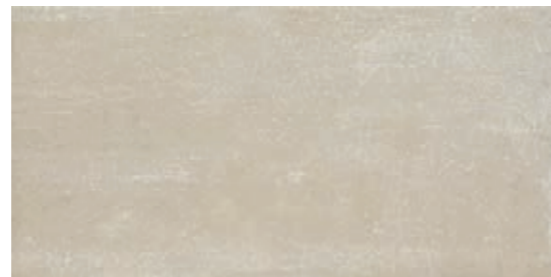

G

**R49N** Sound Cream  
30x60



G

**R49P** Sound Pearl  
30x60



G

**R49Q** Sound Smoke  
30x60

## tech info

\*

Battiscopa ottenuto per pressatura  
Pressed skirting tile  
Gepresster Sockel  
Plinthe obtenue par pressage  
Rodapié obtenido mediante prensado  
Глинтус, полученный в результате прессовки



Vedi Appendice pag. 585  
See Appendix page 585  
Siehe Anhang S. 585  
Voir Annexe page 585  
Véase la pág. 585 del Apéndice  
Смотри приложение на стр. 585

## pezzi speciali / trims / spezialteile / pièces spéciales / piezas especiales / специальные изделия



	R49R	R53T	R52Y
Sound Off White	R49R	R53T	R52Y
Sound Cream	R49S	R53U	R52Z
Sound Pearl	R49T	R53V	R53A
Sound Smoke	R49U	R53W	R53C

## imballi / packaging / verpackungen / emballages / embalajes / упаковки

Scatole / Box / Karton / Boite / Caja / Коробки	Pallet / Pallet / Palette / Palette / Паллет	≠ mm
M <sup>2</sup>	M <sup>2</sup>	KG

fondi / plain tiles / grundfliesen / fonds / fondos / фоновая плитка						
60x60	3	1,08	24,78	40	43,20	991,50
30x60	6	1,08	20,83	48	51,84	999,80
45x45	5	1,01	21,79	33	33,41	719,13
33,3x33,3	16	1,77	30,10	38	67,42	1143,95
pezzi speciali / trims / spezialteile / pièces spéciales / piezas especiales / специальные изделия						
7x60	BT.B.C.	16	9,60 ml	15,53		8,5
8x45	BT.B.C.	30	13,50 ml	16,53		9
8x33,3	BT.B.C.	50	16,65 ml	20,60		8

# Escape

12,5x50

Gruppo Bia UNI EN 14411\_G

gres porcellanato / porcelain stoneware / feinsteinzeug / grès cérame émaillé / gres porcelánico / керамогранит

superfici / surfaces / finitions / oberflächen / superficies / поверхности:  
naturale/matt + outdoor

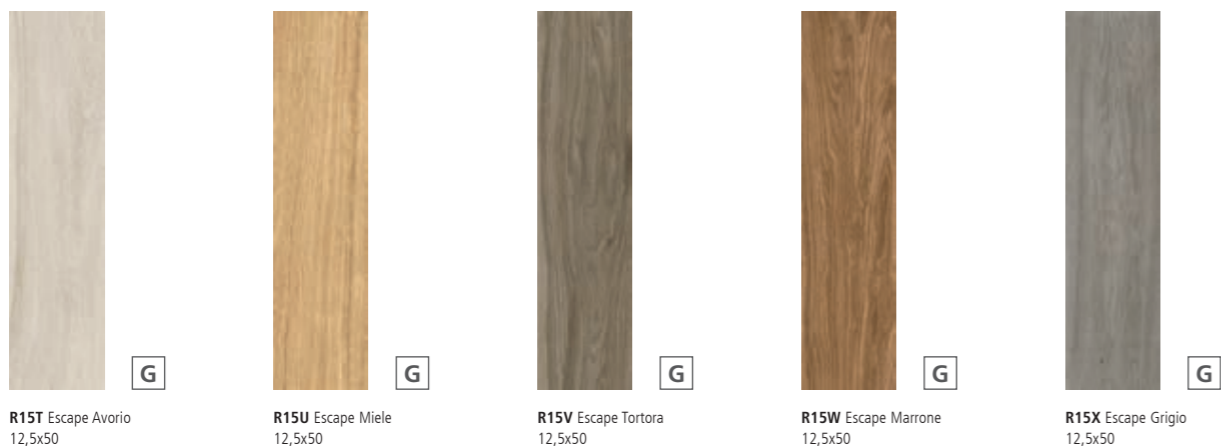

**R15T** Escape Avorio 12,5x50 **G** **R15U** Escape Miele 12,5x50 **G** **R15V** Escape Tortora 12,5x50 **G** **R15W** Escape Marrone 12,5x50 **G** **R15X** Escape Grigio 12,5x50 **G**

Abbinabile ai fondi / Matching with colours / Mit den Grundfliesen kombinierbar / Peut s'associer aux carreaux de base de couleurs / Puede combinarse con los fondos / Сочетается с фоновой плиткой:

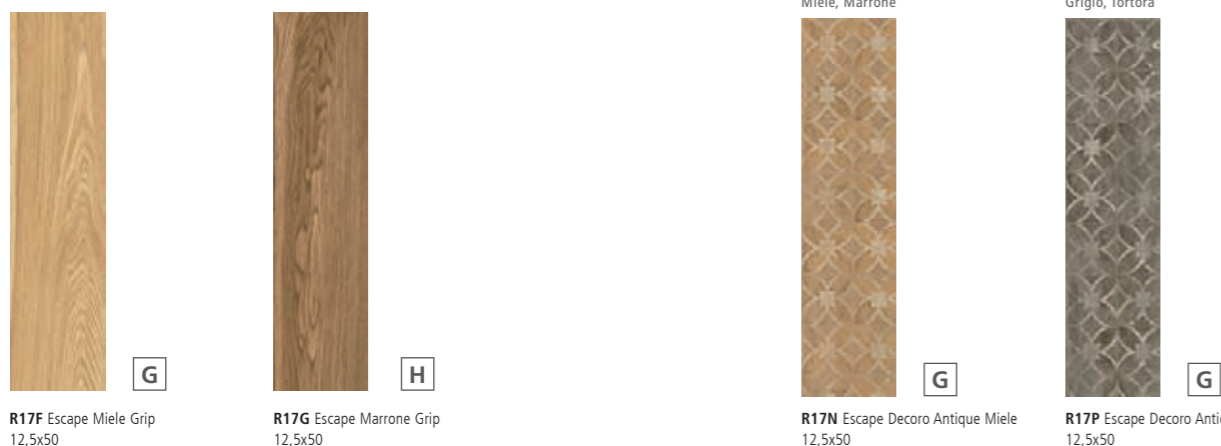

**R17F** Escape Miele Grip 12,5x50 **G** **R17G** Escape Marrone Grip 12,5x50 **H** **R17N** Escape Decoro Antique Miele 12,5x50 **G** **R17P** Escape Decoro Antique Grigio 12,5x50 **G**

## tech info

\*

Battiscopa ottenuto da taglio del fondo / Skirting cut from plain tile / Aus Grundfliese geschnittener Sockel / Plinthe obtenue par découpe du fond / Rodapié obtenido mediante corte del fondo / Плинтус, полученный методом нарезания фоновой плитки



Apprezzabili differenze nell'aspetto di superficie e grafica all'interno della stessa produzione. / Clearly distinguishable differences in texture and pattern within the same production run. / Auffällige Unterschiede in Aussehen und Struktur innerhalb der gleichen Produktionscharge. / Différences visibles au niveau de l'aspect et de la fantaisie entre les carreaux du même lot de production. / Diferencias visibles en el aspecto de la superficie y los motivos dentro de un mismo lote de producción. / Заметные отличия вида поверхности и графики в одной и той же партии.

pezzi speciali / trims / spezialteile / pièces spéciales / piezas especiales / специальные изделия



BT.B.C.\*  
6x50

Escape	Code
Escape Avorio	R16J
Escape Miele	R16K
Escape Tortora	R16L
Escape Marrone	R16M
Escape Grigio	R16N

imballi / packaging / verpackungen / emballages / embalajes / упаковки

Scatole / Box / Karton / Boîte / Caja / Коробки	Pallet / Pallet / Palette / Palette / Pallet / Поддон	mm
M <sup>2</sup>	M <sup>2</sup>	KG

fondi / plain tiles / grundfliesen / fonds / fondos / фоновая плитка	12,5x50	16	1,00	17,00	72	72,00	1224,00	8,5
12,5x50 grip	16	1,00	17,00	72	72,00	1224,00	8,5	
12,5x50 decoro	16	1,00	17,00	72	72,00	1224,00	8,5	

pezzi speciali / trims / spezialteile / pièces spéciales / piezas especiales / специальные изделия	6x50	BT.B.C.	15	7,5 ml	9,37	8,5
--	------	---------	----	--------	------	-----

# Freetime

12,5x50

Gruppo Bia UNI EN 14411\_G

gres porcellanato / porcelain stoneware / feinsteinzeug / grès cérame émaillé / gres porcelánico / керамогранит

superfici / surfaces / finitions / oberflächen / superficies / поверхности:  
naturale/matt



**R44W** Freetime Avorio 12,5x50 **G** **R44X** Freetime Miele 12,5x50 **G** **R44Y** Freetime Rovere 12,5x50 **G** **R45A** Freetime Marrone 12,5x50 **G** **R44Z** Freetime Fumo 12,5x50 **G**

## tech info

\*

Battiscopa ottenuto da taglio del fondo / Skirting cut from plain tile / Aus Grundfliese geschnittener Sockel / Plinthe obtenue par découpe du fond / Rodapié obtenido mediante corte del fondo / Плинтус, полученный методом нарезания фоновой плитки

pezzi speciali / trims / spezialteile / pièces spéciales / piezas especiales / специальные изделия



BT.B.C.\*  
6x50

Freetime	Code
Freetime Avorio	R45C
Freetime Miele	R45D
Freetime Rovere	R45E
Freetime Marrone	R45G
Freetime Fumo	R45F

imballi / packaging / verpackungen / emballages / embalajes / упаковки

Scatole / Box / Karton / Boîte / Caja / Коробки	Pallet / Pallet / Palette / Palette / Pallet / Поддон	mm
M <sup>2</sup>	M <sup>2</sup>	KG

fondi / plain tiles / grundfliesen / fonds / fondos / фоновая плитка	12,5x50	16	1,00	17,00	72	72,00	1224,00	8,5
--	---------	----	------	-------	----	-------	---------	-----

pezzi speciali / trims / spezialteile / pièces spéciales / piezas especiales / специальные изделия	6x50	BT.B.C.	15	7,5 ml	9,00	8,5
--	------	---------	----	--------	------	-----

# Emilia

30x30 15x15

Gruppo Bia UNI EN 14411\_G

gres porcellanato / porcelain stoneware / feinsteinzeug / grès cérame émaillé / gres porcelánico / керамогранит

superfici / surfaces / finitions / oberflächen / superficies / поверхности:  
naturale/matt



4X74 Emilia BI  
30x30



R5L3 Emilia BG  
30x30



R5L2 Emilia RO  
30x30

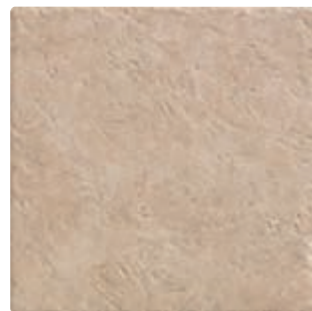

4X75 Emilia SA  
30x30

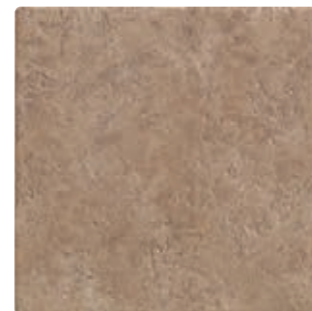

4X78 Emilia NO  
30x30



4X77 Emilia CT  
30x30



RL14 Emilia GR  
30x30



4X09 Emilia BI  
15x15



0L38 Emilia BG  
15x15

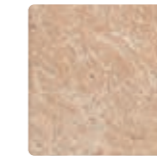

0L37 Emilia RO  
15x15



4X10 Emilia SA  
15x15

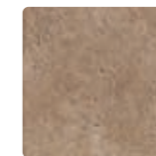

4X11 Emilia NO  
15x15



0L40 Emilia CT  
15x15



0L36 Emilia GR  
15x15



## tech info

\*

Battiscopa ottenuto per pressatura  
Pressed skirting tile  
Gepresster Sockel  
Plinthe obtenue par pressage  
Rodapié obtenido mediante prensado  
Глинтус, полученный в результате прессовки

\*\*

Monolitico (pag. 592)  
One-piece L-tile (page 592)  
Randstein einteilig (S. 592)  
Monolithique (page 592)  
Monolítico (pág. 592)  
Монолитная (стр. 592)

pezzi speciali / trims / spezialteile / pièces spéciales / piezas especiales / специальные изделия



BT.B.C.\*  
7,5x30

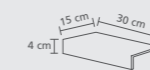

E.ELLE\*\*  
15x30

Emilia BI	ROCJ	4X12
Emilia BG	ROCK	0L65
Emilia RO	ROCL	0L64
Emilia SA	R4LR	4X13
Emilia NO	ROCN	4X14
Emilia CT	ROCP	0L67
Emilia GR	ROCQ	0L63

imballi / packaging / verpackungen / emballages / embalajes / упаковки

Scatole / Box / Karton /  
Boite / Caja / Коробки

Pallet / Pallet / Palette /  
Palette / Pallet / Поддон

	M <sup>2</sup>	KG		M <sup>2</sup>	KG	≠ mm
--	----------------	----	--	----------------	----	---------

fondi / plain tiles / grundfliesen / fonds / fondos / фоновая плитка						
30x30	14	1,26	25,12	40	50,40	1004,99
15x15	40	0,90	15,25	64	57,60	976,27

pezzi speciali / trims / spezialteile / pièces spéciales / piezas especiales / специальные изделия						
15x30	E.ELLE	6	0,27	5,70		
7,5x30	BT.B.C.	50	15,00 ml	20,05		8

# Galassia

30x30 20x20

Gruppo Bia UNI EN 14411\_G

gres fine porcellanato / fine porcelain stoneware / feinsteinzeug / grès cérame fin / gres porcelánico fino / мелкозернистый керамогранит

superfici / surfaces / finitions / oberflächen / superficies / поверхности:  
naturale/matt + outdoor

HIGH PERFORMANCE

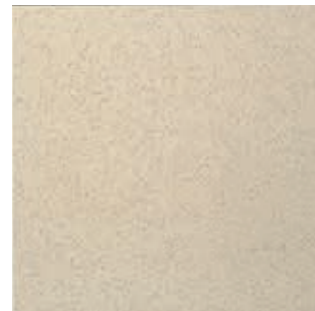
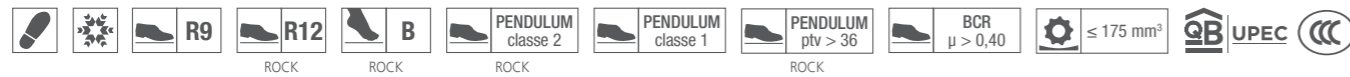

H

**4M28** Panna  
**R9Z5** Panna (≠ 14 mm)  
20x20  
**4M41** Panna  
30x30



H

**ROUT** Canapa New  
30x30

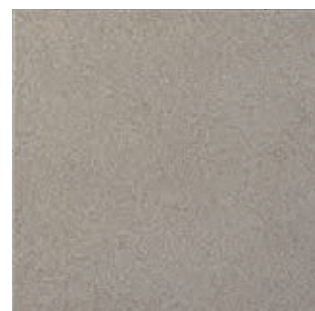

H

**4M32** Fumo  
20x20  
**4M45** Fumo  
30x30

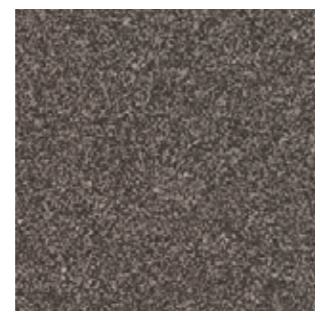

H

**ROUR** Antracite New  
30x30



H

**ROVJ** Panna ROCK  
20x20

## tech info

**\***  
Battiscopa ottenuto per pressatura  
Pressed skirting tile  
Gepresster Sockel  
Plinthe obtenue par pressage  
Rodapié obtenido mediante prensado  
Плинтус, полученный в результате прессовки

**\*\***  
Battiscopa ottenuto da taglio del fondo  
Skirting cut from plain tile  
Aus Grundfliese geschnittener Sockel  
Plinthe obtenue par découpe du fond  
Rodapié obtenido mediante corte del fondo  
Плинтус, полученный методом нарезания фоновой плитки

**\*\*\***  
Scalino becco civetta con righe in corindone (pag. 592)  
Coved step tile with carborundum strips (page 592)  
Treppenauftritt mit Halbrundstab und aufgesetzten Korundprofilen (S. 592)  
Marche à bord rond avec bandes en corindon (page 592)  
Escalón de canto romo con rayas de corindón (pág. 592)  
Ступень с закругленным краем с полосками из корунда (стр. 592)



Vedi Appendice pag. 585  
See Appendix page 585  
Siehe Anhang S. 585  
Voir Annexe page 585  
Véase la pág. 585 del Apéndice  
Смотри приложение на стр. 585

## pezzi speciali / trims / spezialteile / pièces spéciales / piezas especiales / специальные изделия

	BT.B.C.* 10x20	BT.B.C.** 9,5x30	SC.B.C.*** 30x30
Panna	RA98	ROWG	8E46
Canapa New	-	ROWL	ROYD
Fumo	-	ROWJ	7C43
Antracite New	-	ROWH	ROYA

	BT.FRANCESE* 10x20	AN.INT.BT. 3x10	SPEST.BT. 3x10
Panna	ROWR	ROWT	ROWX
Fumo	4T64	ROWU	ROWY

	BT.SGU.* 10x20	AN.INT.SGU. 3x10	SPEST.SGU. 3x10
Panna	ROXQ	ROXS	ROXW
Fumo	4P22	ROXT	ROXX

	CN. 3x20
Panna	ROXC
Fumo	ROXD

## imballi / packaging / verpackungen / emballages / embalajes / упаковки

	Scatole / Box / Karton / Boite / Caja / Коробки			Pallet / Pallet / Palette / Palette / Поддон		
	M <sup>2</sup>	KG	mm	M <sup>2</sup>	KG	mm
<b>fondi / plain tiles / grundfliesen / fonds / fondos / фоновая плитка</b>						
30x30	15	1,35	24,00	40	54,00	959,96
20x20	30	1,20	21,10	54	64,80	1139,68
20x20 14 mm	16	0,64	19,86	54	34,56	1072,95
20x20 ROCK	30	1,20	20,63	54	64,80	1113,86

	<b>pezzi speciali / trims / spezialteile / pièces spéciales / piezas especiales / специальные изделия</b>					
30x30	SC.B.C.	15	1,35	26,27		
10x20	BT.	25	5,00 ml	9,90		8
9,5x30	BT.B.C.	30	9,00 ml	16,29		8,5
3x10	AN./SP.	10	0,03	1,63		
3x20	CN.	10	0,06	1,18		

Per le pavimentazioni esterne non protette, Ragno consiglia di creare una pendenza  $\geq 1,5\%$  sulla superficie calpestabile allo scopo di limitare il formarsi di ristagni d'acqua localizzati. Nel caso in cui questi ristagni permangano sulla superficie delle piastrelle nonostante una posa a regola d'arte, è necessario intervenire meccanicamente con l'utilizzo di scope o aspira-liquidi. / For unprotected outdoor pavings, Ragno recommends the creation of a gradient of  $\geq 1.5\%$  on the finished surface, to prevent the formation of patches of standing water. In the event that standing water persists on the surface of the tiles in spite of correct installation, it must be removed mechanically with the aid of brooms or wet-and-dry vacuum cleaners. / Zur Unterbindung von punktueller Stauwasserbildung bei Belägen in ungeschützten Außenbereichen, empfiehlt die Ragno die Ausbildung eines Gefälles  $\geq 1,5\%$  auf der Trittläche. Sollte trotz fachgerechter Verlegung Stauwasser auf der Fliesenoberfläche zurückbleiben, ist dessen mechanische Entfernung mit Hilfe eines Besens oder Nasssaugers erforderlich. / Pour des sols extérieurs non protégés, Ragno conseille de créer une inclinaison  $\geq 1,5\%$  sur la surface de piétinement en vue de limiter la stagnation localisée de l'eau. Si, malgré une pose dans les règles de l'art, cette stagnation devait persister à la surface des carreaux, une intervention mécanique, au moyen de balais et d'aspirateurs de liquides, est alors nécessaire. / En el caso de pavimentaciones exteriores no protegidas, Ragno recomienda crear una pendiente  $\geq 1,5\%$  en la superficie transitable para limitar la formación de depósitos localizados de agua estancada. En caso de que estos depósitos de agua permanezcan en la superficie del azulejo, aun cuando la colocación se haya realizado correctamente, será necesario intervenir mecánicamente empleando un cepillo o un aspirador de líquidos. / Для наружных незащищенных полов Ragno рекомендует создавать уклон  $\geq 1,5\%$  на пешеходной поверхности для снижения образования локальных застоев воды. В случае, если застои воды образуются на плитке несмотря на правильную укладку, необходимо прибегать к использованию механических средств, таких как щетки или же аппараты для сбора жидкостей.



*Home Line*  
**WALL**

*Rivestimenti*  
*Wall tiles*  
*Wandfliesen*  
*Revêtements*  
*Revestimientos*  
*Настенная плитка*

# Candy

20x50



**R15P** Candy Puro  
20x50



**RG4M** Candy Puro Struttura Brezza 3D  
20x50



**R15Q** Candy Ecrù  
20x50



**RG4K** Candy Ecrù Struttura Brezza 3D  
20x50



**R15N** Candy Cenere  
20x50



**RG4N** Candy Cenere Struttura Brezza 3D  
20x50



**R15R** Candy Mostarda  
20x50



**RG4P** Candy Mostarda Struttura Brezza 3D  
20x50



**R15M** Candy Oceano  
20x50

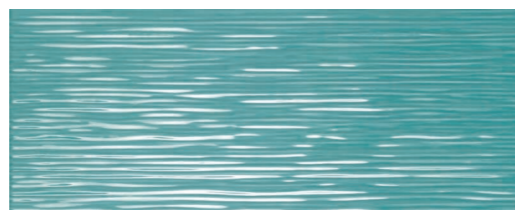

**RG4R** Candy Oceano Struttura Brezza 3D  
20x50



**R15S** Candy Granata  
20x50

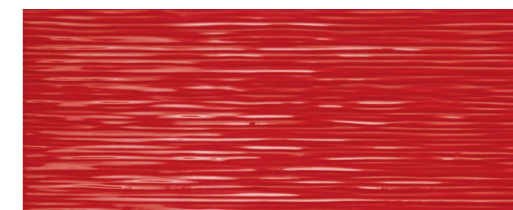

**RG4Q** Candy Granata Struttura Brezza 3D  
20x50



**R15L** Candy Oltremare  
20x50

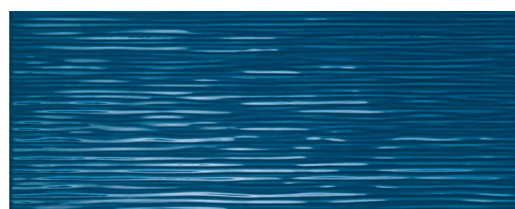

**RG4L** Candy Oltremare Struttura Brezza 3D  
20x50

# Candy

20x50

Abbinabile ai fondi / Matching with colours / Mit den Grundfliesen kombinierbar / Peut s'associer aux carreaux de base de couleurs / Puede combinarse con los fondos / Сочетается с фоновой плиткой:

Ecrù, Mostarda, Oltremare



**R6GU** Candy Decoro Motivo Ecrù  
20x50

Abbinabile ai fondi / Matching with colours / Mit den Grundfliesen kombinierbar / Peut s'associer aux carreaux de base de couleurs / Puede combinarse con los fondos / Сочетается с фоновой плиткой:

Puro, Oceano, Oltremare



**R189** Candy Decoro Motivo Puro  
20x50

Abbinabile ai fondi / Matching with colours / Mit den Grundfliesen kombinierbar / Peut s'associer aux carreaux de base de couleurs / Puede combinarse con los fondos / Сочетается с фоновой плиткой:

Puro, Granata

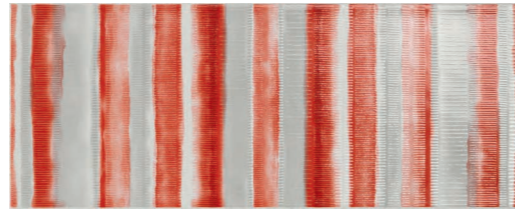

**RFGH** Candy Decoro Riviera Granata  
20x50

Abbinabile ai fondi / Matching with colours / Mit den Grundfliesen kombinierbar / Peut s'associer aux carreaux de base de couleurs / Puede combinarse con los fondos / Сочетается с фоновой плиткой:

Ecrù, Mostarda, Puro

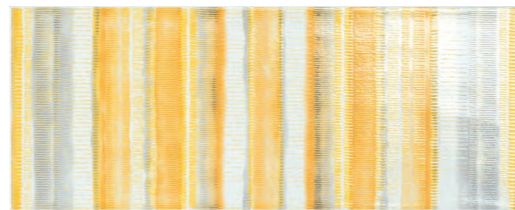

**RFGG** Candy Decoro Riviera Ecrù  
20x50

Abbinabile ai fondi / Matching with colours / Mit den Grundfliesen kombinierbar / Peut s'associer aux carreaux de base de couleurs / Puede combinarse con los fondos / Сочетается с фоновой плиткой:

Puro, Oceano, Oltremare

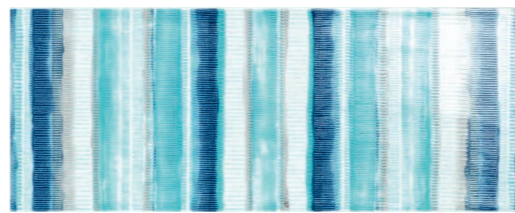

**RFGF** Candy Decoro Riviera Oceano  
20x50

# Creek

20x50



Gruppo Bili UNI EN 14411\_L

rivestimenti in pasta bianca / white body wall tiles / wandfliesen aus weissen ton scherben / revetements en pate blanche / revestimientos en pasta blanca / облицовка из белой глины

superfici / surfaces / finitions / oberflächen / superficies / поверхности: **matt**



**R3RE** Creek Bianco  
20x50



**R3RL** Creek Bianco Struttura Vento 3D  
20x50

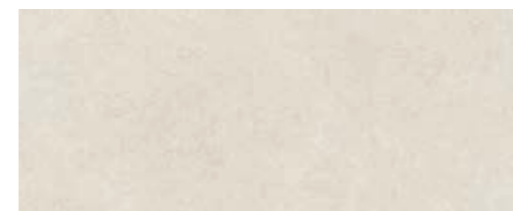

**R3RF** Creek Avorio  
20x50



**R3WE** Creek Avorio Struttura Vento 3D  
20x50

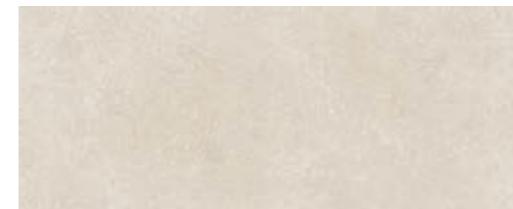

**R3RH** Creek Beige  
20x50



**R3WF** Creek Beige Struttura Vento 3D  
20x50



**R3RG** Creek Grigio  
20x50

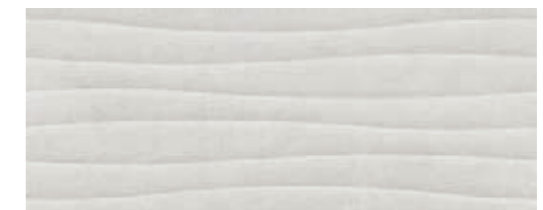

**R3RM** Creek Grigio Struttura Vento 3D  
20x50

imballi / packaging / verpackungen / emballages / embalajes / упаковки

Scatole / Box / Karton / Boite / Caja / Коробки Pallet / Pallet / Palette / Palette / Pallet / Поддон



fondi / plain tiles / grundfliesen / fonds / fondos / фоновая плитка	14	1,40	21,05	48	67,20	1010,47	8,5
20x50	14	1,40	21,05	48	67,20	1010,47	8,5
20x50 struttura brezza 3D	14	1,40	21,05	48	67,20	1010,47	8,5
decori / decorative pieces / dekore / décors / decoraciones / декоры							
20x50 decoro motivo	14	1,40	21,05	48	67,20	1010,47	8,5
20x50 decoro riviera	4	6,40	6,11				8,5



# Creek

20x50

Abbinabile ai fondi / Matching with colours / Mit den Grundfliesen kombinierbar / Peut s'associer aux carreaux de base de couleurs / Puede combinarse con los fondos / Сочетается с фоновой плиткой:

Grigio, Bianco



**R3RK** Creek Mosaico Grigio  
20x50

Abbinabile ai fondi / Matching with colours / Mit den Grundfliesen kombinierbar / Peut s'associer aux carreaux de base de couleurs / Puede combinarse con los fondos / Сочетается с фоновой плиткой:

Avorio, Beige

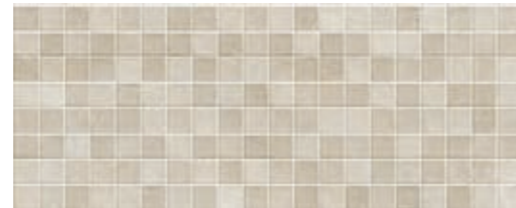

**R3RJ** Creek Mosaico Beige  
20x50

Abbinabile ai fondi / Matching with colours / Mit den Grundfliesen kombinierbar / Peut s'associer aux carreaux de base de couleurs / Puede combinarse con los fondos / Сочетается с фоновой плиткой:

Grigio, Bianco



**R5HW** Creek Decoro Accordi Bianco  
20x50

Abbinabile ai fondi / Matching with colours / Mit den Grundfliesen kombinierbar / Peut s'associer aux carreaux de base de couleurs / Puede combinarse con los fondos / Сочетается с фоновой плиткой:

Avorio, Beige



**R5HX** Creek Decoro Accordi Avorio  
20x50



**R5QP** Creek Decoro Raso Bianco\*  
20x50



**R5QQ** Creek Decoro Raso Avorio\*  
20x50

60x120 60x60 45x45 30x60

Gruppo Bla UNI EN 14411\_G

pavimenti coordinati / coordinated floor tiles / koordinierte bodenfliesen / sols coordonnes / pavimentos coordinados / координированные полы

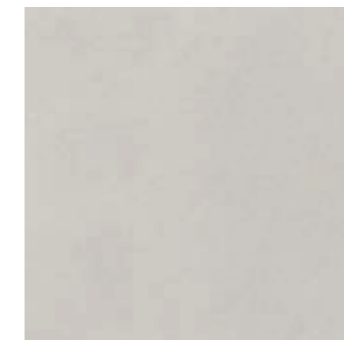

H

**R5K0** Creek Bianco rettificato  
60x120

**R4EF** Creek Bianco rettificato  
60x60

**R5J4** Creek Bianco rettificato  
45x45

**R4HM** Creek Bianco rettificato

**R4NP** Creek Bianco strutturato rettificato  
30x60



H

**R5JZ** Creek Grigio rettificato  
60x120

**R4EE** Creek Grigio rettificato  
60x60

**R5J3** Creek Grigio rettificato  
45x45

**R4HL** Creek Grigio rettificato

**R4NN** Creek Grigio strutturato rettificato  
30x60



H

**R5JY** Creek Antracite rettificato  
60x120

**R4ED** Creek Antracite rettificato  
60x60

**R5J2** Creek Antracite rettificato  
45x45

**R4HK** Creek Antracite rettificato

**R4NM** Creek Antracite strutturato rettificato  
30x60

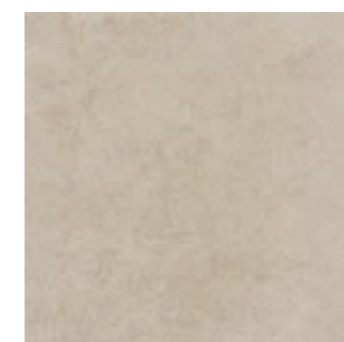

H

**R5K1** Creek Avorio rettificato  
60x120

**R4EG** Creek Avorio rettificato  
60x60

**R5J5** Creek Avorio rettificato  
45x45

**R4HN** Creek Avorio rettificato

**R4NQ** Creek Avorio strutturato rettificato  
30x60

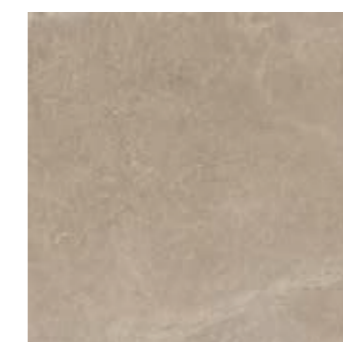

H

**R5K2** Creek Beige rettificato  
60x120

**R4EH** Creek Beige rettificato  
60x60

**R5J6** Creek Beige rettificato  
45x45

**R4KX** Creek Beige rettificato

**R4NR** Creek Beige strutturato rettificato  
30x60

## tech info

★

Decoro con lustri/metalli preziosi utilizzabile a rivestimento; si consiglia la pulizia con detersivi neutri, non abrasivi. È sconsigliata la posa nell'area doccia. / Decors with lustres/precious metals used for covering; we recommend cleaning with neutral, non-abrasive detergents. Tiles should not be installed in the shower area. / Dekor mit Glanzelementen/Edelmetallen für die Wandverkleidung; es wird die Reinigung mit neutralen, scheuermittelfreien Reinigungsmitteln empfohlen. Die Verlegung in der Duschnische wird nicht empfohlen. / Décor avec lustres/métaux précieux à poser sur le mur. Lavage recommandé avec des détergents neutres, non abrasifs. Pose déconseillée dans la douche. / Decoración con elementos brillantes/metales preciosos utilizable para revestir superficies; se recomienda limpiarla con detergentes neutros, no abrasivos. Se desaconseja colocarla en el área de la ducha. / Декор с блестящим покрытием/драгоценными металлами, используемый для облицовки; рекомендуется чистка с использованием нейтральных, неабразивных моющих средств. Не рекомендуется укладка в душевой зоне.



Mosaico preinciso da stuccare  
Pre-cut mosaic, requires grouting  
Mit Fugen zu verlegendes, vorgeschchnittenes Mosaik  
Mosaïque pré-coupée à jointoyer  
Mosaico preinciso para rejuntar  
Мозаика с насечкой для затирки

imballi / packaging / verpackungen / emballages / embalajes / упаковки

Scatole / Box / Karton /  
Boîte / Caja / Коробки

Pallet / Pallet / Palette /  
Palette / Pallet / Поддон



fondi / plain tiles / grundfliesen / fonds / fondos / фоновая плитка	20x50	fondo / struttura 3D	14	1,40	20,90	48	67,20	1003,20	8,5
decori / decorative pieces / dekore / décors / decoraciones / декоры	20x50	mosaico	14	1,40	20,90	48	67,20	1003,20	8,5
	20x50	decoro Accordi	14	1,40	20,16	48	67,20	967,68	8,5
	20x50	decoro Raso	4	0,40	6,11				8,5

# Grace

20x50



rivestimenti in pasta bianca / white bodywall tiles / wandfliesen aus weissen ton scherben / revetements en pate blanche / revestimientos en pasta blanca / облицовка из белой глины

superfici / surfaces / finitions / oberflächen / superficies / поверхности:  
glossy



**R4CT** Grace Bianco  
20x50



**R4CU** Grace Beige  
20x50



**R4CV** Grace Grigio SC.  
20x50



**R4CW** Grace Beige SC.  
20x50

Abbinabile ai fondi / Matching with colours / Mit den Grundfliesen kombinierbar / Peut s'associer aux carreaux de base de couleurs / Puede combinarse con los fondos / Сочетается с фоновой плиткой:

Bianco, Grigio SC.



**R4DJ** Grace Mosaico Bianco  
20x50

Abbinabile ai fondi / Matching with colours / Mit den Grundfliesen kombinierbar / Peut s'associer aux carreaux de base de couleurs / Puede combinarse con los fondos / Сочетается с фоновой плиткой:

Beige, Beige SC.



**R4DK** Grace Mosaico Beige  
20x50

Abbinabile ai fondi / Matching with colours / Mit den Grundfliesen kombinierbar / Peut s'associer aux carreaux de base de couleurs / Puede combinarse con los fondos / Сочетается с фоновой плиткой:

Bianco, Grigio SC.



**R4GC** Grace Decoro Bianco\*  
20x50

Abbinabile ai fondi / Matching with colours / Mit den Grundfliesen kombinierbar / Peut s'associer aux carreaux de base de couleurs / Puede combinarse con los fondos / Сочетается с фоновой плиткой:

Beige, Beige SC.



**R4GD** Grace Decoro Beige\*  
20x50

Abbinabile ai fondi / Matching with colours / Mit den Grundfliesen kombinierbar / Peut s'associer aux carreaux de base de couleurs / Puede combinarse con los fondos / Сочетается с фоновой плиткой:

Bianco, Grigio SC.



**R4GE** Grace Decoro Bianco\*  
20x50

Abbinabile ai fondi / Matching with colours / Mit den Grundfliesen kombinierbar / Peut s'associer aux carreaux de base de couleurs / Puede combinarse con los fondos / Сочетается с фоновой плиткой:

Beige, Beige SC.



**R4GF** Grace Decoro Beige\*  
20x50

Abbinabile ai fondi / Matching with colours / Mit den Grundfliesen kombinierbar / Peut s'associer aux carreaux de base de couleurs / Puede combinarse con los fondos / Сочетается с фоновой плиткой:

Bianco, Grigio SC.



**R4GG** Grace Decoro Bianco\*  
20x50

Abbinabile ai fondi / Matching with colours / Mit den Grundfliesen kombinierbar / Peut s'associer aux carreaux de base de couleurs / Puede combinarse con los fondos / Сочетается с фоновой плиткой:

Beige, Beige SC.



**R4GH** Grace Decoro Beige\*  
20x50

## tech info

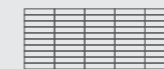

Mosaico preinciso da stuccare  
Pre-cut mosaic, requires grouting  
Mit Fugen zu verlegendes, vorgeschchnittenes Mosaik  
Mosaïque pré-coupée à jointoyer  
Mosaico preinciso para rejuntar  
Мозаика с насечкой для затирки

\*

Decoro con lustrimetalli preziosi utilizzabile a rivestimento; si consiglia la pulizia con detersivi neutri, non abrasivi. È sconsigliata la posa nell'area doccia. / Decors with lustres/precious metals used for covering; we recommend cleaning with neutral, non-abrasive detergents. Tiles should not be installed in the shower area. / Dekor mit Glanzelementen/Edelmetallen für die Wandverkleidung; es wird die Reinigung mit neutralen, scheuermittelfreien Reinigungsmitteln empfohlen. Die Verlegung in der Duschnische wird nicht empfohlen. / Décor avec lustres/métaux précieux à poser sur le mur. Lavage recommandé avec des détergents neutres, non abrasifs. Pose déconseillée dans la douche. / Decoración con elementos brillantes/metales preciosos utilizable para revestir superficies; se recomienda limpiarla con detergentes neutros, no abrasivos. Se desaconseja colocarla en el área de la ducha. / Декор с блестящим покрытием/драгоценными металлами, используемый для облицовки; рекомендуется чистка с использованием нейтральных, неабразивных моющих средств. Не рекомендуется укладка в душевой зоне.

imballi / packaging / verpackungen / emballages / embalajes / упаковки

Scatole / Box / Karton / Boîte / Caja / Коробки Pallet / Pallet / Palette / Palette / Pallet / Поддон



fondi / plain tiles / grundfliesen / fonds / fondos / фоновая плитка						
20x50	rivestimento	14	1,40	21,05	48	67,20 1010,47 8,5
20x50	mosaico	14	1,40	21,05	48	67,20 1010,47 8,5
decori / decorative pieces / dekore / décors / decoraciones / декоры						
20x50		4	0,40	6,15		

# Land

20x50



**R4CY** Land Ivory  
20x50



**R4CZ** Land Sand  
20x50



**R4DA** Land Red  
20x50

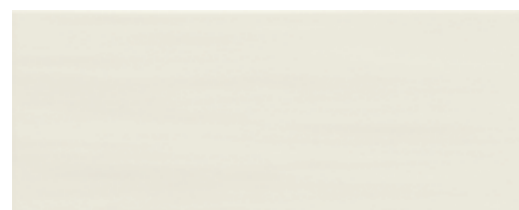

**R4CX** Land White  
20x50



**R4JV** Land Grey  
20x50



**R4DC** Land Blue  
20x50



**R4DE** Land Mosaico Ivory  
20x50

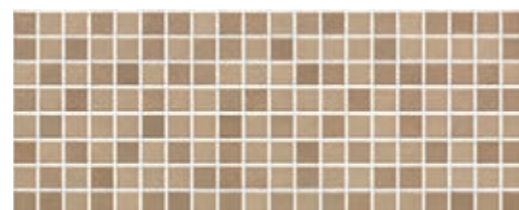

**R4DF** Land Mosaico Sand  
20x50

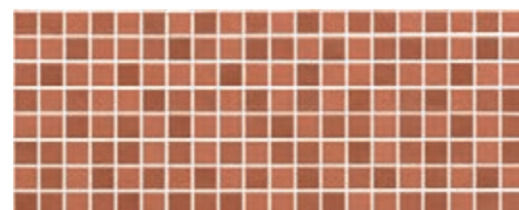

**R4DG** Land Mosaico Red  
20x50



**R4DD** Land Mosaico White  
20x50

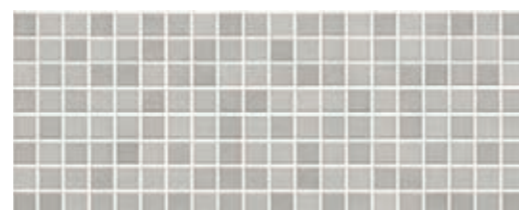

**R4JW** Land Mosaico Grey  
20x50

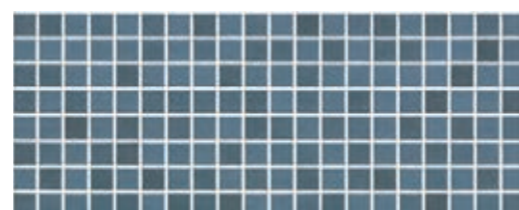

**R4DH** Land Mosaico Blue  
20x50

Abbinabile ai fondi / Matching with colours / Mit den Grundfliesen kombinierbar / Peut s'associer aux carreaux de base de couleurs / Puede combinarse con los fondos / Сочетается с фоновой плиткой:

Ivory, Sand



**R4HZ** Land Decoro Ivory  
20x50

Abbinabile ai fondi / Matching with colours / Mit den Grundfliesen kombinierbar / Peut s'associer aux carreaux de base de couleurs / Puede combinarse con los fondos / Сочетается с фоновой плиткой:

Ivory, Sand



**R4JC** Land Decoro Righe Ivory\*  
20x50

Abbinabile ai fondi / Matching with colours / Mit den Grundfliesen kombinierbar / Peut s'associer aux carreaux de base de couleurs / Puede combinarse con los fondos / Сочетается с фоновой плиткой:

Ivory, Sand



**R4JE** Land Decoro Ivory\*\*  
20x50

Abbinabile ai fondi / Matching with colours / Mit den Grundfliesen kombinierbar / Peut s'associer aux carreaux de base de couleurs / Puede combinarse con los fondos / Сочетается с фоновой плиткой:

White, Grey, Blue



**R4JA** Land Decoro White  
20x50

Abbinabile ai fondi / Matching with colours / Mit den Grundfliesen kombinierbar / Peut s'associer aux carreaux de base de couleurs / Puede combinarse con los fondos / Сочетается с фоновой плиткой:

White, Grey, Blue



**R4JD** Land Decoro Righe Grey\*  
20x50

Abbinabile ai fondi / Matching with colours / Mit den Grundfliesen kombinierbar / Peut s'associer aux carreaux de base de couleurs / Puede combinarse con los fondos / Сочетается с фоновой плиткой:

White, Grey, Blue

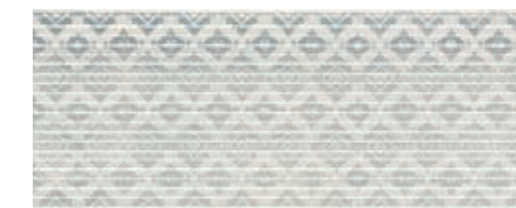

**R4LS** Land Decoro Grey\*\*  
20x50

## tech info

\*

Decoro con lustri/metalli preziosi utilizzabile a rivestimento; si consiglia la pulizia con detersivi neutri, non abrasivi. È sconsigliata la posa nell'area doccia. / Decors with lustres/precious metals used for covering; we recommend cleaning with neutral, non-abrasive detergents. Tiles should not be installed in the shower area. / Dekor mit Glanzelementen/Edelmetallen für die Wandverkleidung; es wird die Reinigung mit neutralen, scheuermittelfreien Reinigungsmitteln empfohlen. Die Verlegung in der Duschnische wird nicht empfohlen. / Décor avec lustres/métaux précieux à poser sur le mur. Lavage recommandé avec des détergents neutres, non abrasifs. Pose déconseillée dans la douche. / Decoración con elementos brillantes/metales preciosos utilizable para revestir superficies; se recomienda limpiarla con detergentes neutros, no abrasivos. Se desaconseja colocarla en el área de la ducha. / Декор с блестящим покрытием/драгоценными металлами, используемый для облицовки; рекомендуется чистка с использованием нейтральных, неабразивных моющих средств. Не рекомендуется укладка в душевой зоне.

\* \*

Il decoro ha una grafica direzionale, si consiglia di mantenere il verso in fase di posa. The patterning of the decoration has a set direction, which should be maintained during installation. Das Dekor ist richtungsgebunden. Es wird empfohlen, die Richtung bei der Verlegung beizubehalten. Le décor est directionnel. Il est recommandé de conserver le sens lors de la pose. La decoración presenta un gráfico direccional, por lo que se aconseja mantener el sentido durante la colocación. Графические элементы декора имеют определенное направление, которое мы рекомендуем соблюдать при укладке.

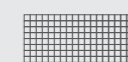

Mosaico preinciso da stuccare  
Pre-cut mosaic, requires grouting  
Mit Fugen zu verlegendes, vorgeschittenes Mosaik  
Mosaïque pré-coupée à jointoyer  
Mosaico preinciso para rejuntar  
Мозаика с насечкой для затирки

imballi / packaging / verpackungen / emballages / embalajes / упаковки

Scatole / Box / Karton / Boite / Caja / Коробки Pallet / Pallet / Palette / Palette / Pallet / Поддон

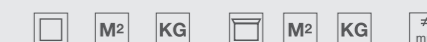

fondi / plain tiles / grundfliesen / fonds / fondos / фоновая плитка							
20x50 rivestimento	14	1,40	21,05	48	67,20	1010,47	8,5
20x50 mosaico	14	1,40	21,05	48	67,20	1010,47	8,5
decori / decorative pieces / dekore / décors / decoraciones / декоры							
20x50 decoro	14	1,40	21,05	48	67,20	1010,47	8,5
20x50	4	0,40	6,15				

# Replace

20x50



**R3QN** Replace Bianco  
20x50



**R3QT** Replace Bianco Struttura Vento 3D  
20x50

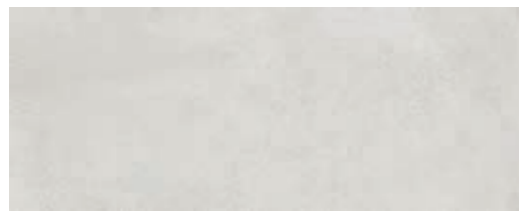

**R3QQ** Replace Grigio  
20x50



**R3QV** Replace Grigio Struttura Vento 3D  
20x50



**R3QS** Replace Antracite  
20x50



**R3QX** Replace Antracite Struttura Vento 3D  
20x50



**R3QP** Replace Beige  
20x50



**R3QU** Replace Beige Struttura Vento 3D  
20x50

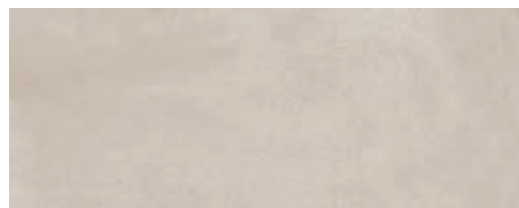

**R3QR** Replace Tortora  
20x50



**R3QW** Replace Tortora Struttura Vento 3D  
20x50

Abbinabile ai fondi / Matching with colours / Mit den Grundfliesen kombinierbar /  
Peut s'associer aux carreaux de base de couleurs / Puede combinarse con los fondos /  
Сочетается с фоновой плиткой:

Bianco, Grigio, Antracite

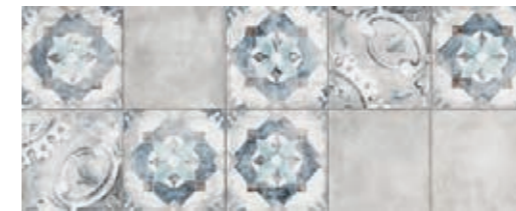

**R5JJ** Replace Decoro Tradizione Bianco  
20x50

Abbinabile ai fondi / Matching with colours / Mit den Grundfliesen kombinierbar /  
Peut s'associer aux carreaux de base de couleurs / Puede combinarse con los fondos /  
Сочетается с фоновой плиткой:

Beige, Tortora

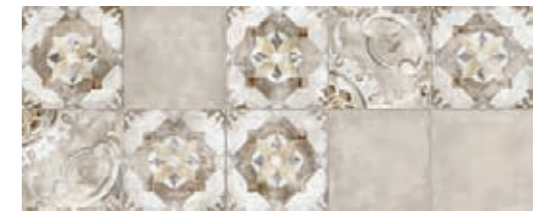

**R5JK** Replace Decoro Tradizione Beige  
20x50

Abbinabile ai fondi / Matching with colours / Mit den Grundfliesen kombinierbar /  
Peut s'associer aux carreaux de base de couleurs / Puede combinarse con los fondos /  
Сочетается с фоновой плиткой:

Bianco, Grigio, Antracite

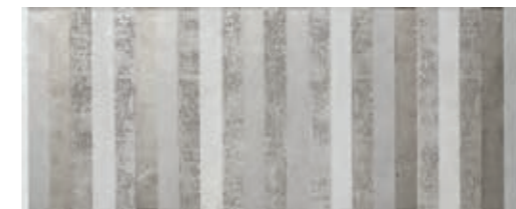

**R5PC** Replace Decoro Ritmo Bianco\*  
20x50

Abbinabile ai fondi / Matching with colours / Mit den Grundfliesen kombinierbar /  
Peut s'associer aux carreaux de base de couleurs / Puede combinarse con los fondos /  
Сочетается с фоновой плиткой:

Beige, Tortora

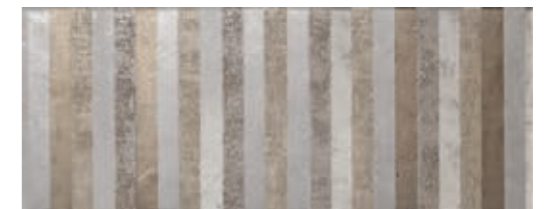

**R5PD** Replace Decoro Ritmo Beige\*  
20x50

# Replace

20x50



**R3QY** Replace Mosaico Bianco  
20x50



**R3RA** Replace Mosaico Grigio  
20x50



**R3QZ** Replace Mosaico Beige  
20x50

60x120 60x60 45x45 30x60

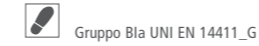

pavimenti coordinati / coordinated floor tiles / koordinierte bodenfliesen / sols coordonnes / pavimentos coordinados / координированные полы



H

**R48Q** Replace Bianco rettificato  
60x120

**R4NV** Replace Bianco rettificato  
**R5JF** Replace Bianco C2 rettificato \*\*  
60x60

**R55K** Replace Bianco rettificato  
45x45

**R4PF** Replace Bianco rettificato

**R4QE** Replace Bianco strutturato rettificato  
30x60



H

**R47Y** Replace Grigio rettificato  
60x120

**R4NT** Replace Grigio rettificato  
**R5JD** Replace Grigio C2 rettificato \*\*  
60x60

**R55J** Replace Grigio rettificato  
45x45

**R4PE** Replace Grigio rettificato

**R4QD** Replace Grigio strutturato rettificato  
30x60



H

**R47S** Replace Antracite rettificato  
60x120

**R4NS** Replace Antracite rettificato  
**R5JA** Replace Antracite C2 rettificato \*\*\*  
60x60

**R52J** Replace Antracite rettificato  
45x45

**R4PD** Replace Antracite rettificato

**R4QC** Replace Antracite strutturato rettificato  
30x60



G

**R48T** Replace Beige rettificato  
60x120

**R4NW** Replace Beige rettificato  
**R5JG** Replace Beige C2 rettificato \*\*  
60x60

**R55L** Replace Beige rettificato  
45x45

**R4PG** Replace Beige rettificato

**R4VY** Replace Beige strutturato rettificato  
30x60



H

**R48N** Replace Tortora rettificato  
60x120

**R4NU** Replace Tortora rettificato  
**R5JH** Replace Tortora C2 rettificato \*\*  
60x60

**R55M** Replace Tortora rettificato  
45x45

**R4PH** Replace Tortora rettificato

**R4VZ** Replace Tortora strutturato rettificato  
30x60

## tech info

\*

Decoro con lustri/metalli preziosi utilizzabile a rivestimento; si consiglia la pulizia con detersivi neutri, non abrasivi. È sconsigliata la posa nell'area doccia. / Decors with lustres/precious metals used for covering; we recommend cleaning with neutral, non-abrasive detergents. Tiles should not be installed in the shower area. / Dekor mit Glanzelementen/Edelmetallen für die Wandverkleidung; es wird die Reinigung mit neutralen, scheuermittelfreien Reinigungsmitteln empfohlen. Die Verlegung in der Duschnische wird nicht empfohlen. / Décor avec lustres/métaux précieux à poser sur le mur. Lavage recommandé avec des détergents neutres, non abrasifs. Pose déconseillée dans la douche. / Decoración con elementos brillantes/metales preciosos utilizable para revestir superficies; se recomienda limpiarla con detergentes neutros, no abrasivos. Se desaconseja colocarla en el área de la ducha. / Декор с блестящим покрытием/драгоценными металлами, используемый для облицовки; рекомендуется чистка с использованием нейтральных, неабразивных мощных средств. Не рекомендуется укладка в душевой зоне.

\*\*

C2: Classificazione in base alla normativa spagnola UNE – ENV 12633:2003 / Classification according to Spanish standard UNE – ENV 12633: 2003 / Klassifizierung gemäß der spanischen Norm UNE – ENV 12633:2003 / Classification selon la norme espagnole UNE-ENV 12633:2003 / Clasificación con arreglo a la norma española UNE – ENV 12633:2003 / Классификация в соответствии с испанским стандартом UNE – ENV 12633:2003



Mosaico preinciso da stuccare  
Pre-cut mosaic, requires grouting  
Mit Fugen zu verlegendes, vorgeschchnittenes Mosaik  
Mosaïque pré-coupée à jointoyer  
Mosaico preinciso para rejuntar  
Мозаика с насечкой для затирки

## imballi / packaging / verpackungen / emballages / embalajes / упаковки

Scatole / Box / Karton / Boite / Caja / Коробки	Pallet / Pallet / Palette / Palette / Pallet / Поддон				
		<b>M<sup>2</sup></b>	<b>KG</b>	<b>M<sup>2</sup></b>	<b>KG</b>

fondi / plain tiles / grundfliesen / fonds / fondos / фоновая плитка						
20x50 fondo / struttura 3D	14	1,40	21,05	48	67,20	1010,47
<b>decori</b> / decorative pieces / dekore / décors / decoraciones / декоры						
20x50 mosaico	14	1,40	21,05	48	67,20	1010,47
20x50 decora Tradizione	14	1,40	19,88	48	67,20	954,53
20x50 decora Ritmo	4	0,40	6,15			8,5

# Brass

25x38



**R2YL** Brass Argento  
25x38



**R3NQ** Brass Argento Struttura Marea 3D  
25x38

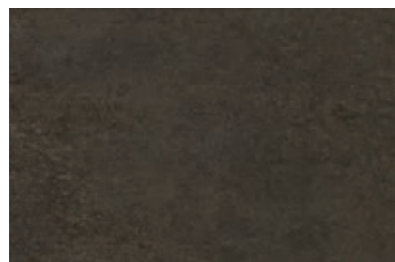

**R2YM** Brass Ferro  
25x38

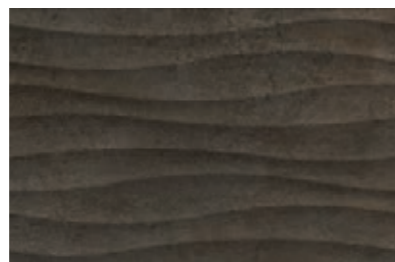

**R3NM** Brass Ferro Struttura Marea 3D  
25x38

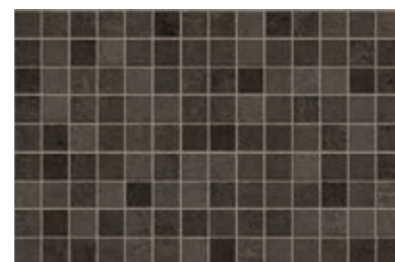

**R3ET** Brass Mosaico Ferro  
25x38

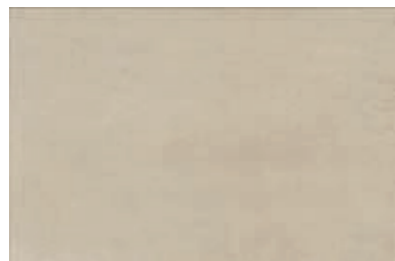

**R3EQ** Brass Beige  
25x38

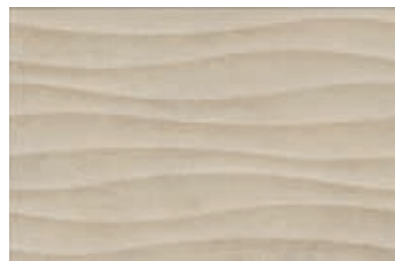

**R3NN** Brass Beige Struttura Marea 3D  
25x38

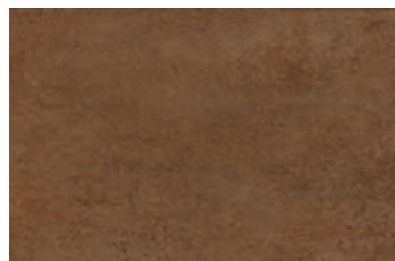

**R3ER** Brass Ossido  
25x38

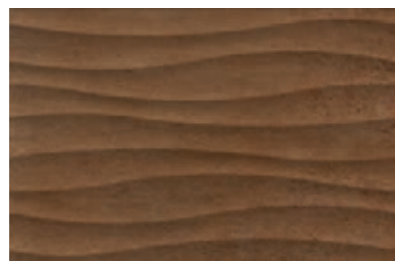

**R3NP** Brass Ossido Struttura Marea 3D  
25x38

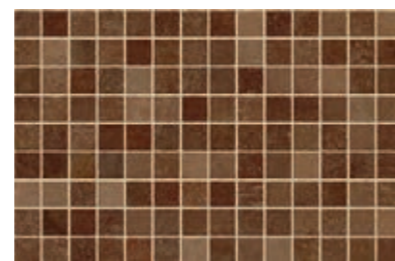

**R3GD** Brass Mosaico Ossido  
25x38

Abbinabile ai fondi / Matching with colours / Mit den Grundfliesen kombinierbar / Peut s'associer aux carreaux de base de couleurs / Puede combinarse con los fondos / Сочетается с фоновой плиткой.

Argento, Ferro



**R44A** Brass Decoro Lamina Argento  
25x38



**R47L** Brass Decoro Lamina Beige  
25x38



**R5QM** Brass Decoro Geo Argento\*  
25x38

Abbinabile ai fondi / Matching with colours / Mit den Grundfliesen kombinierbar / Peut s'associer aux carreaux de base de couleurs / Puede combinarse con los fondos / Сочетается с фоновой плиткой.

Beige, Ossido



**R47L** Brass Decoro Lamina Beige  
25x38



**R5QN** Brass Decoro Geo Beige\*  
25x38

## tech info



Mosaico preinciso da stuccare  
Pre-cut mosaic, requires grouting  
Mit Fugen zu verlegendes, vorgeschchnittenes Mosaik  
Mosaïque pré-coupée à jointoyer  
Mosaico preinciso para rejuntar  
Мозаика с насечкой для затирки

★

Decoro con lustri/metalli preziosi utilizzabile a rivestimento; si consiglia la pulizia con detersivi neutri, non abrasivi. È sconsigliata la posa nell'area doccia. / Decors with lustres/precious metals used for covering; we recommend cleaning with neutral, non-abrasive detergents. Tiles should not be installed in the shower area. / Dekor mit Glanzelementen/Edelmetallen für die Wandverkleidung; es wird die Reinigung mit neutralen, scheuermittelfreien Reinigungsmitteln empfohlen. Die Verlegung in der Duschnische wird nicht empfohlen. / Décor avec lustres/métaux précieux à poser sur le mur. Lavage recommandé avec des détergents neutres, non abrasifs. Pose déconseillée dans la douche. / Decoración con elementos brillantes/metales preciosos utilizable para revestir superficies; se recomienda limpiarla con detergentes neutros, no abrasivos. Se desaconseja colocarla en el área de la ducha. / Декор с блестящим покрытием/драгоценными металлами, используемый для облицовки; рекомендуется чистка с использованием нейтральных, неабразивных моющих средств. Не рекомендуется укладка в душевой зоне.

## imballi / packaging / verpackungen / emballages / embalajes / упаковки

Scatole / Box / Karton / Boite / Caja / Коробки

Pallet / Pallet / Palette / Palette / Pallet / Поддон



fondi / plain tiles / grundfliesen / fonds / fondos / фоновая плитка

25x38	14	1,33	19,60	54	71,82	1058,51	8,5
25x38 struttura Marea 3D	14	1,33	19,60	54	71,82	1058,51	8,5

decori / decorative pieces / dekore / décors / decoraciones / декоры

25x38 mosaico	14	1,33	19,60	54	71,82	1058,51	8,5
25x38 decoro Lamina	14	1,33	19,60	54	71,82	1058,51	8,5
25x38 decoro Geo	4	0,38	5,48				

# Casablanca

25x38



**R3XP** Casablanca Bianco  
25x38



**R3TM** Casablanca Beige  
25x38

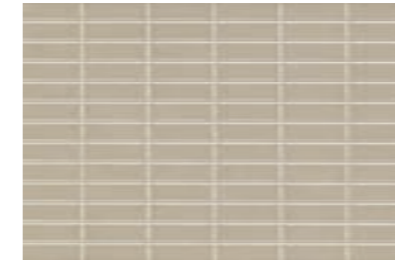

**R3VM** Casablanca Mosaico Beige  
25x38



**R3WV** Casablanca Decoro Beige  
25x38

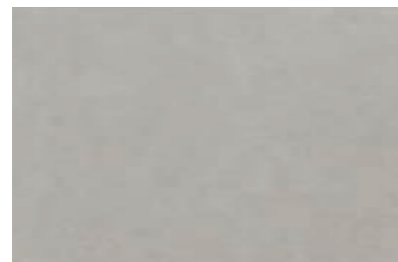

**R3TQ** Casablanca Grigio  
25x38

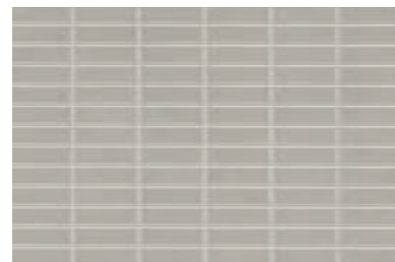

**R3VQ** Casablanca Mosaico Grigio  
25x38



**R3WZ** Casablanca Decoro Grigio  
25x38

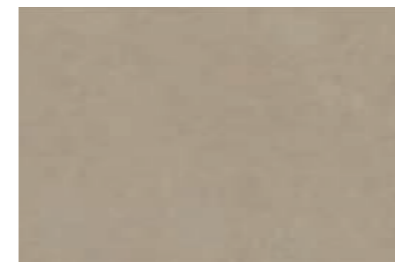

**R3TN** Casablanca Creta  
25x38

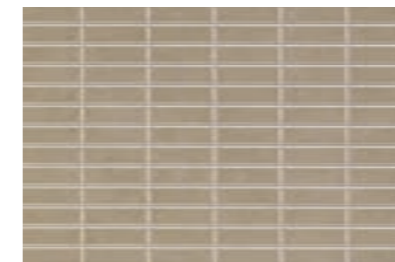

**R3VN** Casablanca Mosaico Creta  
25x38



**R3WW** Casablanca Decoro Creta  
25x38



**R3TR** Casablanca Antracite  
25x38

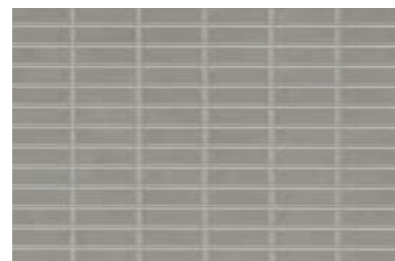

**R3VR** Casablanca Mosaico Antracite  
25x38



**R3WY** Casablanca Decoro Antracite  
25x38

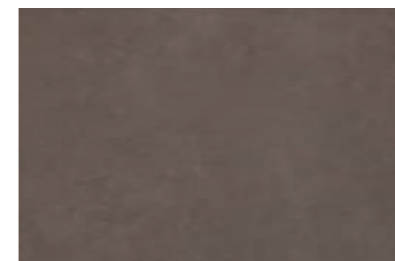

**R3TP** Casablanca Marrone  
25x38



**R3VP** Casablanca Mosaico Marrone  
25x38



**R3WX** Casablanca Decoro Marrone  
25x38

Abbinabile ai fondi / Matching with colours / Mit den Grundfliesen kombinierbar / Peut s'associer aux carreaux de base de couleurs / Puede combinarse con los fondos / Сочетается с фоновой плиткой:

Beige, Creta, Marrone



**R3XA** Casablanca Decoro Marrone\*  
25x38

Abbinabile ai fondi / Matching with colours / Mit den Grundfliesen kombinierbar / Peut s'associer aux carreaux de base de couleurs / Puede combinarse con los fondos / Сочетается с фоновой плиткой:

Grigio, Antracite



**R3XC** Casablanca Decoro Antracite\*  
25x38



**R3XD** Casablanca Decoro Beige  
25x38



**R3WU** Casablanca L. Grigio  
4,5x38



**R3WT** Casablanca L. Beige  
4,5x38

60x60 45x45 30x60 33,3x33,3



Gruppo Bili UNI EN 14411\_G

pavimenti coordinati / coordinated floor tiles / koordinierte bodenfliesen / sols coordonnés / pavimentos coordinados / координированные полы



G

**R3KQ** Casablanca GR rettificato  
60x60

**R3LD** Casablanca GR  
45x45

**R3KW** Casablanca GR rettificato  
30x60

**R51S** Casablanca GR  
33,3x33,3



G

**R3KR** Casablanca AN rettificato  
60x60

**R3LE** Casablanca AN  
45x45

**R3KX** Casablanca AN rettificato  
30x60

**R51T** Casablanca AN  
33,3x33,3

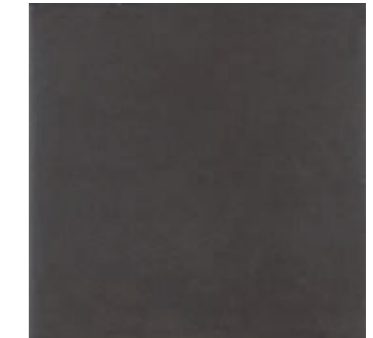

F

**R3KS** Casablanca NE rettificato  
60x60

**R3LF** Casablanca NE  
45x45

**R3KY** Casablanca NE rettificato  
30x60

**R51U** Casablanca NE  
33,3x33,3

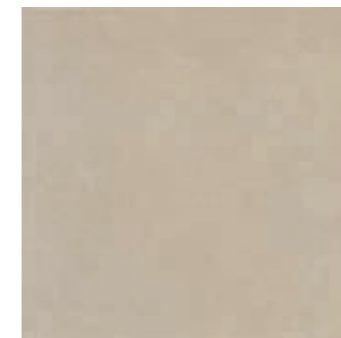

G

**R3KM** Casablanca BG rettificato  
60x60

**R3KZ** Casablanca BG  
45x45

**R3KT** Casablanca BG rettificato  
30x60

**R51P** Casablanca BG  
33,3x33,3

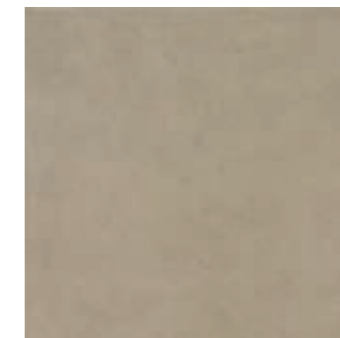

G

**R3KN** Casablanca CR rettificato  
60x60

**R3LA** Casablanca CR  
45x45

**R3KU** Casablanca CR rettificato  
30x60

**R51Q** Casablanca CR  
33,3x33,3

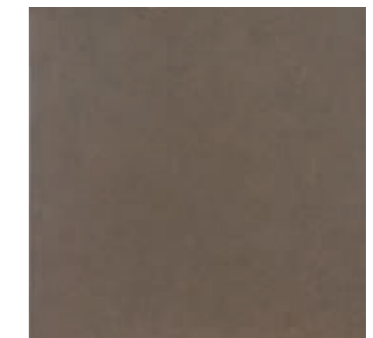

F

**R3KP** Casablanca MA rettificato  
60x60

**R3LC** Casablanca MA  
45x45

**R3KV** Casablanca MA rettificato  
30x60

**R51R** Casablanca MA  
33,3x33,3

## tech info

\*

Decoro con lustri/metalli preziosi utilizzabile a rivestimento; si consiglia la pulizia con detergenti neutri, non abrasivi. È sconsigliata la posa nell'area doccia. / Decors with lustres/precious metals used for covering; we recommend cleaning with neutral, non-abrasive detergents. Tiles should not be installed in the shower area. / Dekor mit Glanzelementen/Edelmetallen für die Wandverkleidung; es wird die Reinigung mit neutralen, scheuermittelfreien Reinigungsmitteln empfohlen. Die Verlegung in der Duschnische wird nicht empfohlen. / Décor avec lustres/métaux précieux à poser sur le mur. Lavage recommandé avec des détergents neutres, non abrasifs. Pose déconseillée dans la douche. / Decoración con elementos brillantes/metales preciosos utilizable para revestir superficies; se recomienda limpiarla con detergentes neutros, no abrasivos. Se desaconseja colocarla en el área de la ducha. / Декор с блестящим покрытием/драгоценными металлами, используемый для облицовки; рекомендуется чистка с использованием нейтральных, неабразивных моющих средств. Не рекомендуется укладка в душевой зоне.



Mosaico preinciso da stuccare / Pre-cut mosaic, requires grouting / Mit Fugen zu verlegendes, vorgeschchnittenes Mosaik / Mosaïque pré-coupée à jointoyer / Mosaico preinciso para rejuntar / Мозаика с насечкой для затирки

imballi / packaging / verpackungen / emballages / embalajes / упаковки

Scatole / Box / Karton / Boite / Caja / Коробки Pallet / Pallet / Palette / Palette / Поддон



fondi / plain tiles / grundfliesen / fonds / fondos / фоновая плитка

25x38	14	1,33	19,40	54	71,82	1047,86	8,5
25x38 mosaico	14	1,33	19,40	54	71,82	1047,86	8,5

decori / decorative pieces / dekore / décors / decoraciones / декоры

25x38 decoro	14	1,33	19,40	54	71,82	1047,86	8,5
25x38 dec. R3XA/R3XC/R3XD	4	0,38	5,48				
4,5x38 L.	6	0,10	1,48				



# Colours

25x38



**R2LL** Colours Ivory  
25x38



**R2LM** Colours Beige  
25x38



**R2LN** Colours Brown  
25x38

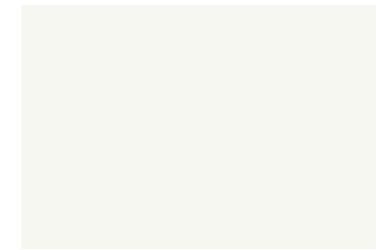

**R2LF** Colours White  
25x38

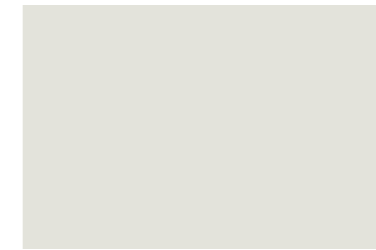

**R2LG** Colours Silver  
25x38



**R2LH** Colours Grey  
25x38

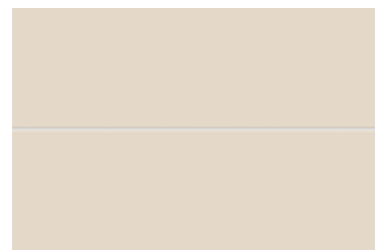

**R2PZ** Colours Listellato Ivory  
25x38

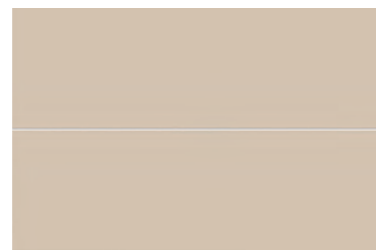

**R2QA** Colours Listellato Beige  
25x38



**R2QC** Colours Listellato Brown  
25x38



**R2PW** Colours Listellato White  
25x38



**R2PX** Colours Listellato Silver  
25x38

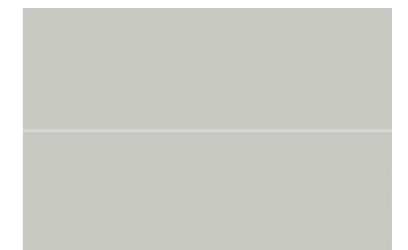

**R2PY** Colours Listellato Grey  
25x38

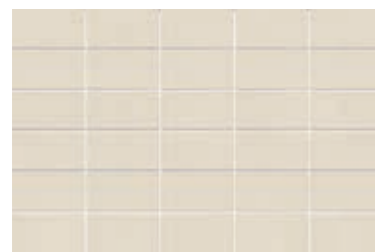

**R2QL** Colours Mosaico Ivory  
25x38

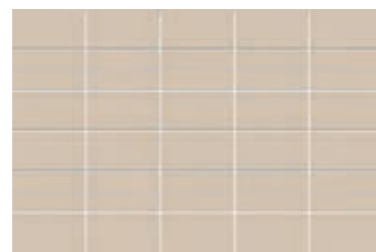

**R2QM** Colours Mosaico Beige  
25x38

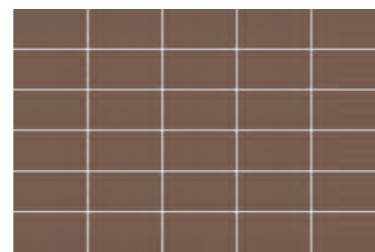

**R2QN** Colours Mosaico Brown  
25x38

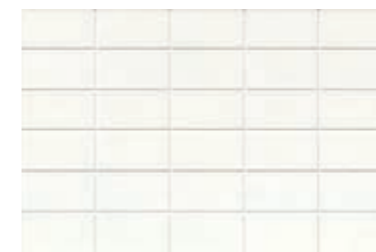

**R2QH** Colours Mosaico White  
25x38



**R2QJ** Colours Mosaico Silver  
25x38



**R2QK** Colours Mosaico Grey  
25x38

Abbinabile ai fondi / Matching with colours / Mit den Grundfliesen kombinierbar / Peut s'associer aux carreaux de base de couleurs / Puede combinarse con los fondos / Сочетается с фоновой плиткой:

White, Silver, Grey

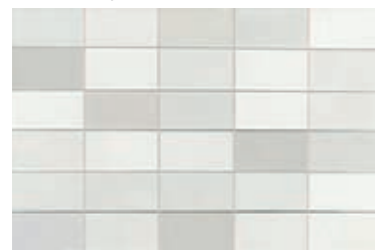

**R2QU** Colours Mosaico Mix Silver  
25x38

Abbinabile ai fondi / Matching with colours / Mit den Grundfliesen kombinierbar / Peut s'associer aux carreaux de base de couleurs / Puede combinarse con los fondos / Сочетается с фоновой плиткой:

Ivory, Beige

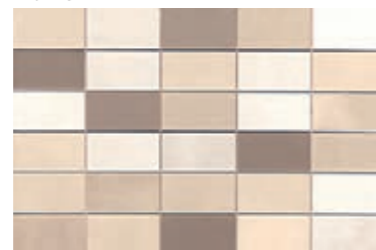

**R2QX** Colours Mosaico Mix Beige  
25x38

Abbinabile ai fondi / Matching with colours / Mit den Grundfliesen kombinierbar / Peut s'associer aux carreaux de base de couleurs / Puede combinarse con los fondos / Сочетается с фоновой плиткой:

Brown



**PEQ1** L. Brown  
5x38

Abbinabile ai fondi / Matching with colours / Mit den Grundfliesen kombinierbar / Peut s'associer aux carreaux de base de couleurs / Puede combinarse con los fondos / Сочетается с фоновой плиткой:

White, Silver, Grey, Black, Orange, Red, Blue



**PEQ8** L. Metallo  
3x38

Abbinabile ai fondi / Matching with colours / Mit den Grundfliesen kombinierbar / Peut s'associer aux carreaux de base de couleurs / Puede combinarse con los fondos / Сочетается с фоновой плиткой:

Ivory, Beige



**PEQ0** L. Beige  
5x38

Abbinabile ai fondi / Matching with colours / Mit den Grundfliesen kombinierbar / Peut s'associer aux carreaux de base de couleurs / Puede combinarse con los fondos / Сочетается с фоновой плиткой:

Ivory, Beige, Brown



**PEQ7** L. Beige  
4x38

Abbinabile ai fondi / Matching with colours / Mit den Grundfliesen kombinierbar / Peut s'associer aux carreaux de base de couleurs / Puede combinarse con los fondos / Сочетается с фоновой плиткой:

White, Grey

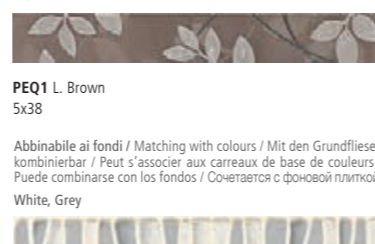

**PEQ6** L. Grey  
4x38

## tech info



Mosaico preinciso da stuccare  
Pre-cut mosaic, requires grouting  
Mit Fugen zu verlegendes, vorgeschchnittenes Mosaik  
Mosaïque pré-coupée à jointoyer  
Mosaico preinciso para rejuntar  
Мозаика с насечкой для затирки

•  
Vedi Appendice pag. 585  
See Appendix page 585  
Siehe Anhang S. 585  
Voir Annexe page 585  
Véase la pág. 585 del Apéndice  
Смотри приложение на стр. 585

## imballi / packaging / verpackungen / emballages / embalajes / упаковки

Scatole / Box / Karton / Boite / Caja / Коробки

Pallet / Pallet / Palette / Palette / Pallet / Поддон



fondi / plain tiles / grundfliesen / fonds / fondos / фоновая плитка								
25x38		14	1,33	19,66	54	71,82	1061,48	8,5
25x38	listellato	14	1,33	19,66	54	71,82	1061,48	8,5
25x38	mosaico / mos. mix	14	1,33	19,66	54	71,82	1061,48	8,5
decori / decorative pieces / dekore / décors / decoraciones / декоры								
5x38	L.	6	0,11	1,68				
4x38	L.	6	0,09	1,26				
3x38	L. Metallo	6	0,07	1,17				

# Craft

25x38

rivestimenti in pasta bianca / white body wall tiles / wandfliesen aus weissen ton scherben / revetements en pate blanche / revestimientos en pasta blanca / облицовка из белой глины

superfici / surfaces / finitions / oberflächen / superficies / поверхности: **matt**



**R2FP** Craft Beige  
25x38



**R2SF** Craft Beige Struttura Marea 3D  
25x38



**R2FT** Craft Mosaico Beige  
25x38

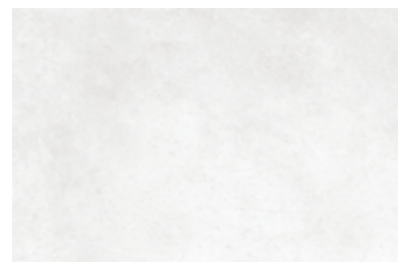

**R2FQ** Craft Bianco  
25x38



**R2TC** Craft Bianco Struttura Marea 3D  
25x38



**R2FR** Craft Grigio  
25x38



**R2TD** Craft Grigio Struttura Marea 3D  
25x38



**R2FU** Craft Mosaico Grigio  
25x38



**R2FS** Craft Blu  
25x38

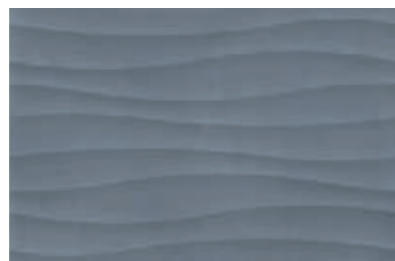

**R2VQ** Craft Blu Struttura Marea 3D  
25x38

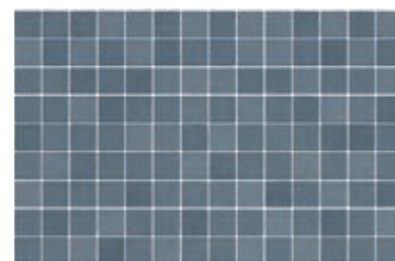

**R2KL** Craft Mosaico Blu  
25x38

Abbinabile ai fondi / Matching with colours / Mit den Grundfliesen kombinierbar / Peut s'associer aux carreaux de base de couleurs / Puede combinarse con los fondos / Сочетается с фоновой плиткой:

Beige, Blu



**R2YG** Craft Decoro Liberty Beige  
25x38



Bianco, Grigio, Blu



**R2YH** Craft Decoro Liberty Grigio  
25x38

Abbinabile ai fondi / Matching with colours / Mit den Grundfliesen kombinierbar / Peut s'associer aux carreaux de base de couleurs / Puede combinarse con los fondos / Сочетается с фоновой плиткой:

Beige



**R2VR** Craft Decoro Relax Beige  
25x38

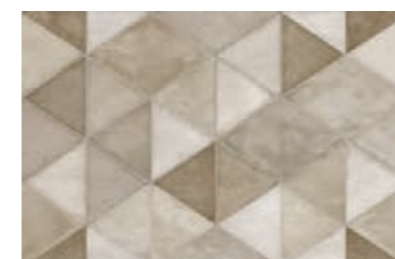

Bianco, Grigio, Blu

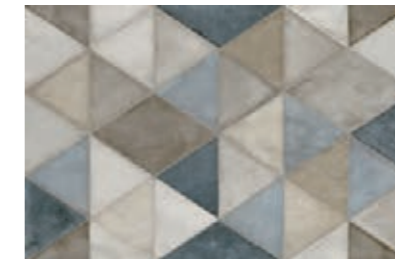

**R2YF** Craft Decoro Relax Grigio  
25x38

## tech info



Mosaico preinciso da stuccare  
Pre-cut mosaic, requires grouting  
Mit Fugen zu verlegendes, vorgeschchnittenes Mosaik  
Mosaïque pré-coupée à jointoyer  
Mosaico preinciso para rejuntar  
Мозаика с насечкой для затирки

## imballi / packaging / verpackungen / emballages / embalajes / упаковки

Scatole / Box / Karton /  
Boîte / Caja / Коробки

Pallet / Pallet / Palette /  
Palette / Pallet / Поддон



fondi / plain tiles / grundfliesen / fonds / fondos / фоновая плитка	25x38	fondo / struttura 3D	14	1,33	19,60	54	71,82	1058,46	8,5
decori / decorative pieces / dekore / décors / decoraciones / декоры	25x38	decoro / mosaico	14	1,33	19,60	54	71,82	1058,46	8,5

# Energy

25x38



**rivestimenti in pasta bianca** / white bodywall tiles / wandfliesen aus weissen ton scherben / revetements en pate blanche / revestimientos en pasta blanca / облицовка из белой глины

**superfici** / surfaces / finitions / oberflächen / superficies / поверхности:  
**glossy**



**R00V** Energy Bianco  
25x38



**R00W** Energy Perla  
25x38



**R011** Energy Avorio  
25x38



**R00X** Energy Turchese  
25x38



**R00Y** Energy Indaco  
25x38



**R00Z** Energy Magenta  
25x38



**R018** Energy Bianco Struttura Marea 3D  
25x38



**R019** Energy Perla Struttura Marea 3D  
25x38



**R01D** Energy Avorio Struttura Marea 3D  
25x38



**R01A** Energy Turchese Struttura Marea 3D  
25x38

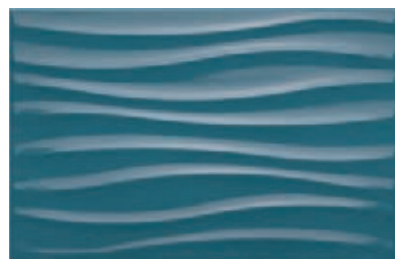

**R01C** Energy Indaco Struttura Marea 3D  
25x38

Abbinabile ai fondi / Matching with colours / Mit den Grundfliesen kombinierbar / Peut s'associer aux carreaux de base de couleurs / Puede combinarse con los fondos / Сочетается с фоновой плиткой:

Bianco, Perla



**R01G** Energy Mosaico Avorio  
25x38



**R01E** Energy Mosaico Bianco  
25x38

Abbinabile ai fondi / Matching with colours / Mit den Grundfliesen kombinierbar / Peut s'associer aux carreaux de base de couleurs / Puede combinarse con los fondos / Сочетается с фоновой плиткой:



**R01J** Energy Decoro Faience Bianco  
25x38

Abbinabile ai fondi / Matching with colours / Mit den Grundfliesen kombinierbar / Peut s'associer aux carreaux de base de couleurs / Puede combinarse con los fondos / Сочетается с фоновой плиткой:

Bianco, Perla, Indaco



**R012U** Energy Decoro Kimono Bianco  
25x38

Abbinabile ai fondi / Matching with colours / Mit den Grundfliesen kombinierbar / Peut s'associer aux carreaux de base de couleurs / Puede combinarse con los fondos / Сочетается с фоновой плиткой:



**R01K** Energy Decoro Faience Avorio  
25x38

Abbinabile ai fondi / Matching with colours / Mit den Grundfliesen kombinierbar / Peut s'associer aux carreaux de base de couleurs / Puede combinarse con los fondos / Сочетается с фоновой плиткой:

Avorio, Magenta



**R012V** Energy Decoro Kimono Avorio  
25x38

## tech info



Mosaico preinciso da stuccare  
Pre-cut mosaic, requires grouting  
Mit Fugen zu verlegendes, vorgeschchnittenes Mosaik  
Mosaïque pré-coupée à jointoyer  
Mosaico preinciso para rejuntar  
Мозаика с насечкой для затирки

## imballi / packaging / verpackungen / emballages / embalajes / упаковки

Scatole / Box / Karton / Boite / Caja / Коробки Pallet / Pallet / Palette / Palette / Pallet / Поддон

	M <sup>2</sup>	KG		M <sup>2</sup>	KG	≠ mm
--	----------------	----	--	----------------	----	------

fondi / plain tiles / grundfliesen / fonds / fondos / фоновая плитка						
25x38	14	1,33	19,92	54	71,82	1075,80
25x38 struttura	14	1,33	20,41	54	71,82	1102,10
25x38 mosaico	14	1,33	20,41	54	71,82	1102,10
decori / decorative pieces / dekore / décors / decoraciones / декоры						
25x38 decoro Faience	14	1,33	20,01	54	71,82	1080,55
25x38 decoro Kimono	4	0,38	6,00			

# Feel

25x38



**R01M** Feel Bianco  
25x38



**R01N** Feel Grigio  
25x38



**R01P** Feel Cenere  
25x38



**R01T** Feel Avorio  
25x38



**R01S** Feel Tortora  
25x38



**R01R** Feel Corallo  
25x38

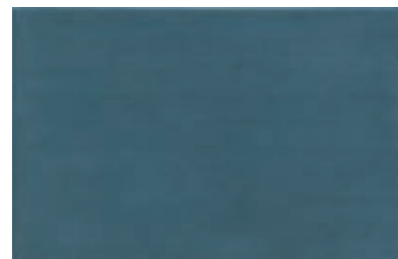

**R01Q** Feel Blu  
25x38



**R01U** Feel Bianco Struttura Marea 3D  
25x38



**R01V** Feel Cenere Struttura Marea 3D  
25x38



**R01Y** Feel Avorio Struttura Marea 3D  
25x38



**R01X** Feel Tortora Struttura Marea 3D  
25x38



**R01W** Feel Blu Struttura Marea 3D  
25x38

Abbinabile ai fondi / Matching with colours / Mit den Grundfliesen kombinierbar / Peut s'associer aux carreaux de base de couleurs / Puede combinarse con los fondos / Сочетается с фоновой плиткой:

Bianco, Grigio, Cenere, Blu



**R025** Feel Decoro Fusion Bianco  
25x38

Abbinabile ai fondi / Matching with colours / Mit den Grundfliesen kombinierbar / Peut s'associer aux carreaux de base de couleurs / Puede combinarse con los fondos / Сочетается с фоновой плиткой:

Avorio, Tortora, Corallo



**R02A** Feel Decoro Fusion Avorio  
25x38

Abbinabile ai fondi / Matching with colours / Mit den Grundfliesen kombinierbar / Peut s'associer aux carreaux de base de couleurs / Puede combinarse con los fondos / Сочетается с фоновой плиткой:

Grigio, Cenere, Bianco



**R11U** Feel Decoro Wallpaper Grigio\*  
25x38

Abbinabile ai fondi / Matching with colours / Mit den Grundfliesen kombinierbar / Peut s'associer aux carreaux de base de couleurs / Puede combinarse con los fondos / Сочетается с фоновой плиткой:

Avorio, Tortora



**R11T** Feel Decoro Wallpaper Avorio\*  
25x38

Abbinabile ai fondi / Matching with colours / Mit den Grundfliesen kombinierbar / Peut s'associer aux carreaux de base de couleurs / Puede combinarse con los fondos / Сочетается с фоновой плиткой:

Bianco, Grigio

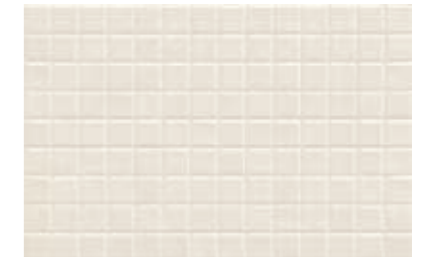

**R01Z** Feel Mosaico Bianco  
25x38



**R024** Feel Mosaico Avorio  
25x38

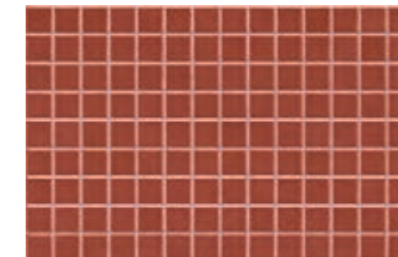

**R022** Feel Mosaico Corallo  
25x38



**R020** Feel Mosaico Cenere  
25x38

## tech info



Mosaico preinciso da stuccare  
Pre-cut mosaic, requires grouting  
Mit Fugen zu verlegendes, vorgeschchnittenes Mosaik  
Mosaïque pré-coupée à jointoyer  
Mosaico preinciso para rejuntar  
Мозаика с насечкой для затирки

## \*

Decoro con lustrì/metalli preziosi utilizzabile a rivestimento; si consiglia la pulizia con detergenti neutri, non abrasivi. È sconsigliata la posa nell'area doccia. / Decors with lustres/precious metals used for covering; we recommend cleaning with neutral, non-abrasive detergents. Tiles should not be installed in the shower area. / Dekor mit Glanzelementen/Edelmetallen für die Wandverkleidung; es wird die Reinigung mit neutralen, scheuemittelfreien Reinigungsmitteln empfohlen. Die Verlegung in der Duschnische wird nicht empfohlen. / Décor avec lustres/métaux précieux à poser sur le mur. Lavage recommandé avec des détergents neutres, non abrasifs. Pose déconseillée dans la douche. / Decoración con elementos brillantes/metales preciosos utilizable para revestir superficies; se recomienda limpiarla con detergentes neutros, no abrasivos. Se desaconseja colocarla en el área de la ducha. / Декор с блестящим покрытием/драгоценными металлами, используемый для облицовки; рекомендуется чистка с использованием нейтральных, неабразивных моющих средств. Не рекомендуется укладка в душевой зоне.

## imballi / packaging / verpackungen / emballages / embalajes / упаковки

Scatole / Box / Karton / Boite / Caja / Коробки

Pallet / Pallet / Palette / Palette / Pallet / Поддон



## fondi / plain tiles / grundfliesen / fonds / fondos / фоновая плитка

	14	1,33	19,62	54	71,82	1059,36	8,5
25x38 struttura	14	1,33	17,80	54	71,82	961,04	8,5
25x38 mosaico	14	1,33	20,41	54	71,82	1102,10	8,5

## decori / decorative pieces / dekore / décors / decoraciones / декоры

	14	1,33	20,01	54	71,82	1080,55	8,5
25x38 Decoro Fusion	14	1,33	20,01	54	71,82	1080,55	8,5
25x38 Decoro Wallpaper	4	0,38	6,01				

# Focus

25x38



rivestimenti in pasta bianca / white bodywall tiles / wandfliesen aus weissen ton scherben / revêtements en pate blanche / revestimientos en pasta blanca / облицовка из белой глины

superfici / surfaces / finitions / oberflächen / superficies / поверхности:  
**matt**



**R2KN** Focus Beige  
25x38



**R2KM** Focus Grey  
25x38



**R2KP** Focus Brown  
25x38



**R2KQ** Focus Black  
25x38

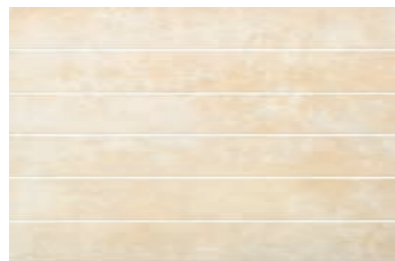

**R2LZ** Focus Listellato Beige  
25x38

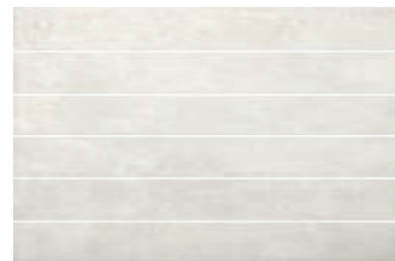

**R2LW** Focus Listellato Grey  
25x38



**R2LY** Focus Listellato Brown  
25x38



**R2LX** Focus Listellato Black  
25x38

Abbinabile ai fondi / Matching with colours / Mit den Grundfliesen kombinierbar / Peut s'associer aux carreaux de base de couleurs / Puede combinarse con los fondos / Сочетается с фоновой плиткой:  
Beige, Brown, Grey, Black



**PEQ8** L. Metallo •  
3x38

Abbinabile ai fondi / Matching with colours / Mit den Grundfliesen kombinierbar / Peut s'associer aux carreaux de base de couleurs / Puede combinarse con los fondos / Сочетается с фоновой плиткой:  
Beige, Brown



**DR62** L. Beige  
3x38

Abbinabile ai fondi / Matching with colours / Mit den Grundfliesen kombinierbar / Peut s'associer aux carreaux de base de couleurs / Puede combinarse con los fondos / Сочетается с фоновой плиткой:  
Grey, Black



**DR61** L. Grey  
3x38

**CAJ5** L. Metallo •  
1,5x38

## tech info



Mosaico preinciso da stuccare  
Pre-cut mosaic, requires grouting  
Mit Fugen zu verlegendes, vorgeschchnittenes Mosaik  
Mosaïque pré-coupée à jointoyer  
Mosaico preinciso para rejuntar  
Мозаика с насечкой для затирки

•  
Vedi Appendice pag. 585  
See Appendix page 585  
Siehe Anhang S. 585  
Voir Annexe page 585  
Véase la pág. 585 del Apéndice  
Смотри приложение на стр. 585

## imballi / packaging / verpackungen / emballages / embalajes / упаковки

Scatole / Box / Karton / Boite / Caja / Коробки Pallet / Pallet / Palette / Palette / Pallet / Поддон



fondi / plain tiles / grundfliesen / fonds / fondos / фоновая плитка		M²		KG		mm	
25x38		14	1,33	19,66	54	71,82	1061,48
decori / decorative pieces / dekore / décors / decoraciones / декоры		M²		KG		mm	
3x38	L.	6	0,07	1,17			
1,5x38	L. Metallo	18	0,10	2,12			



<b>Lettura del catalogo</b> <b>586</b>	<b>Qualità e ambiente</b> <b>604</b>
reading the catalogue / benützung des kataloges / la lecture du catalogue / la lectura del catálogo / чтение каталога	quality and environment / qualität und umwelt / la qualité et l'environnement / calidad y ambiente / качество и окружающая среда
<b>Legenda</b> <b>588</b>	<b>Le norme UNI EN</b> <b>606</b>
legend / legende / legende / leyenda / условные знаки	UNI EN regulations / die UNI EN-normen / les normes UNI EN / las normas UNI EN / нормы UNI EN
<b>Simbologia</b> <b>590</b>	<b>Caratteristiche tecniche (HIGH PERFORMANCE)</b> <b>608</b>
key to symbols / symbole / symbologie / simbologia / символы	technical characteristics / technische eigenschaften / caracteristiques technique / datos tecnicos / технические характеристики
<b>Variazioni cromatiche</b> <b>591</b>	<b>Caratteristiche tecniche (MAIORA)</b> <b>610</b>
colour variations / colour variations / variations chromatiques / farbvariationen / variaciones cromáticas / варианты оттенка	technical characteristics / technische eigenschaften / caracteristiques technique / datos tecnicos / технические характеристики
<b>Pezzi speciali</b> <b>592</b>	<b>Imballaggio (MAIORA)</b> <b>614</b>
trims / spezialteile / pièces spéciales / piezas especiales / специальные изделия	packaging / Verpackung / emballage / embalajes / упаковка
<b>Destinazione d'uso</b> <b>598</b>	<b>Consigli di posa e manutenzione</b> <b>616</b>
intended use / anwendungsbereich / champ d'application / uso previsto / назначение	advice for laying and maintenance / verlegungs- und Pflegehinweise / conseils pour la pose et l'entretien / consejos de colocación y mante- nimiento / рекомендации по укладке и уходу
<b>Certificazioni</b> <b>599</b>	<b>Norme di trattamento</b> <b>622</b>
certifications / zertifizierungen / certificacions / certificaciones / сертификации	treatment procedures / normes de traitement / behandlungshinweise / normas de tratamiento / правила промывки

**1** → **Woodside**  
 30x120 20x120 15x120

**6** →

RSPH Woodside Marrone rettificato 30x120

218

- 1** serie / series / serie / serie / серия
- 2** codice / code / artikel-nummer / code / código / код
- 3** articolo / article / artikel / article / artículo / артикул
- 4** formato / size / format / format / formato / формат

Gruppo B1a UNI EN 14411\_G

gres fine porcellanato colorato in massa - rettificato monocillibro / colorbody fine porcelain stoneware - rectified monocillibro / durchgefärbtes feinsteinzeug - rektifiziert in einem werkmaß / gris ébène fin colorié dans la masse - rectifié monocillibro / gres porcelánico fino coloreado en toda la masa - retificado monocillibro / российский мелкозернистый керамогранит - ректифицированный монокалибровый

superfici / surfaces / finitions / oberflächen / superficies / поверхности  
 naturale/matt

wood effect

219

- 5** destinazione d'uso / intended use / anwendungsbereich / champ d'application / uso previsto / назначение
- 6** caratteristiche tecniche - certificazioni / technical characteristics - certifications / technische eigenschaften - zertifizierungen / caracteristiques technique - certifications / datos tecnicos - certificaciones / технические характеристики - сертификаты
- 7** superfici / surfaces / oberflächen / finitions / superficies / поверхности
- 8** tecnologia / technology / technik / la technologie / tecnología / технология

LEGEND **LEGENDA**

legende - legende - leyenda - условные знаки

<b>A.E.</b>	angolo esterno outside corner außenwinkel angle sortant ángulo exterior внешний угол	<b>B.T.S.</b>	battistraccio concave skirting tile hohlkehlfiese gorge horizontale zócalo плитка со встроенным плинтусом	<b>FR.</b>	freccia interlocking tile pfeil freccia collee flecha мозаичное украшение на сетке	<b>P.C.</b>	punto colla chequered tile punktgeklebt point de colle punto cola точка нанесения клея	<b>SP.SGU.</b>	spigolo sguscia cove base external corner kehlsöckel-aussenecken plinthe a talon angle sortant esquina escocia наружный угол плитуса с загибом вверх
<b>A.I.</b>	angolo interno inside corner innenwinkel angle rentrant ángulo interior внутренний угол	<b>C.</b>	copribordo edge cover / v-cap randfliese moulure de finition cubreborde бортовая плитка	<b>GR.</b>	gradone step linear tile laufende stufe nez de marche lineaire peldano плитка для края ступеньки с загибом	<b>R.</b>	raccordo cove base gefästere sockel raccord enlace соединительный элемент	<b>T.</b>	tozzetto dot tile einlegestück cabochon taco вставка
<b>AL.</b>	alzata high skirting tile sockelleiste f. Wandfliesen plinthe haute zócalo высокий плитус	<b>C.ANG.</b>	copribordo angolare edge cover angle / v-cap corner randecke moulure de finition angle sortant cubreborde angular угловая бортовая плитка	<b>GR.ANG.</b>	gradone angolare step corner tile winkelstufe nez de marche d'angle peldano angular угловая плитка для края ступеньки с загибом	<b>S.</b>	sigaro cigar tile sigaro-schmale bordüre cigare sigaro сигара	<b>TO.</b>	torello round end piece torello torello угловой загиб
<b>AN.</b>	angolo internal corner ecke angle rentrant angolo угол	<b>CN.E.</b>	canaletta esterna external channel / bead ausserrinne caniveau exterieur media caña externa наружный канал	<b>L.</b>	listello edging tile leiste listel listelo бордюр	<b>SC.</b>	scalino stairtread stufe marche escalón плитка для края ступеньки	<b>U.</b>	unghia interna internal combination piece ongles / beak innenecken zur rinnleiste angle rentrant encuentro escocia внутренний угол
<b>AN.AL.</b>	angolo alzata high skirting tile corner außenecke f. Sockelleiste angle plinthe haute ángulo zócalo высокий угол	<b>CN.I.</b>	canaletta interna internal channel innenrinne caniveau interieur media caña interna внутренний канал	<b>LO.</b>	london london london london london лондон	<b>SP.</b>	spigolo external corner aussenecken angle sortant esquina плинтус с загибом вверх (внутренний угол)	<b>UE.</b>	unghia esterna external combination piece ongles / beak aussenecken zur rinnleiste angle exterieur escocia externo наружный угол
<b>AN.L.</b>	angolo listello edging tile internal corner leistenecke listel angle rentrant angolo listelo угол бордюра	<b>C4</b>	composizione 4 pezzi 4-pcs composition vierteiliges bild composition 4 pieces composición 4 piezas композиция из 4 деталей	<b>LO.C.</b>	london/copribordo london/edge cover london/randfliese london/moulure de finition london/cubreborde лондон/угловая бортовая плитка	<b>SP.EST.</b>	spigolo esterno external corner aussenecke angle exterieur esquina externo наружный угол	<b>Z.</b>	zoccolo round top hohlkehl sockel plinthe a gorge zócalo плинтус
<b>BT.</b>	battiscopa skirting sockel plinthe rodapie плинтус простой	<b>E.ELLE</b>	elemento ad elle L-tile schenkelplatte élément en L elemento en L Г-образный элемент	<b>MT.C.</b>	matita copribordo edging pencil tore randleiste moldura cubrecantos бордюр-карандаш	<b>SP.LO.</b>	spigolo london london corner london aussenecken london angle sortant esquina london наружный угол лондон		
<b>BT.B.C.</b>	battiscopa becco civetta coved skirting tile sockelleiste mit halbrundstab plinthe à bord rond rodapié canto romo плинтус с закругленным краем	<b>F.</b>	fascia border tile bordüre frise decoree senefa полоса	<b>P.</b>	piede stop and coin aussenecken zur rinnleiste angle sortant pala de elefante подошва	<b>SP.S.</b>	spigolo sigaro cigar tile external corner sigaro-aussenecken cigare angle sortant esquina sigaro наружный угол сигары		

NOTE: GLI SPESSORI SONO ESPRESSI IN mm  
NOTE: THICKNESS EXPRESSED IN mm  
REMARQUE: EPAISSEURS EXPRIMEES EN mm  
ANMERKUNG: DIE STÄRKEN SIND IN mm AUSGEDRÜCKT  
NOTA: LOS ESPESORES SE INDICAN EN mm  
ПРИМЕЧАНИЕ: ТОЛЩИНА ВЫРАЖЕНА В мм



KEY TO SYMBOLS **SIMBOLOGIA**

symbole - symbologie - simbología - символы



pavimento matt  
matt flooring  
matter Bodenbelag  
revêtement de sol mat  
pavimento mate  
матовая напольная плитка



rivestimento matt  
matt wall tiling  
matte Wandverkleidung  
revêtement de mur mat  
revestimiento mate  
матовая облицовочная плитка



pavimento semimatt  
semimatt flooring  
halbmatter Bodenbelag  
revêtement de sol semi-mat  
pavimento semimate  
полуматовая напольная плитка



rivestimento semimatt  
semimatt wall tiling  
halbmatte Wandverkleidung  
revêtement de mur semi-mat  
revestimiento semimate  
полуматовая облицовочная плитка



pavimento lucido  
glossy flooring  
glänzender Bodenbelag  
revêtement de mur lustré  
pavimento brillante  
блестящая напольная плитка



rivestimento lucido  
glossy wall tiling  
glänzende Wandverkleidung  
revêtement de mur lustré  
revestimiento brillante  
блестящая облицовочная плитка



spessore sottile  
slim thickness  
Geringe Stärke  
épaisseur fine  
espesor fino  
тонкий



ingelivo/gelivo  
frostproof/non-frostproof  
frostbeständig/frostempfindlich  
ingélif/gélif  
resistente a la helada/disgregable por helada  
морозостойкий/неморозостойкий



rivestimenti in pasta bianca/rossa  
white/red body wall tiles  
wandfliesen aus weissem ton/rotem Scherben  
revêtements en pâte blanche/rouge  
revestimiento en pasta blanca/roja  
облицовка из белой/красной плитки для стен на красной основе



rivestimenti su supporto vetroso  
mosaic glass wall tiles  
glasmosaik-Wandfliesen  
mosaïques en pâte de verre  
mosaicos en pasta vítrea  
облицовочная плитка на стекловидной основе



pezzi  
pieces  
stücke  
pièces  
piezas  
штуки



scatole  
box  
karton  
boite  
caja  
коробки



m<sup>2</sup>  
sq.mt.  
qm  
m<sup>2</sup>  
m<sup>2</sup>  
m<sup>2</sup>



peso  
weight  
gewicht  
poids  
kg  
вес



spessore  
thickness  
stärke  
épaisseur  
espesor  
толщина

**HIGH PERFORMANCE**

prodotto ad alto contenuto tecnico  
product with a high technical content  
produkt mit hohem technischem Wert  
produit à contenu technologique élevé  
producto de alto contenido técnico  
высокотехнологический продукт



ISO 10545-6  
UNI EN 14411-G

resistenza all'abrasione profonda  
resistance to deep abrasion  
tiefenabriebfestigkeit  
résistance à l'abrasion profonde  
resistencia a la abrasión profunda  
устойчивость к глубокому истиранию



DIN 51130  
BGR 181



DIN 51097  
GU 26.17



ENV 12633  
BOE N°74 DEL 2006



BSEN 13036-4: 2011



D.M. N°236 14/6/1989



ANSI 137.1: 8012



ANSI 137.1: 2008

resistenza allo scivolamento  
skid resistance  
rutschfestigkeit  
résistance à la glissance  
resistencia al deslizamiento  
сопротивление скольжению

I PTV dichiarati a catalogo sono determinati utilizzando lo slider 96.  
The PTVs stated in the catalogue are determined using slider 96.  
Die im Katalog ausgewiesenen PTV-Werte wurden unter Verwendung des Gleiters 96 ermittelt.  
Les PTV déclarés dans le catalogue ont été déterminés avec le patin 96.  
Los PTV declarados en el catálogo se han determinado utilizando la zapata de dureza 96.  
Заявленные в каталоге значения маянкового теста (PTV) определяются с использованием слайдера 96.

•

Consigliato per la posa a rivestimento di interni, si suggerisce la posa con colle poliuretatiche ed epossidiche. In caso di utilizzo di colle cementizie, si raccomanda l'accortezza di pulire immediatamente l'eccesso di colla sulla parte in vista con acqua ed una spugna morbida. È sconsigliato l'uso del listello in zone salmastre a forte concentrazione di atmosfere saline perchè soggetto a formazione di ruggine. Consigliamo anche di non utilizzare i listelli in condizioni di immersione continuativa. / Recommended for interior coverings, laid using polyurethane and epoxy adhesives. If using cement-based adhesives, clean off the excess glue immediately from the visible areas with a soft sponge. Listel tiles and inserts should not be used in brackish areas with a strong concentration of saline atmospheres (beaches, ports, etc), because they are subject to rust formation (pitting corrosion). We also recommend avoiding the use of the listel tiles in conditions where they are continually immersed in water. / Für die Verkleidung von Innenbereichen und bei Verwendung von Polyurethan- und Epoxyd-Klebern empfohlen. Im Falle einer Verwendung von zementklebern empfehlen wir, den überstehenden Kleber auf den sichtbaren Bereichen sofort mit Wasser und einem weichen Schwamm zu entfernen. Die Verwendung der Leiste/des Einlegers in Brackwassergebieten mit einer hohen Salzkonzentration in der Luft ist nicht empfehlenswert weil sich Rost bilden kann. Wir empfehlen die Leisten auch nicht in Bereichen zu verwenden, die ständig unter Wasser liegen. / Conseillé pour une pose en intérieur, il est préconisé d'employer des colles polyuréthaniques et époxy. En cas d'utilisation d'adhésifs à base de ciment, il est recommandé de bien nettoyer tout de suite l'excès de colle sur la partie en vue avec une éponge douce imbibée d'eau. L'utilisation du listel est déconseillée dans les endroits saumâtres à forte concentration d'atmosphères salines car il est sujet à la formation de rouille. En outre, nous conseillons de ne pas utiliser les listels dans des endroits immergés en permanence. / Está aconsejado para la colocación de revestimientos de interiores, recomendándose la colocación con adhesivos de poliuretano y epoxi. En caso de utilización de cemento-cola, se recomienda limpiar inmediatamente el exceso de adhesivo de la parte visible utilizando agua y una esponja blanda. Se desaconseja el uso del listelo/taco decorativo en zonas salobres con una fuerte concentración de atmósferas salinas, al estar sujeto a la formación de corrosión por picaduras. Se aconseja también no utilizar los listelos en condiciones de inmersión continua. / Рекомендуется для облицовки стен в помещениях; укладка выполняется на полиуретановый и эпоксидный клей. В случае применения клея на цементной основе следует немедленно удалять его избытки с видимых участков с помощью мягкой смоченной в воде губкой. Не рекомендуется применение бордюра/уголка в солесодержащих средах с большой концентрацией соли в атмосфере, поскольку он подвержен образованию ржавчины. Также рекомендуем не использовать бордюры/ступени в условиях постоянного погружения в воду.

**COLOUR VARIATIONS VARIAZIONI CROMATICHE**  
farbvariationen - variations chromatiques - variaciones cromáticas - варианты оттенка



**ASPETTO UNIFORME / UNIFORM APPEARANCE / EINHEITLICHES AUSSEHEN / ASPECT UNIFORME / ASPECTO UNIFORME / ОДНОРОДНЫЙ ВИД**

Colore uniforme, le differenze tra piastrelle della stessa produzione sono minime. / Uniform colour with only minimal differences between tiles in the same production run. / Einheitliche Farbe; die Unterschiede zwischen den Fliesen der gleichen Produktionscharge sind minimal. / Couleur uniforme, différences minimales entre les carreaux du même lot de production. / Color uniforme, las diferencias entre los azulejos de un mismo lote de producción son mínimas. / Однородный цвет, разница между плитками одной партии минимальна.



**LIEVE VARIAZIONE / SLIGHT VARIATION / GERINGE VARIATION / VARIATION LÉGÈRE / VARIACIÓN LEVE / ЛЕГКИЕ ОТЛИЧИЯ**

Apprezzabili differenze nell'aspetto di superficie e grafica all'interno della stessa produzione. / Clearly distinguishable differences in texture and pattern within the same production run. / Auffällige Unterschiede in Aussehen und Struktur innerhalb der gleichen Produktionscharge. / Différences visibles au niveau de l'aspect et de la fantaisie entre les carreaux du même lot de production. / Diferencias visibles en el aspecto de la superficie y los motivos dentro de un mismo lote de producción. / Заметные отличия вида поверхности и графики в одной и той же партии.



**MODERATA VARIAZIONE / MODERATE VARIATION / MÄSSIGE VARIATION / VARIATION MODÉRÉE / VARIACIÓN MODERADA / СРЕДНИЕ ОТЛИЧИЯ**

Significativa variazione di aspetto superficiale, grafica e colore da piastrella a piastrella e all'interno della stessa piastrella. Si consiglia di visionare la gamma cromatica prima della selezione del materiale. / Significant variation in texture, pattern and colour from tile to tile within the same production run. The colour range should be viewed before selecting the material. / Bedeutende Variation in Aussehen, Struktur und Farbe von Fliese zu Fliese und in ein und derselben Fliese. Es wird empfohlen, das Farbsortiment vor der Auswahl des Materials zu prüfen. / Variation significative au niveau de l'aspect, de la fantaisie et de la couleur entre les carreaux et au sein d'un même carreau. Il est recommandé de consulter la gamme des couleurs avant de sélectionner le matériel. / Variación considerable en el aspecto superficial, los motivos y el color entre un azulejo y otro y dentro del propio azulejo. Es aconsejable visualizar la gama cromática antes de seleccionar el material. / Значительные отличия вида поверхности, графики и цвета у разных плиток и на одной и той же плитке. Перед отбором материала рекомендуется посмотреть цветовую гамму.



**SOSTANZIALE-RANDOM / SUBSTANTIAL-RANDOM VARIATION / STARK-ZUFÄLLIG / VARIATION IMPORTANTE-RANDOM / SUSTANCIAL/ALEATORIA / СУЩЕСТВЕННЫЕ ОТЛИЧИЯ-ПРОИЗВОЛЬНЫЙ ЦВЕТ**

Variazioni irregolari da piastrella a piastrella. Una piastrella può differire totalmente nell'aspetto superficiale e colore da un'altra. Si consiglia di visionare la gamma cromatica prima della selezione del materiale. / Random differences from tile to tile. One tile may have totally different texture and colour from another. The colour range should be viewed before selecting the material. / Wesentliche Variationen von Fliese zu Fliese. Eine Fliese kann sich in Aussehen und Farbe komplett von einer anderen unterscheiden. Es wird empfohlen, das Farbsortiment vor der Auswahl des Materials zu prüfen. / Variations irrégulières entre les carreaux. L'aspect et la couleur peuvent être complètement différents d'un carreau à l'autre. Il est recommandé de consulter la gamme des couleurs avant de sélectionner le matériel. / Variaciones irregulares entre un azulejo y otro. Un azulejo puede ser completamente diferente de otro en el aspecto superficial y el color. Es aconsejable visualizar la gama cromática antes de seleccionar el material. / Неоднородные изменения на разных плитках. Каждая плитка может полностью отличаться по виду поверхности и цвету от другой. Перед отбором материала рекомендуется посмотреть цветовую гамму.

Per le collezioni con grado di stonizzazione V2, V3 e V4 si raccomanda di scegliere le piastrelle da più scatole, in modo da garantire una maggiore varietà ed alternanza cromatica e grafica, ottenendo così un maggior effetto naturale. / For collections with V2, V3 and V4 shade variation, tiles should be taken from more than one box at a time to guarantee a greater variety and alternation of colouring and patterns, for a more natural effect. / Für die Kollektionen mit den Schattierungen V2, V3 und V4 wird empfohlen, die Fliesen aus verschiedenen Kartons zu mischen, um eine größere Farben- und Strukturvielfalt zu erzielen und die natürliche Wirkung zu verstärken. / Pour les collections présentant un degré de variation de nuance V2, V3 et V4, il est recommandé de choisir des carreaux provenant de différentes boîtes, afin de garantir plus de variété et une meilleure alternance des motifs et des couleurs, ce qui permet ainsi d'obtenir un effet naturel plus prononcé. / En las colecciones que presenten grados de destonificación V2, V3 y V4, se recomienda tomar azulejos de varias cajas para garantizar una mayor variedad y alternancia cromática y gráfica y así conseguir un mayor efecto natural. / Для коллекций с отличием тона V2, V3 и V4 рекомендуется выбирать плитку из нескольких коробок, чтобы обеспечить наибольшее разнообразие и чередование цветов и графики, получая тем самым наиболее выраженный натуральный эффект.

**gradoni e scalini / large and small steps / stufenplatten und treppenplatten / marches larges et marches / escalones y peldaños / ступени с загибом и без**

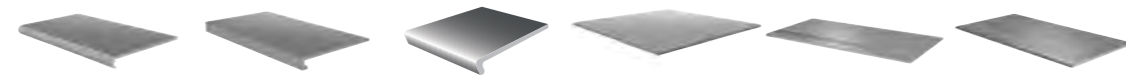

**GRADONE LINEARE CON TORELLO APPLICATO**  
straight step with added bullnose  
stufenplatte gerade mit angesetzter florentiner kante  
large marche droite avec bord arrondi  
escalón lineal con canto redondeado aplicado  
загибающаяся линейная ступень с наложенным внешним углом

**GRADONE LINEARE TAGLIATO ED ASSEMBLATO**  
two-piece straight step  
stufenplatte gerade geschnitten und zusammengesetzt  
large marche droite coupée et assemblée  
escalón lineal cortado y montado  
собранная загибающаяся линейная ступень со срезом

**GRADONE LINEARE MONOLITICO**  
one-piece straight step-tread tile  
stufenplatte gerade, einteilig  
nez de marche monolithique  
peldaño ingletado lineal monolitico  
линейная монолитная ступень

**SCALINO LINEARE TAGLIATO ED ASSEMBLATO CON MATERIALE RIPORTATO SUL FRONTE**  
two-piece straight step with added material on front  
treppenauftritt gerade, geschnitten und zusammengesetzt, mit frontseitigem Materialaufsatz  
marche linéaire coupée et assemblée avec du matériau reproduit sur le devant  
peldaño lineal cortado y montado con material llevado a la parte frontal  
собранная загибающаяся линейная ступень со срезом и с материалом на передней стороне

**SCALINO BECCO CIVETTA SMALTATO CON INSERIMENTO RIGHE IN ACCIAIO**  
glazed covered edge step with steel strips  
treppenplatte mit glasierter viertelstabskante und eingesetzten stahlprofilen  
large marche avec bord rond émaillé et bandes en acier  
peldaño de canto romo esmaltado con inserción de rayas de acero  
ступень с глазурованным закругленным краем с встроеными стальными полосами

**SCALINO BECCO CIVETTA SMALTATO CON RIGHE INCISE**  
glazed covered edge step with sunken grooves  
treppenplatte mit glasierter viertelstabskante und eingefrästen rillen  
large marche avec bord rond émaillé et bandes gravées  
peldaño de canto romo esmaltado con rayas grabadas  
ступень с закругленным глазурованным краем с нарезными полосами

A

B

C

D

E

F

Concept	
Concept XT20	
Creek	
Emilia	
Galassia	
Epoca	
Rewind	
Royale	
Realstone_Cardoso	
Realstone_Jerusalem	
Realstone_Lunar	
Realstone_Quarzite	
Realstone_Navigli	
Realstone_Rain	
Realstone_Slate	
Replace	
Re_Solution	
Rock Ground	
Season	
Stoneway_Ardesia	
Stoneway_Barge Antica	
Stoneway_Barge Antica XT20	
Stoneway_Porfido	
Stoneway_Porfido XT20	
Woodliving	
Woodliving XT20	
Woodside	
Woodspace	
Woodtale	
Woodtale XT20	

**scalini / small steps / treppenplatten / marches / peldaños / загибом и без**

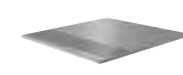

**SCALINO CON RIGHE IN CORINDONE**  
step tile with carborundum strips  
treppenplatte mit aufgesetzten Korundprofilen  
large marche avec bandes en corindon  
peldaño con rayas de corindón  
ступень с полосами из корунда

**angolari / corners / eckplatten / pièces d'angle / angulares / угловые элементы**



**ANGOLARE TAGLIATO ED ASSEMBLATO SX/DX**  
l/r two-piece corner eckplatte geschnitten und zusammengesetzt li./re.  
pièce d'angle coupée et assemblée gauche/droite  
angular cortado y montado  
izqda/dcha  
собранный угловой элемент лев/прав со срезом

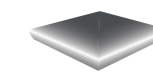

**ANGOLARE MONOLITICO**  
one-piece corner tile eckstück, einteilig  
pièce d'angle monolithique  
pieza angular monolitica  
монолитный угол

**elementi ad elle / L-tiles / schenkelplatten / éléments en L / elementos en forma de "L" / Г-образные элементы**



**ELEMENTO AD ELLE MONOLITICO PIEGATO**  
one-piece bent L-tile schenkelplatte einteilig, gebogen  
élément en L monolithique cintré  
elemento en forma de "L" monolítico doblado  
МОНОЛИТИЧНЫЙ ГНУТЫЙ Г-ОБРАЗНЫЙ ЭЛЕМЕНТ

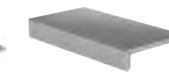

**ELEMENTO AD ELLE TAGLIATO ED ASSEMBLATO**  
two-piece L-tile schenkelplatte geschnitten und zusammengesetzt  
élément en L coupé et assemblé  
elemento en forma de "L" cortado y montado  
собранный Г-образный элемент со срезом

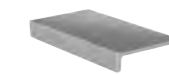

**ELEMENTO AD ELLE MONOLITICO PRESSATO**  
one-piece pressed L-tile schenkelplatte einteilig, gepresst  
élément en L monolithique pressé  
elemento en forma de "L" monolítico prensado  
МОНОЛИТИЧНЫЙ ПРЕССОВАННЫЙ ЭЛЕМЕНТ

G

H

I

L

M

N

Concept	
Concept XT20	
Creek	
Emilia	
Galassia	
Epoca	
Rewind	
Royale	
Realstone_Cardoso	
Realstone_Jerusalem	
Realstone_Lunar	
Realstone_Quarzite	
Realstone_Navigli	
Realstone_Rain	
Realstone_Slate	
Replace	
Re_Solution	
Rock Ground	
Season	
Stoneway_Ardesia	
Stoneway_Barge Antica	
Stoneway_Barge Antica XT20	
Stoneway_Porfido	
Stoneway_Porfido XT20	
Woodliving	
Woodliving XT20	
Woodside	
Woodspace	
Woodtale	
Woodtale XT20	

**GRADONI E SCALINI**

large and small steps / stufenplatten und treppenplatten / marches larges et marches / escalones y peldaños / ступени с загибом и без

**A**

**gradone lineare con torelo applicato** / straight step with added bullnose / stufenplatte gerade mit angesetzter florentiner kante / large marche droite avec bord arrondi / escalón lineal con canto redondeado aplicado / загибающаяся линейная ступень с наложенным внешним углом

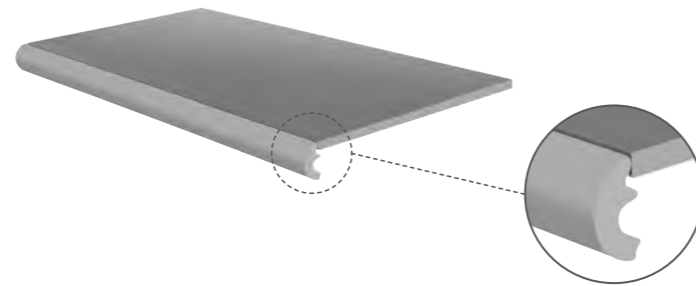
**B**

**gradone lineare tagliato ed assemblato** / two-piece straight step / stufenplatte gerade geschnitten und zusammengesetzt / large marche droite coupée et assemblée / escalón lineal cortado y montado / собранная загибающаяся линейная ступень со срезом

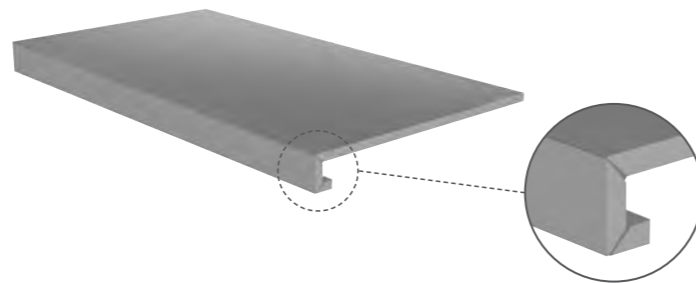
**C**

**gradone lineare monolitico** / one-piece straight step-tread tile / stufenplatte gerade, einteilig / nez de marche monolithique / peldaño ingletado lineal monolítico / линейная монолитная ступень

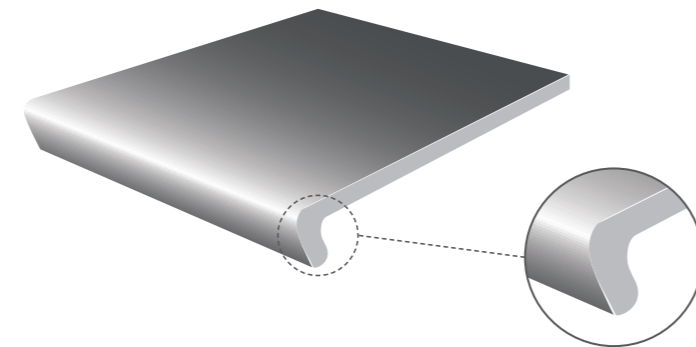
**D**

**scalino lineare tagliato ed assemblato con materiale riportato sul fronte** / two-piece straight step with added material on front / treppenauftritt gerade, geschnitten und zusammengesetzt, mit frontseitigem Materialaufsatz / marche linéaire coupée et assemblée avec du matériau reproduit sur le devant / peldaño lineal cortado y montado con material llevado a la parte frontal / собранная загибающаяся линейная ступень со срезом и с материалом на передней стороне

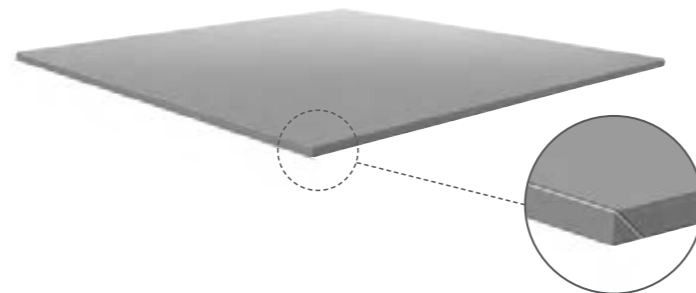
**E**

**scalino becco civetta smaltato con inserimento righe in acciaio** / glazed covered edge step with steel strips / treppenplatte mit glasierter viertelstabskante und eingesetzten stahlprofilen / large marche avec bord rond émaillé et bandes en acier / peldaño de canto romo esmaltado con inserción de rayas de acero / ступень с глазурованным закругленным краем с встроенными стальными полосами

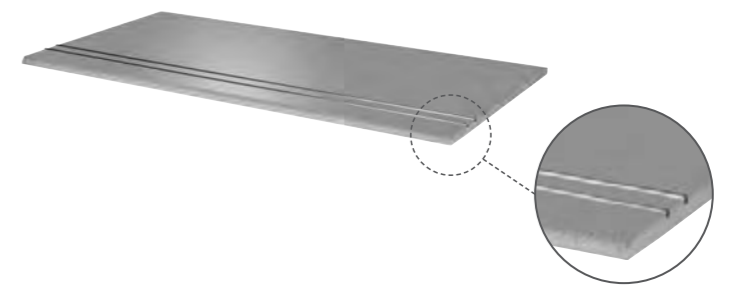
**F**

**scalino becco civetta smaltato con righe incise** / glazed covered edge step with sunken grooves / treppenplatte mit glasierter viertelstabskante und eingefrästen rillen / large marche avec bord rond émaillé et bandes gravées / peldaño de canto romo esmaltado con rayas grabadas / ступень с закругленным глазурованным краем с нарезными полосами

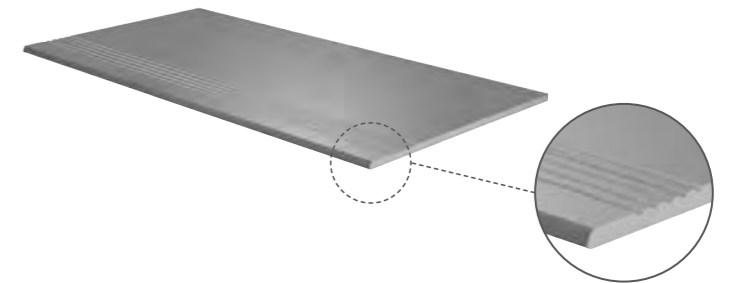
**G**

**scalino con righe in corindone** / step tile with carborundum strips / treppenplatte mit aufgesetzten Korundprofilen / large marche avec bandes en corindon / peldaño con rayas de corindón / ступень с полосами из корунда

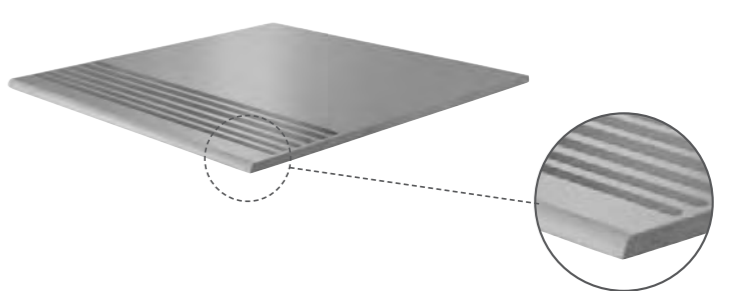

**ANGOLARI**

corners / eckplatten / pièces d'angle / angulares / угловые элементы

**H**

**angolare tagliato ed assemblato SX** / L two-piece corner /  
Eckplatte geschnitten und zusammengesetzt li. / Pièce d'angle  
coupée et assemblée Gauche / Angular cortado y montado izqda. /  
Собранный угловой элемент лев. со срезом

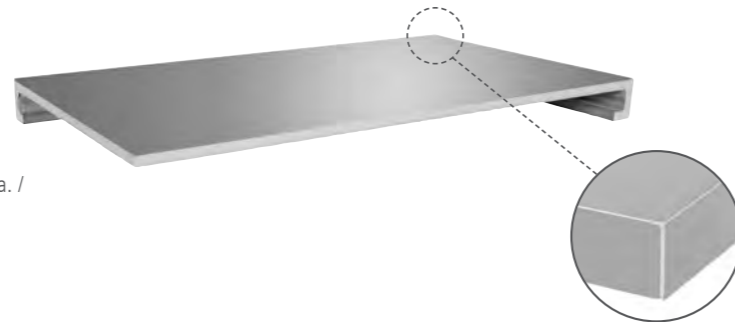

**angolare tagliato ed assemblato DX** / R two-piece corner /  
Eckplatte geschnitten und zusammengesetzt re. / Pièce d'angle  
coupée et assemblée Droite / Angular cortado y montado dcha. /  
Собранный угловой элемент прав. со срезом

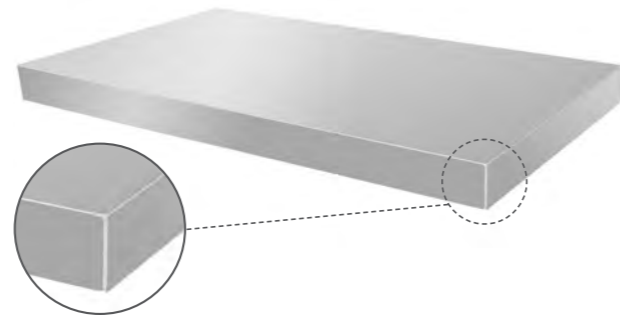
**I**

**angolare monolitico** / one-piece corner tile / eckstück, ein-  
teilig / pièce d'angle monolithique / pieza angular monolítica /  
монолитный угол

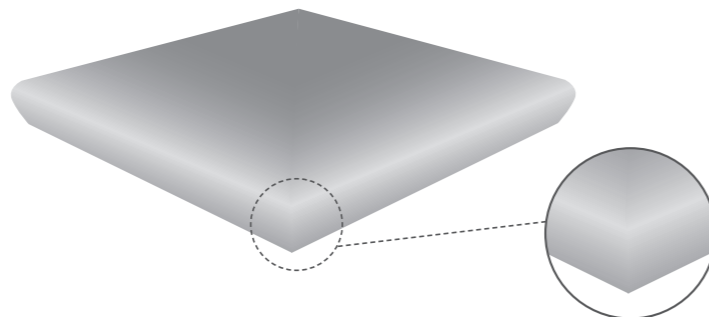
**ELEMENTI AD ELLE**

elementi ad elle / L-tiles / schenkelplatten / éléments en L / elementos en forma de "L" / Г-образные элементы

**L**

**elemento ad elle monolitico piegato** / one-piece bent L-tile /  
schenkelplatte einteilig, gebogen / élément en L monolithique  
cintré / elemento en forma de "L" monolítico doblado /  
монолитный гнутый Г-образный элемент

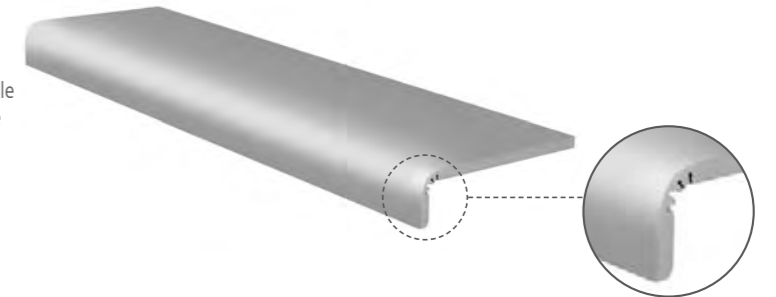
**M**

**elemento ad elle tagliato ed assemblato** / two-piece L-tile /  
schenkelplatte geschnitten und zusammengesetzt / élément en L  
coupé et assemblé / elemento en forma de "L" cortado y montado /  
собранный Г-образный элемент со срезом

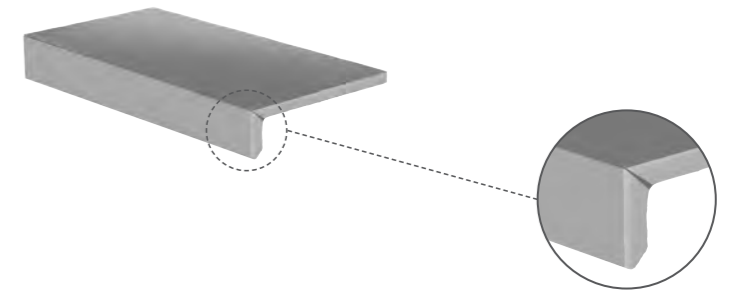
**N**

**elemento ad elle monolitico pressato** / one-piece pressed  
L-tile / schenkelplatte einteilig, gepresst / élément en L monoli-  
thique pressé / elemento en forma de "L" monolítico prensado /  
монолитный прессованный элемент

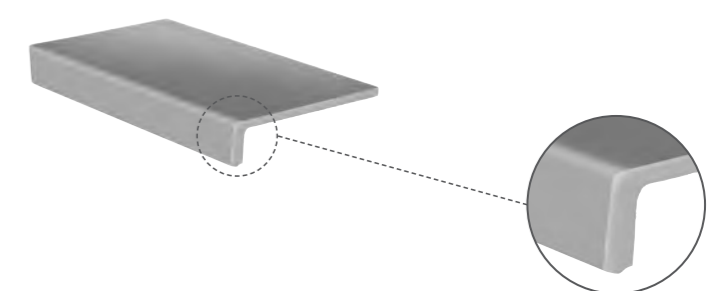

**D**

Materiali consigliati solo per bagni e camere da letto di abitazioni; ogni abrasione deve essere evitata. / Tiles suitable only for bathrooms and bedrooms; any type of abrasion must be avoided. / Nur für Bäder und Schlafzimmer des Wohnbereichs empfohlen; jeder Abrieb muss vermieden werden. / Carreaux conseillés uniquement pour salles de bains et chambres à coucher; éviter tout type d'abrasion. / Materiales aconsejados solamente para baños y dormitorios de viviendas; se debe evitar toda abrasión. / Материалы рекомендуются только для ванных комнат и спален жилых помещений. Следует избегать какого бы то ни было абразивного воздействия.

**G**

Materiali consigliati per locali sottoposti a sollecitazioni all'abrasione medio pesanti come: case individuali, commerciale leggero. / Materials recommended for premises with medium-heavy abrasion levels, such as: detached homes, light-traffic commercial premises / Empfohlen für Räume mit mittelschwerer Abriebbeanspruchung wie: Einfamilienhäuser, leicht beanspruchte Gewerbebereiche. / Matériaux recommandés pour des locaux soumis à des contraintes d'abrasion moyennes et fortes comme : maisons particulières, espaces commerciaux soumis à un trafic léger, etc. / Materiales recomendados para locales sometidos a esfuerzos de abrasión medio-pesados, como casas unifamiliares y locales comerciales de tráfico ligero. / Материалы рекомендованы для использования в частных домах и коммерческих помещениях, подверженных средне-сильному абразивному воздействию.

**E**

Materiali consigliati per tutti i locali di un'abitazione, con esclusione dell'ingresso e della cucina; deboli sollecitazioni all'abrasione. / Tiles suitable for all rooms of a house except the entrance hall and the kitchen; low stress abrasive wear. / Für alle Räume des Wohnbereichs empfohlen, mit Ausschluss von Dielen und Küchen; leichte Abriebbeanspruchung. / Carreaux conseillés pour toutes les pièces d'une maison, excepté le vestibule et la cuisine; abrasion sous contraintes faibles. / Materiales aconsejados para todas las habitaciones de una vivienda excluyendo el vestíbulo y la cocina; atenuada exposición a la abrasión. / Материалы рекомендованы для любых жилых помещений, кроме прихожей и кухни. Небольшое абразивное воздействие.

**H**

Materiali consigliati per sollecitazioni all'abrasione relativamente forti in ambienti anche non protetti da agenti graffianti. / Materials recommended for relatively heavy abrasion levels, also in premises not protected against abrasive substances. / Empfohlen für starke Abriebbeanspruchungen in Bereichen auch ohne Kratzschutzbehandlung. / Matériaux recommandés pour des locaux soumis à des fortes contraintes d'abrasion, même non protégés contre les agents abrasifs. / Materiales recomendados para soportar esfuerzos de abrasión relativamente intensos incluso en espacios no protegidos frente a agentes abrasivos. / Материалы рекомендованы для относительно сильного абразивного воздействия, в том числе в помещениях, не защищенных от царапающих элементов.

**F**

Materiali consigliati per qualsiasi locale di un'abitazione che non abbia collegamenti diretti con l'esterno o accessi non protetti da zerbini. Medie sollecitazioni all'abrasione. / Tiles suitable for any room of a house without direct access from the outside or access not protected by doormats. Mean stress abrasive wear. / Für alle Räume des Wohnbereichs empfohlen, zu denen man keinen direkten Zutritt von außen hat oder welche nicht durch Fußteppiche abgegrenzt sind. Mittlere Abriebbeanspruchung. / Matériaux conseillés pour toutes les pièces d'une maison qui n'a pas d'accès directs par l'extérieur ou non protégés par des paillasons. Abrasion sous contraintes moyennes. / Materiales aconsejados para cualquier habitación de una vivienda sin accesos directos desde el exterior o accesos no protegidos por felpudos. Esfuerzos medianos por abrasión. / Материалы рекомендованы для любых жилых помещений, не имеющих прямого выхода на улицу или же доступа без входных ковриков. Среднее абразивное воздействие.

**MARBLE/CONCRETE EFFECT VARIATIONS MAIORA VARIAZIONI EFFETTO MARMO/CEMENTO**  
Bildvariationen Marmor-/Betonoptik - Variations effet marbre/béton -  
Variaciones de efecto mármol o cemento - Вариации эффекта мрамора/цемента

Le immagini riportate rappresentano tutte le diverse grafiche del prodotto che vengono realizzate in successione sulla linea di produzione per ogni codice. Il codice prodotto è univoco: non è quindi possibile scegliere le grafiche e garantire la presenza di tutte le facce nella preparazione del materiale. / The images shown illustrate the different product patterns manufactured in succession on the production line for each article. Every product code is unique: therefore, it is not possible to choose the patterns or guarantee that every tile surface will be included when the material is prepared. / Les images reproduisent les différentes textures graphiques du produit, réalisées l'une à la suite de l'autre sur la ligne de production pour chaque code. Le code produit est univoque : il n'est donc pas possible de choisir les textures graphiques et de garantir la présence de toutes les variantes dans la préparation du matériau. / Die Bilder zeigen die unterschiedlichen Materialzeichnungen des Produktes, die in der Produktionslinie für jeden Code nacheinander hergestellt werden. Es handelt sich um einen einheitlichen Produktcode: Aus diesem Grund ist es nicht möglich, die Materialzeichnungen auszuwählen und bei der Vorbereitung des Materials zu gewährleisten, dass alle Oberflächen vorhanden sind. / Las imágenes presentadas muestran los diversos diseños gráficos del producto que se fabrican en serie en la línea de producción en referencia a cada código. El código del producto es unívoco: esto significa que no se pueden elegir los diseños gráficos y garantizar la presencia de todas las caras en la preparación del material. / На изображениях приводится все разнообразие графики изделий, которая выпускается на производственной линии в последовательности для каждого кода. Код изделия является единым, следовательно, нельзя выбирать графику и гарантировать наличие всех вариантов при подготовке материала.

**Stepwise**

Le piastrelle realizzate con questa nuova tecnologia sono caratterizzate da un'elevata resistenza allo scivolamento e da una superficie morbida al tatto e facile da pulire, data l'assenza di ruvidità superficiale. / The tiles produced using this new technology have a high degree of slip resistance and a surface which is soft to the touch and easy to clean, since it has no superficial roughness. / Les carreaux utilisant cette nouvelle technologie de production se distinguent par une très grande résistance à la glissance et par une surface douce au toucher et facile à nettoyer puisqu'elle ne présente aucune rugosité. / Mit dieser neuen Technologie hergestellte Fliesen zeichnen sich durch eine hohe Rutschhemmung, eine weiche Haptik und eine einfache Reinigung aufgrund der fehlenden Oberflächenrauheit aus. / Los azulejos fabricados aplicando esta nueva tecnología se caracterizan por su elevada resistencia al deslizamiento y por presentar una superficie suave al tacto y fácil de limpiar, dada la nula aspereza de su superficie. / Произведенная по этой новой технологии плитка обладает высокой стойкостью к скольжению и мягкой на ощупь, легко очищаемой поверхностью, что обеспечивается отсутствием шероховатости на поверхности.



L'Azienda assolve agli obblighi sulla marcatura CE rendendo disponibili le informazioni sul proprio sito web: [www.ragno.it](http://www.ragno.it)

Conformément aux dispositions en matière de marquage CE, l'entreprise publie les informations requises sur son site Web: [www.ragno.it](http://www.ragno.it)



La certificazione francese QB UPEC offre all'utente una garanzia: assicura che i prodotti consegnati, recanti i loghi QB e UPEC, siano conformi a quanto previsto dalla norma NF EN 14411 secondo le presenti regole di certificazione e che tali prodotti possiedano le caratteristiche d'uso definite nel disciplinare CSTB «Specifiche tecniche per la classificazione UPEC dei rivestimenti ceramici per pavimenti». Le quattro lettere indicano rispettivamente:  
U: resistenza all'usura da calpestio  
P: resistenza meccanica agli spostamenti di oggetti mobili e fissi  
E: comportamento in presenza di acqua  
C: resistenza agli agenti chimici correnti  
La lista completa e aggiornata dei prodotti certificati è visionabile sul sito [www.cstb.fr](http://www.cstb.fr).  
Per qualsiasi ulteriore informazione contattare Marazzi Group.

La certification française QB UPEC représente une garantie pour l'utilisateur. En effet, elle atteste la conformité des produits marqués QB UPEC aux spécifications de la norme NF EN 14411 selon les présentes règles de certification. Elle garantit également que ces produits possèdent les caractéristiques d'usage établies dans le cahier du CSTB « Revêtements de sol céramiques - Spécifications techniques pour le classement UPEC ». Les quatre lettres indiquent respectivement :  
U : Usure à la marche  
P : Résistance mécanique au déplacement d'objets mobiles et fixes  
E : Comportement à l'eau  
C : Tenue aux agents chimiques ordinaires  
La liste complète et à jour des produits certifiés peut être consultée sur le site [www.cstb.fr](http://www.cstb.fr).  
Pour tout renseignement complémentaire, veuillez contacter Marazzi Group.



Idoneità delle piastrelle ceramiche alla posa su piedini.

Aptitude des carreaux céramiques à une mise en oeuvre sur plots.

The Company fulfils its CE marking obligations through publication of all relative information on its website: [www.ragno.it](http://www.ragno.it)

La empresa cumple con las obligaciones del sello CE ofreciendo información en su página web: [www.ragno.it](http://www.ragno.it)

French QB UPEC certification provides the user with a quality guarantee: it confirms that the products delivered, marked with the QB and UPEC logos, comply with the prerequisites of the NF EN 14411 standard in accordance with the current certification rules and that they have the performance characteristics specified in the CSTB (Centre Scientifique et Technique du Bâtiment - Scientific and Technical Centre for Building) "Technical Specifications for the UPEC Classification of Ceramic Floor Coverings". The four letters refer to:  
U: resistance to foot traffic wear  
P: mechanical resistance to the shifting of movable and fixed objects  
E: resistance to water  
C: resistance to commonly used chemicals  
The full, up-to-date list of certified products can be viewed at [www.cstb.fr](http://www.cstb.fr).  
Please contact the Marazzi Group for any further information.

La certificación francesa QB UPEC le ofrece al usuario la garantía de que los productos entregados que lleven los logotipos QB y UPEC resultan conformes con lo previsto por la norma NF EN 14411 de acuerdo con las presentes reglas de certificación y que tales productos poseen las características de uso referidas en el reglamento del CSTB (Centro Científico y Técnico de la Construcción de Francia) denominado «Especificaciones técnicas para la clasificación UPEC de revestimientos cerámicos para pavimentos». Respectivamente, las cuatro letras indican:  
U: resistencia a la abrasión provocada por el tránsito peatonal  
P: resistencia mecánica al desplazamiento de objetos móviles y fijos  
E: comportamiento en presencia de agua  
C: resistencia a los productos químicos de uso común.  
La lista completa y actualizada de los productos certificados se puede consultar accediendo al sitio web [www.cstb.fr](http://www.cstb.fr). Para más información pueden ponerse en contacto con Marazzi Group.

Suitability of ceramic tiles for installation on pedestals.

Idoneidad de las baldosas cerámicas para la colocación sobre soportes.

Die Firma erfüllt die Verpflichtungen für das CE-Kennzeichnung und stellt die Informationen auf der eigenen Internetseite [www.ragno.it](http://www.ragno.it) bereit

Компания выполняет свои обязанности по маркировке CE, предоставляя информацию на ее сайте интернете: [www.ragno.it](http://www.ragno.it)

Die französische UPEC Zertifizierung garantiert dem Endkunden, dass die mit dem Logo QB-UPEC gekennzeichneten Artikel den Bestimmungen der Norm NF EN 14411 gemäß den Zertifizierungsregelungen entsprechen und die Gebrauchseigenschaften besitzen, die vom Merkblatt des CSTB (Centre Scientifique et Technique du Bâtiment - Wissenschaftliches und technisches Zentrum für Bauwesen) „Technische Vorschriften für die UPEC Klassifizierung von keramischen Bodenbelägen“ festgelegt sind.  
Die vier Buchstaben bezeichnen jeweils:  
U: Trittschallabnutzung  
P: Eindrucksuren durch Mobiliar und sonstige fest installierte oder mobile Einrichtungen (Objekte)  
E: Verhalten gegenüber Wasser  
C: Verhalten gegenüber Chemikalien  
Die komplette und aktualisierte Liste der zertifizierten Produkte ist im Internet auf [www.cstb.fr](http://www.cstb.fr) einsehbar.  
Für ausführliche Informationen kontaktieren Sie bitte die Marazzi Group.

Французский сертификат QB UPEC предлагает клиенту следующую гарантию: подтверждает, что поставленная продукция, имеющая логотип QB и UPEC, соответствует нормам NF EN 14411 по существующим правилам сертификации, и что данная продукция обладает характеристиками по эксплуатации, определенными в правилах CSTB "Технические спецификации для классификации UPEC керамических материалов для настила полов".  
Четыре буквы сокращения обозначают:  
U: износостойкость при хождении  
P: механическая стойкость к передвижению передвижных и неподвижных предметов  
E: поведение при наличии воды  
C: стойкость к воздействию химических веществ  
Полный обновленный перечень сертифицированных продуктов приводится на сайте [www.cstb.fr](http://www.cstb.fr). За любой другой информацией обращайтесь в Marazzi Group.

Eignung der keramischen Fliesen zur Verlegung auf Stelzlägern.

Пригодность керамической плитки для укладки на опоры.

## CERTIFICATIONS CERTIFICAZIONI

zertifizierungen - certifications - certificaciones - сертификации



Ragno è un brand di Marazzi Group S.r.l. che è membro del Green Building Council Italia, associazione che promuove la cultura dell'edilizia sostenibile energeticamente efficiente, rispettosa dell'ambiente contribuendo a migliorare la qualità della vita dei cittadini attraverso lo standard di certificazione LEED®.

Ragno est une marque du Groupe Marazzi S.r.l. membre du GBC Italia (Green Building Council Italia) qui est une association dont l'objectif est de favoriser et accélérer la diffusion d'une culture du bâtiment durable énergétiquement efficace, respectueuse de l'environnement, en sensibilisant l'opinion publique quant à son impact sur la qualité de la vie des citoyens, à travers du système de certification LEED®.

### Leed® Credit

La certificazione volontaria LEED® (Leadership in Energy and Environmental Design) è il protocollo più diffuso a livello internazionale per la bioedilizia e la progettazione sostenibile promosso da U.S. Green Building Council. Il sistema di rating LEED® si struttura in 9 categorie, ciascuna delle quali è organizzata in prerequisiti obbligatori e crediti determinati dalle caratteristiche del progetto. Tutti i prodotti in ceramica e in gres porcellanato Ragno, grazie alla qualità ecologica dell'intero ciclo industriale di produzione, contribuiscono all'ottenimento dei crediti LEED® degli edifici, in particolare, per le aree tematiche relative a Materiali e Risorse (MR), Sito Sostenibile (SS) e Qualità Ambientale Interna (EQ).

### Crédit Leed®

Initiée par l'US Green Building Council, la certification volontaire LEED® (Leadership in Energy and Environmental Design) est le référentiel le plus divulgué à l'international pour la bioconstruction et pour la construction durable. Le système de rating LEED® est divisé en neuf catégories intégrant chacune des critères obligatoires et des crédits en fonction des caractéristiques du projet. En raison de la qualité écologique du cycle industriel, tous les produits en céramique et grès cérame Ragno contribuent à l'obtention des crédits LEED®, et notamment dans les catégories Matériaux et Ressources (MR), Aménagement écologique des sites (SS) et Qualité environnementale de l'air intérieur (EQ).

Ragno is a brand of Marazzi Group S.r.l. which is a member of the Green Building Council Italia, an association that promotes sustainable energy-efficient building practices, which are environmentally friendly and help improve the quality of life through LEED® certification standards.

Ragno es una marca de Marazzi Group S.r.l. que es miembro del Green Building Council Italia, asociación que promueve la cultura de la construcción sostenible energéticamente eficiente, respetuosa con el medio ambiente, contribuyendo a mejorar la calidad de vida de los ciudadanos a través del estándar de certificación LEED®.

### Leed® Credit

Voluntary LEED® (Leadership in Energy and Environmental Design) certification is the most widespread international protocol for green building and sustainable architecture promoted by the U.S. Green Building Council. The LEED® rating system is structured into 9 categories, each of which is organized into mandatory prerequisites and credits determined by the characteristics of the project. Thanks to the environmental quality of the entire industrial production cycle, all Ragno's ceramic and porcelain stoneware products are eligible for LEED® credits for buildings, in particular for thematic areas related to Materials and Resources (MR), Sustainable Site (SS) and Indoor Environmental Quality (EQ).

### Crédito Leed®

La certificación voluntaria LEED® (Leadership in Energy and Environmental Design) es el protocolo más difundido a nivel internacional para la construcción ecológica y el diseño sostenible promovido por el U.S. Green Building Council. El sistema de calificación LEED® está estructurado en 9 categorías, cada una de las cuales está organizada en prerequisites obligatorios y créditos determinados por las características del proyecto. Todos los productos de cerámica y gres porcelánico Ragno, gracias a la calidad ecológica de todo el ciclo industrial de producción, contribuyen a la obtención de los créditos LEED® de los edificios, en particular, para las áreas temáticas relativas a Materiales y Recursos (MR), Sitio Sostenible (SS) y Calidad Ambiental Interior (EQ).

Ragno ist eine Marke der Marazzi Group S.r.l., die Mitglied des Green Building Council Italien ist, ein Verband, der die Kultur des nachhaltigen und energieeffizienten, umweltverträglichen Bauens fördert, indem zur Lebensqualität der Mitmenschen durch die Zertifizierung nach den LEED®-Standards beigetragen wird.

Ragno является брендом компании Marazzi Group S.r.l., которая входит в Green Building Council Italia, - ассоциацию, продвигающую культуру экоустойчивого энергосберегающего строительства, щадящего окружающую среду. Соблюдение сертификационных стандартов LEED® способствует улучшению качества жизни людей.

### Leed® Punkte

Die freiwillige Zertifizierung nach LEED® (Leadership in Energy and Environmental Design) ist der internationale populärste Standard für nachhaltiges Planen und Bauen und wurde vom U.S. Green Building Council erarbeitet. Das Checklistsensystem nach LEED® ist in neun Zertifikatsgruppen gegliedert, für die jeweils obligatorische Anforderungen und Punktebewertungen ausgehend von den Projektmerkmalen gelten. Alle Produkte aus Keramik und Feinsteinzeug von Ragno tragen aufgrund der Umweltverträglichkeit ihres gesamten Fertigungsprozesses zur Erlangung von LEED® Punkten für Gebäude bei, insbesondere bezüglich der Themenfelder Materialien und Ressourcen (MR), Nachhaltige Baugelände (SS) und Komfort und Raumqualität (EQ).

### Кредиты Leed®

Добровольная сертификация LEED® (Leadership in Energy and Environmental Design) - это самый распространенный на международном уровне протокол для биостроительства и экологически рационального проектирования, продвигаемый U.S. Green Building Council. Система рейтинга LEED® подразделяется на 9 категорий, каждая из которых предусматривает обязательные предварительные требования и кредиты, определяемые характеристиками проекта. Благодаря экологичности полного промышленного производственного цикла вся керамическая и керамогранитная продукция Ragno способствует получению кредитов LEED® для зданий, в частности, для таких тематических разделов, как: Материалы и ресурсы (MR), Место экологического строительства (SS) и Качество среды в помещениях (EQ).



La Certificazione GREENGUARD GOLD garantisce che un prodotto soddisfi alcuni degli standard internazionali più rigorosi ed esaustivi in relazione alle basse emissioni di composti organici volatili (COV) in ambienti interni. Maggiori informazioni sono disponibili sul sito: <http://spot.ulprospector.com>

La certification GREENGUARD GOLD atteste qu'un produit est conforme à quelques-unes des normes les plus sévères et les plus complètes au monde en matière d'émissions dans l'air intérieur de composés organiques volatils (COV). De plus amples informations sont disponibles sur le site : <http://spot.ulprospector.com>

Abitare
A_Mano
Bistrot
Boom
Calce
Casablanca
Concept
Concept XT20
Contrasti
Creek
Eden
Epoca
Emilia
Escape
Fornace
Freetime
Galassia
Harmony
Imperiale
Ironstone
Jazz
Life
Maiores Marble Effect
Maiores Concrete Effect
Ottocento
Patina
Patina XT20
Realstone_Cardoso
Realstone_Cardoso XT20

### EPD (Environmental Product Declaration)

Marazzi Group ha valutato gli impatti ambientali legati ai propri prodotti lungo tutto il loro ciclo di vita, a partire dall'estrazione e lavorazione delle materie prime fino al recupero dei rifiuti di demolizione. I risultati di questa analisi LCA (life cycle assessment), condotta secondo le norme internazionali della serie ISO 14040, sono pubblicati nella dichiarazione ambientale di prodotto EPD (ISO 14025 e EN 15804) che contribuisce al raggiungimento di crediti per la certificazione LEED.

### DEP (Déclaration environnementale de produit)

Marazzi Group a évalué les impacts de ses produits sur l'environnement pendant tout leur cycle de vie, depuis l'extraction et la transformation des matières premières jusqu'à la récupération des déchets de démolition. Les résultats de cette analyse du cycle de vie (ACV), menée selon les normes internationales ISO 14040, sont publiés dans la Déclaration environnementale de produit (DEP) (selon les normes ISO 14025 et EN 15804) qui contribue à l'obtention des crédits pour la certification LEED.

GREENGUARD GOLD Certification ensures that a product has met some of the world's most rigorous and comprehensive standards for low emissions of volatile organic compounds (VOCs) into indoor air. More information is available on the site: <http://spot.ulprospector.com>

La certificación GREENGUARD GOLD garantiza que un producto cumple con algunas de las normas más estrictas y exhaustivas del mundo en materia de bajas emisiones de compuestos orgánicos volátiles (COV) al aire en espacios cerrados. Se halla a disposición información más detallada en el sitio: <http://spot.ulprospector.com>

Realstone_Jerusalem
Realstone_Jerusalem XT20
Realstone_Quarzite
Realstone_Quarzite XT20
Realstone_Lunar
Realstone_Lunar XT20
Realstone_Navigli
Realstone_Navigli XT20
Realstone_PietrAntica
Realstone_PietrAntica XT20
Realstone_Rain
Realstone_Rain XT20
Realstone_Slate
Realstone_Slate XT20
Replace
Re_Solution
Rewind
Rewind XT20
Rock Ground
Season
Sound
Stone
Stoneway_Ardesia
Stoneway_Ardesia XT20
Stoneway_Barge Antica
Stoneway_Barge Antica XT20
Stoneway_Porfido
Stoneway_Porfido XT20
Studio

### EPD (Environmental Product Declaration)

Marazzi Group has assessed its products' environmental impact throughout their life cycle, from extraction and processing of the raw materials through to the recycling of demolition spoil. The findings of this LCA (Life Cycle Assessment), performed in accordance with the ISO 14040 series international standards, have been published in the Environmental Product Declaration (ISO 14025 and EN 15804), contributing to the attainment of LEED certification credits.

### EPD (declaración ambiental de producto)

Marazzi Group ha evaluado el impacto ambiental relacionado con sus productos a lo largo de todo su ciclo de vida, desde la extracción y la transformación de las materias primas hasta la valorización de los residuos de la construcción y demolición. Los resultados de este análisis de ciclos de vida LCA (life cycle assessment), realizado de acuerdo con las normas internacionales de la serie ISO 14040, han sido publicados en la declaración ambiental de producto EPD (ISO 14025 y EN 15804) que contribuye a la obtención de los créditos para la certificación de sostenibilidad en la construcción LEED.

Die GREENGUARD GOLD-Zertifizierung bescheinigt, dass ein Produkt die weltweit strengsten und umfassendsten Obergrenzen für die Emission von flüchtigen organischen Verbindungen (VOCs) in die Innenraumluft einhält. Sie auf der Internetseite: <http://spot.ulprospector.com>

То сертификат GREENGUARD GOLD гарантирует, что продукция удовлетворяет один из наиболее строгих и всеохватывающих стандартов в мире по низкому выделению летучих органических соединений в воздухе помещений. Более подробная информация доступна на сайте: <http://spot.ulprospector.com>

Woodchalet
Woodchoice
Woodclass
Woodclassic
Woodcomfort
Woodcraft
Woodessence
Woodglam
Woodlike
Woodliving
Woodliving XT20
Woodmania
Woodmania XT20
Woodpassion
Woodplace
Woodreal
Woodshape
Woodsense
Woodsense XT20
Woodside
Woodsoft
Woodspace
Woodspace XT20
Woodspirit
Woodstory
Woodtale
Woodtale XT20

### Umwelt-Produktdeklaration (Environmental Product Declaration, EPD)

Die Marazzi Group hat die Umweltwirkung der eigenen Produkte im Verlauf ihres gesamten Lebenszyklus beurteilt, beginnend bei der Rohstoffgewinnung und -verarbeitung bis hin zur Wiederverwertung von Bauschutt. Die Ergebnisse dieser Ökobilanz (Life Cycle Assessment, LCA) nach der internationalen Normenreihe ISO 14040 wurden in der Umwelt-Produktdeklaration EPD gemäß ISO 14025 und EN 15804 veröffentlicht, die zur Zuerkennung von Punkten für die Zertifizierung nach dem Zertifizierungssystem LEED beiträgt.

### EPD (Environmental Product Declaration, Экологическая декларация продукции)

Marazzi Group оценила воздействие на окружающую среду своей продукции в течение всего ее жизненного цикла, начиная с добычи и переработки сырья и вплоть до повторной переработки строительного мусора. Результаты этого анализа LCA (оценка жизненного цикла), проведенного в соответствии с международными нормами из серии ISO 14040, опубликованы в Экологической декларации продукции EPD (ISO 14025 и EN 15804), которая способствует получению кредитов для выдачи сертификата LEED.

CERTIFICATIONS CERTIFICAZIONI

zertifizierungen - certifications - certificaciones - сертификации



Ragno ha ottenuto il marchio EU Ecolabel, marchio di qualità ecologica dell'Unione Europea, che garantisce un minor consumo energetico nei processi di produzione, minori emissioni nell'aria e nell'acqua, l'utilizzo di sostanze non pericolose per l'uomo e per l'ambiente, l'utilizzo di cave con corretta gestione ambientale, una migliore informazione al consumatore e una migliore gestione dei rifiuti. Grazie a questo marchio di eccellenza, Ragno risponde ai Criteri Minimi Ambientali (CAM) previsti dagli appalti pubblici. In occasione del convegno Emas - Ecolabel di Roma dell' 1 marzo 2006, a Marazzi Group è stato conferito dal Ministero dell'Ambiente e della Tutela del Territorio, uno speciale Award per il suo impegno e la sua attenzione all'ambiente. Il rispetto dell'ambiente rappresenta un impegno di fondamentale importanza per tutti, perché l'ambiente è la "casa di tutti". Le piastrelle o loro tagli rimasti dopo l'installazione sono rifiuti non pericolosi per l'ambiente e destinati al recupero. Devono essere conferiti con il codice rifiuto europeo CER 170103 (solo piastrelle) o CER 170107 (aggregati con altro materiale edile da demolizione) e possono essere recuperati come materiale per fondo stradale, materiale di riempimento in bonifiche, produzione di laterizi. Il cartone (CER 150101), il legno (CER 170201) e i materiali plastici (CER 170203) che costituiscono l'imballaggio delle piastrelle devono essere inviati al recupero come da raccolta differenziata. Per eventuali maggiori informazioni in merito all'installazione delle piastrelle è possibile contattare il servizio assistenza vendite Ragno. Maggiori informazioni sono disponibili sul sito del marchio Ecolabel: <http://www.ecolabel.eu>

Ragno a obtenu l'EU Ecolabel, le label écologique de l'Union européenne qui garantit la réduction de la consommation énergétique dans la fabrication, la diminution des émissions dans l'air et dans l'eau, l'emploi de substances non dangereuses pour l'homme et pour l'environnement, la gestion durable des carrières, une meilleure information du consommateur et une meilleure gestion des déchets. Avec ce label d'excellence, Ragno observe les critères environnementaux minimum (CAM) imposés par les marchés publics. À l'occasion de la conférence EMAS-Ecolabel du 1 mars 2006 à Rome, le Ministère de l'Environnement et de la Protection du Territoire italien a décerné à Marazzi Group une récompense spéciale pour son engagement et pour sa sensibilité à l'égard de l'environnement. L'environnement, c'est la « maison de tous » : son respect est donc un engagement d'importance capitale pour tout un chacun. Les carreaux ou les découpes en surplus au terme de la pose sont des déchets non dangereux pour l'environnement et destinés au recyclage. Ces déchets doivent être remis sous le code européen CED 170103 (céramiques uniquement) ou CED 170107 (mélanges avec d'autres déchets de construction et de démolition) et peuvent être réutilisés pour la réfection des chaussées, pour le remplissage des ouvrages d'assainissement, pour la fabrication de briques. Le carton (CED 150101), le bois (CED 170201) et les matières plastiques (CED 170203) qui constituent l'emballage des carreaux, doivent être recyclés selon les règles du tri sélectif. Pour toute information supplémentaire sur la pose des carreaux, vous pouvez contacter l'assistance commerciale Ragno. Pour plus de renseignements, veuillez visiter le site Ecolabel : <http://www.ecolabel.eu>

Serie con certificazione Ecolabel / Series with Ecolabel certification / Serien mit Ecolabel-Zertifikat / Séries certifiées Ecolabel / Series con certificación Ecolabel / Серии с сертификатом Ecolabel

Ragno has obtained the EU Ecolabel, a European Union ecological quality mark that guarantees lower energy consumption in production processes, lower atmospheric and wastewater emissions, use of substances that are not dangerous for humans and the environment, use of quarries with correct environmental management, more effective consumer information and improved waste management. Thanks to this label of excellence, Ragno meets the Minimum Environmental Criteria (CAM) required for public procurement. At the EMAS - Ecolabel conference in Rome on 1 March 2006, the Italian Ministry of the Environment presented Marazzi Group with a special award for its commitment and focus on the environment. Protecting the environment is a commitment of fundamental importance for everyone, because the environment is "home to us all". The tiles or their cuts that remain after installation are waste that is non-hazardous for the environment and is designed to be recycled. They must be assigned the European waste code EWC 170103 (tiles only) or EWC 170107 (aggregated with other demolition building material) and can be recycled as a road surface material, reclaimed filling material or for brick production. The cardboard (EWC 150101), wood (EWC 170201) and plastic materials (EWC 170203) that make up the tiles' packaging must be appropriately recycled. For more information regarding installation of the tiles, contact the Ragno sales assistance service. More information is available on the Ecolabel website: <http://www.ecolabel.eu>

Ragno también ha obtenido la etiqueta EU Ecolabel, marca de calidad ecológica de la Unión Europea que certifica un menor consumo energético en los procesos de fabricación, menos emisiones al aire, menos vertidos al agua, la utilización de substancias no peligrosas para el ser humano ni para el medio ambiente, la utilización de canteras con una correcta gestión medioambiental, así como una mejor información al consumidor y una mejor gestión de los residuos. Gracias a esta etiqueta de excelencia, Ragno responde a los criterios medioambientales mínimos (CAM) previstos en las adjudicaciones de obras públicas. Con ocasión del congreso EMAS - Ecolabel de Roma del 1 de marzo de 2006, el Ministerio italiano de Medio Ambiente y Salvaguardia del Territorio le concedió a Marazzi Group un galardón especial por su compromiso y su desvelo en pro del medio ambiente. El respeto medioambiental constituye un compromiso de fundamental importancia para todos, porque el medio ambiente es la "casa de todos". Los azulejos y los fragmentos sobrantes después de las operaciones de colocación constituyen residuos no peligrosos para el medio ambiente, y son destinados al reciclaje. Tienen que eliminarse de conformidad con los códigos del catálogo europeo de residuos CER 170103 (solo azulejos) o CER 170107 (unidos a otros materiales de la construcción de demolición) y se pueden reciclar como material para la pavimentación vial, material de relleno en obras de saneamiento y para la fabricación de ladrillos. El cartón (CER 150101), la madera (CER 170201) y los materiales plásticos (CER 170203) que conforman el embalaje de los azulejos deben entregarse para su reciclaje ateniéndose a los criterios de la recogida selectiva. Para más información acerca de la colocación de los azulejos pueden ponerse en contacto con el servicio de asistencia a la venta de Ragno. Se halla a disposición información más detallada en el sitio del certificado Ecolabel: <http://www.ecolabel.eu>

Concept Jazz

Ragno wurde mit dem EU-Ecolabel, dem Europäischen Umweltzeichen, ausgezeichnet. Es bürgt für sparsamen Energieverbrauch der Herstellungsprozesse, geringere Schadstoffemissionen in Wasser und Luft, Verwendung von ungefährlichen Stoffen für Mensch und Umwelt, nachhaltige Nutzung der Abbaustätten, bessere Verbraucherinformation und optimiertes Abfallmanagement. Dank diesem Gütesiegel entspricht die Ragno den Mindestumweltkriterien (MUK) für die Vergabe öffentlicher Aufträge. Im Rahmen der EMAS - Ecolabel Tagung in Rom am 1. März 2006 wurde Marazzi Group vom italienischen Ministerium für Umwelt und Landschafts- und Meeresschutz mit einem Sonderpreis für das Engagement für Umwelt und Nachhaltigkeit ausgezeichnet. Umweltschutz ist für alle von grundlegender Bedeutung, denn die Umwelt ist das „Zuhause von allen“. Auf der Baustelle anfallende Fliesen- und Fliesenschnittreste stellen keine Belastung für die Umwelt da und sind für die Wiederverwertung bestimmt. Sie sind gemäß dem Europäischen Abfallkatalog mit dem EAV-Code 170103 (nur Fliesen) oder EAV-Code 170107 (Gemische mit anderen Baustoffen) zu entsorgen und können als Füll- oder Schüttmaterial im Wege- und Tiefbau und in der Ziegelproduktion wiederverwertet werden. Pappe (EAV-Code 150101), Holz (EAV-Code 170201) und Kunststoffe (EAV-Code 170203) der Fliesenverpackungen sind durch Getrennsammlung der Wiederverwertung zuzuführen. Für ausführliche Informationen zur Verlegung von Fliesen wenden Sie sich bitte an den Vertriebservice von Ragno. Weiterführende Informationen zum Ecolabel finden Sie im Internet auf <http://www.ecolabel.eu>

Ragno получила маркировку ЕС Ecolabel - маркировку экологического качества Евросоюза, гарантирующую наименьшее потребление энергии в производственных процессах, наименьшие выбросы в атмосферу и в воду, использование не вредных веществ для человека и окружающей среды, более полное информирование потребителя и наилучший менеджмент отходов. Благодаря этой маркировке, подтверждающей совершенство, Ragno отвечает минимальным критериям по окружающей среде (CAM), предусмотренным для государственных подрядов. На конгрессе Emas - Ecolabel, проходившем в Риме 1 марта 2006 года, Министерством природы и охраны территории Италии группе Marazzi Group была присуждена специальная награда за внимание и вклад в дело защиты окружающей среды. Уважительное отношение к природе играет первостепенную роль для всех, так как окружающая среда является "нашим общим домом". Плитка и ее обрезки, оставшиеся после установки, являются неопасными для окружающей среды отходами, подлежащими повторному использованию. Они должны утилизироваться с европейским кодом отходов EWC 170103 (только плитка) или EWC 170107 (смесь с другим строительным мусором) и могут повторно использоваться для изготовления подушек в дорожном строительстве, в качестве материала для отсыпки при мелiorации, в производстве кирпича. Картон (EWC 150101), дерево (EWC 170201) и пластмасса (EWC 170203), из которых изготавливается упаковка плитки, должны сдаваться в утиль отдельно. Для получения более подробной информации по установке плитки можно обращаться в отдел реализации компании Ragno. Более подробная информация доступна на сайте, посвященном маркировке Ecolabel: <http://www.ecolabel.eu>

La certificazione CCC, introdotta nel 2002 interessa sia i prodotti di importazione che quelli di produzione cinese destinati a quel mercato. Le informazioni sulla certificazione CCC riguardano in generale la sicurezza e la salute, con particolare riferimento, nel caso delle piastrelle di ceramica, alle sole piastrelle in gres porcellanato, con un assorbimento minore o uguale allo 0,5%. La certificazione si ottiene attraverso l'intervento di istituti appositamente accreditati dalle autorità cinesi, tutti con sede in Cina.

La certification CCC, introduite en 2002, intéresse aussi bien les produits d'importation que ceux de production chinoise destinés à ce marché. Les informations sur la certification CCC concernent en général la sécurité et la santé, avec une référence toute particulière, dans le cas des carreaux en céramique, uniquement aux carreaux en grès cérame, à absorption inférieure ou égale à 0,5%. On l'obtient par l'intermédiaire d'organismes de certification et d'accréditation chinois, tous avec siège en Chine.



Il programma di certificazione NSF Food Equipment ha 22 diversi standard che stabiliscono i requisiti minimi di protezione e igiene alimentare riguardo ai materiali, la progettazione, la fabbricazione, la costruzione e le prestazioni delle attrezzature per la manipolazione e il trattamento degli alimenti. I materiali per superfici solide vengono esaminati in base alla "NSF / ANSI 51: Materiali per attrezzature alimentari", che specifica i requisiti relativi alla salute pubblica per i materiali utilizzati nella costruzione di attrezzature alimentari commerciali. Maggiori informazioni sono disponibili sul sito: <http://info.nsf.org/Certified/Food/>

The NSF Food Equipment certification programme has 22 different standards that set minimum food hygiene and protection requirements for the materials, design, manufacturing, construction and performance of equipment for handling and processing food. The materials for solid surfaces are examined based on the "NSF/ANSI 51: Food Equipment Materials" standard, which specifies the public health requirements for materials used in the construction of commercial food equipment. More information is available on the website: <http://info.nsf.org/Certified/Food/>

Le programme de certification et d'enregistrement d'équipement alimentaire NSF Food Equipment comporte 22 normes définissant les exigences minimales de protection et d'hygiène alimentaire



CCC certification, introduced in 2002, applies to products both imported to China and produced in the country for the Chinese market. Information concerning CCC certification generally relates to health and safety. In the case of ceramic tiles, reference is made specifically only to porcelain tiles having water absorption of 0.5% or less. Certification is obtained through institutions specifically accredited by the Chinese authorities, all based in China.

La certificación CCC, introducida en el 2002, concierne tanto a los productos de importación como a los de producción china destinados a ese mismo mercado. La información acerca de la certificación CCC atañe en general a la seguridad y la salud, con especial referencia, en el caso de las baldosas de cerámica, solamente a las baldosas de gres porcelánico, con una absorción inferior o igual al 0,5%. Se consigue a través de la intervención de instituciones específicamente acreditadas por las autoridades chinas, todas ellas sitas en China.

concernant les matériaux, la conception, la fabrication, la construction et la performance de l'équipement pour la manipulation et pour le traitement des aliments. Les matériaux pour surfaces solides sont examinés selon la norme « NSF / ANSI 51 : Matériaux pour équipement alimentaire », qui précise les exigences relatives à la santé publique pour les matériaux utilisés dans la construction d'équipements alimentaires commerciaux. Pour plus d'informations, veuillez visiter le site : <http://info.nsf.org/Certified/Food/>

Das NSF Commercial Food Equipment Zertifizierungsprogramm hat 22 verschiedene Standards vorgesehen, die die Mindestanforderungen an Lebensmittelsicherheit und -hygiene in Bezug auf die Werkstoffe, Planung, Fertigung, Konstruktion und die Leistungen von Anlagen für die Lebensmittelhandhabung und -verarbeitung festlegen. Die Werkstoffe für feste Oberflächen werden auf Basis des Standards "NSF / ANSI 51: Werkstoffe für Anlagen der Lebensmittelindustrie" geprüft, der die Anforderungen an die öffentliche Gesundheit für die zur Konstruktion von Anlagen der Lebensmittelindustrie verwendeten Werkstoffe spezifiziert. Weiterführende Informationen auf der Website: <http://info.nsf.org/Certified/Food/>

El programa de certificación NSF Food Equipment tiene veintidós estándares que establecen los requisitos mínimos de protección e higiene alimentaria con



Die im Jahr 2002 eingeführte CCC-Zertifizierung betrifft sowohl in China importierte als auch in China produzierte Erzeugnisse, die für den chinesischen Markt bestimmt sind. Die Informationen über die CCC-Zertifizierung betreffen im Allgemeinen die Sicherheit und Gesundheit und im Bereich von Keramikfliesen insbesondere die Feinsteinzeugfliesen mit einer Wasseraufnahme kleiner oder gleich 0,5 %. Die Zertifizierungsverfahren erfolgt durch die von den chinesischen Behörden akkreditierten Stellen, die sämtlich ihren Geschäftssitz in China haben.

Система сертификации CCC, вступившая в действие в 2002 году, применяется как на импортную, так и на китайскую отечественную продукцию, предназначенную для китайского рынка. Вообще, сведения о сертификации CCC касаются безопасности и здоровья; в частности, в случае керамической плитки, они относятся только к плитке из гres порцеланита, с водопоглощением менее или равным 0,5%. Сертификацию осуществляют специально аккредитованные у китайских властей институты, все они располагаются в Китае.

respecto a los materiales, el diseño, la fabricación, la construcción y las prestaciones de los equipos para la manipulación y el tratamiento de los alimentos. Los materiales para superficies sólidas se examinan con arreglo a la "NSF / ANSI 51: Materiales de equipos alimentarios", que especifica los requisitos relativos a la salud pública en referencia a los materiales utilizados en la construcción de equipos alimentarios comerciales. Se halla a disposición información más detallada en el sitio web: <http://info.nsf.org/Certified/Food/>

Программа сертификации NSF Food Equipment включает в себя 22 стандарта, которые устанавливают минимальные требования к пищевой безопасности и гигиене в том, что касается материалов, проектирования, производства, изготовления и характеристик оборудования, предназначенного для обращения и обработки продуктов питания. Материалы твердых поверхностей исследуются в соответствии со стандартом "NSF / ANSI 51: Материалы оборудования для пищевой промышленности", который устанавливает требования, касающиеся обеспечения безопасности для здоровья людей материалов, используемых в изготовлении коммерческого оборудования для пищевой промышленности. Более подробная информация доступна на сайте: <http://info.nsf.org/Certified/Food/>



La filosofia di Marazzi Group è da sempre improntata al conseguimento di un prodotto tecnicamente all'avanguardia e dagli elevati standard qualitativi ed estetici. Marazzi Group è stata una delle prime aziende operanti nel settore ad aver ottenuto nel 1994 la certificazione ISO 9001 del proprio sistema di gestione della Qualità aziendale, dalla progettazione e sviluppo del prodotto, ai processi produttivi e alle attività di servizio. Marazzi Group dedica una grandissima attenzione all'ambiente, con la consapevolezza di dover gestire, con un approccio attivo, le problematiche derivanti dalla presenza produttiva sul territorio. Nel 2003 ha certificato il proprio sistema di gestione Ambientale secondo la norma ISO 14001. La sicurezza del personale è di fondamentale importanza per l'azienda, che cerca il miglioramento continuo attraverso costanti verifiche e controlli, investimenti e formazione, con il coinvolgimento diretto dei lavoratori. L'impegno di Marazzi Group è dimostrato dalla certificazione OH SAS 18001 del sistema di gestione della Salute e Sicurezza sul Lavoro.

The philosophy of Marazzi Group has always been geared towards achieving a technically advanced product with high quality and aesthetic standards. Marazzi Group was one of the first firms in the industry to obtain ISO 9001 certification, in 1994, for its quality management system, from product design and development to production processes and service activities. Marazzi Group pays considerable attention to the environment, conscious of its duty to take an active approach to managing the problems that derive from manufacturing in the area. In 2003, its environmental management system was certified according to the ISO 14001 standard. Employee safety is of fundamental importance for the company, which strives towards continuous improvement through constant tests and checks, investments and training, directly involving workers. The commitment of Marazzi Group is demonstrated by the OHSAS 18001 certification for the occupational health and safety management system.

Im Vordergrund der Philosophie von Marazzi Group steht von jeher das Streben nach einem technisch wegweisen den Produkt und hohen qualitativen wie ästhetischen Standards. Marazzi Group ist als eines der ersten Unternehmen der Branche bereits seit 1994 nach ISO 9001 zertifiziert. Die Zertifizierung umfasst die Produktplanung und -entwicklung, die Fertigungsprozesse und die technologieintensiven Produkte und Services. Umweltschutz wird bei Marazzi Group groß geschrieben. Deshalb geht das Unternehmen proaktiv mit den Problemen um, die sich aus der Produktionstätigkeit für den Standort und seine Einwohnergemeinschaft ergeben. Im Jahr 2003 erlangte es die Zertifizierung für das Umweltmanagementsystem nach der Norm ISO 14001. Die Mitarbeitersicherheit ist von grundlegender Bedeutung für Marazzi Group. Das belegt ein kontinuierlicher Verbesserungsprozess mit konstanten Prüfungen und Kontrollen, Investitionen und Schulungsmaßnahmen unter direkter Einbeziehung der Mitarbeiter. Marazzi erlangte in Anerkennung dieser Anstrengungen die Zertifizierung des Arbeits- und Gesundheitsschutzmanagements nach OHSAS 18001.

Fidèle à sa philosophie, Marazzi Group a pour objectif de fabriquer un produit technique d'avant-garde et d'atteindre une qualité et une esthétique maximales. Marazzi Group a été l'une des premières entreprises du secteur à obtenir en 1994 la certification ISO 9001 pour son système de management de la qualité : des activités de conception et développement du produit aux processus de production, en passant par les services. Marazzi Group fait preuve d'un vif intérêt pour l'environnement, consciente qu'une démarche active est nécessaire pour gérer les problèmes occasionnés par sa présence sur le territoire. En 2003, l'entreprise a certifié son système de management environnemental selon la norme ISO 14001. Elle accorde une importance fondamentale à la sécurité du personnel et, pour cette raison, vise à une optimisation continue en mettant en œuvre des contrôles et audits fréquents, des investissements et des initiatives de formation avec la participation directe des travailleurs. Marazzi Group prouve son engagement par la certification OHSAS 18001 de son système de management de la santé et de la sécurité au travail.

La filosofia di Marazzi Group siempre se ha orientado hacia la consecución de un producto de vanguardia en lo técnico y de elevados estándares en lo cualitativo y lo estético. Marazzi Group fue una de las primeras empresas del sector en obtener, en 1994, la certificación ISO 9001 de su sistema de gestión de la calidad empresarial, desde el diseño y el desarrollo de los productos hasta los procesos de producción y las actividades de prestación de servicios. Marazzi Group dedica una extraordinaria atención al medio ambiente, consciente de que ha de gestionar con una actitud proactiva los problemas derivados de la presencia productiva en el territorio. En 2003 certificó su sistema de gestión medioambiental con arreglo a la norma ISO 14001. La seguridad del personal es de fundamental importancia para la empresa, que trata de mejorar continuamente por medio de controles y comprobaciones constantes, inversiones y formación, e involucrando de manera directa a los trabajadores. El compromiso de Marazzi Group en este sentido queda demostrado con la obtención de la certificación OHSAS 18001 de su sistema de gestión de la salud y la seguridad en el trabajo.

Принципы работы компании Marazzi Group всегда нацелены на производство технически передовой продукции, с высокими стандартами качества и эстетики. Marazzi Group была одной из первых компаний в этой отрасли, получившей в 1994 году сертификат соответствия стандарту ISO 9001 своей Системы менеджмента качества, охватывающей весь процесс: от проектирования и развития продукции до производственных процессов и деятельности по обслуживанию. Marazzi Group уделяет огромное внимание окружающей среде, осознавая, что она должна иметь активный подход к решению проблем, связанных с наличием производства на территории. В 2003 году она сертифицировала свою Систему экологического менеджмента на соответствие стандарту ISO 14001. Безопасность персонала имеет фундаментальную важность для компании, которая непрерывно работает над улучшениями, постоянно осуществляя проверки и контроль, инвестиции и подготовку при непосредственном участии сотрудников. Предпринимаемые Marazzi Group усилия подтверждаются сертификатом OHSAS 18001 Системы охраны здоровья и обеспечения безопасности труда.



## UNI EN REGULATIONS **LE NORME UNI EN**

die UNI EN-normen - les normes UNI EN - las normas UNI EN - нормы UNI EN

Le norme **UNI EN**, recepite dal CEN, (Commissiòn Euro-peenne de Normalisation), hanno valore in tutta Europa e interessano tutti i tipi di piastrelle, pressate e trafilate, smaltate e non smaltate, di qualunque formato, di sola 1° scelta. Le norme **UNI EN** trovano corrispondenza con alcune modifiche delle nuove norme internazionali **ISO** e si compongono di:

### **NORME GENERALI**

La nuova norma armonizzata **EN 14411** fornisce definizioni, classificazione, caratteristiche e marcatura per le piastrelle di ceramica ed annulla e sostituisce la norma **EN 87**.

La nuova normativa **UNI EN ISO 105454\_1** stabilisce le regole per la composizione del lotto di campionamento e sostituisce la precedente norma **EN 163**.

### **NORME DI PRODOTTO**

Le piastrelle di ceramica sono suddivise in gruppi secondo il metodo di formatura ed il grado di assorbimento d'acqua. Sono contraddistinti due gruppi **A** e **B**, in funzione del metodo di formatura:

**A** Piastrelle estruse (ovvero formate tramite il passaggio della materia allo stato plastico, attraverso un "trafilatore" che costituisce un nastro in seguito tagliato alla misura voluta).

**B** Piastrelle pressate (ovvero ottenute tramite la pressione della materia prima allo stato di polvere secca, in appositi stampi). Tali piastrelle possono essere smaltate successivamente, o non smaltate.

I gruppi sono a loro volta suddivisi in sottogruppi, secondo il grado di assorbimento d'acqua (porosità) presentato:

- Gruppo <b>B Ia</b> = E ≤ 0,5%	<b>UNI EN 14411_G</b>
- Gruppo <b>B Ib</b> = 0,5% < E ≤ 3%	<b>UNI EN 14411_H</b>
- Gruppo <b>B IIa</b> = 3% < E ≤ 6%	<b>UNI EN 14411_J</b>
- Gruppo <b>B IIb</b> = 6% < E ≤ 10%	<b>UNI EN 14411_K</b>
- Gruppo <b>B III</b> = E > 10%	<b>UNI EN 14411_L</b>

Le norme definiscono per ogni gruppo di prodotti le dimensioni, le tolleranze dimensionali, le caratteristiche meccaniche, fisiche e chimiche, l'aspetto e la designazione delle piastrelle ceramiche. Le piastrelle dell'attuale gamma Ragno sono tutte ottenute per pressatura e appartengono ai gruppi B Ia, B Ib, B IIa, B III.

### **NORME PER I METODI DI PROVA**

Queste norme definiscono i metodi per la determinazione delle caratteristiche dimensionali e di aspetto, delle proprietà fisiche e delle proprietà chimiche.

La norma **14411** fa riferimento ai metodi di prova delle nuove norme **UNI EN ISO 10545**.

The **UNI EN** standards, adopted by the CEN (European Committee for Standardization) are valid throughout Europe and apply to all types of first choice tiles, pressed and extruded, glazed and unglazed, of any size. The **UNI EN** standards are compatible with the latest amendments of the new **ISO** international standards, and include:

### **GENERAL REGULATIONS**

The new harmonised standard **EN 14411** that provides definitions, classifications, features and designation requirements for ceramic tiles and annuls and replaces standard **EN 87**.

The new standard **UNI EN ISO 105454\_1** that sets forth the rules for the composition of sample lots, and replaces the previous standard **EN 163**.

### **PRODUCT REGULATIONS**

Ceramic tiles are divided into groups according to how they are formed and their water absorption characteristics. In terms of forming methods, there are two groups: **A** and **B**:

**A** Extruded tiles (formed by means of passing a malleable paste through an extrusion machine; the resulting band is cut into the desired dimensions).

**B** Pressed tiles (obtained by pressing powdered raw materials in special molds). Afterwards, these tiles may be glazed or not.

The groups are broken down further according to their water absorption characteristics (porosity):

- Group <b>B Ia</b> = E ≤ 0,5%	<b>UNI EN 14411_G</b>
- Group <b>B Ib</b> = 0,5% < E ≤ 3%	<b>UNI EN 14411_H</b>
- Group <b>B IIa</b> = 3% < E ≤ 6%	<b>UNI EN 14411_J</b>
- Group <b>B IIb</b> = 6% < E ≤ 10%	<b>UNI EN 14411_K</b>
- Group <b>B III</b> = E > 10%	<b>UNI EN 14411_L</b>

The regulations define the sizes, the size tolerances, the mechanical, physical and chemical properties, the appearance and designation of the ceramic tiles in each group. The present range of Ragno tiles is entirely composed of pressed tiles and belongs to groups B Ia, B Ib, B IIa, and B III.

### **REGULATIONS FOR TESTING METHODS**

These regulations define the methods to be used for determining size and appearance characteristics, as well as physical and chemical properties.

Standard **14411** refers to the testing methods of the new **UNI EN ISO 10545** standard.

Die vom CEN (Europäisches Komitee für Normung) aufgenommenen **UNI EN**-Normen sind in ganz Europa gültig und betreffen alle Typen von gepressten, gezogenen, glasierten und unglasierten Fliesen jeglichen Formats ausschließlich erster Wahl. Die **UNI EN** Normen finden mit einigen Änderungen der neuen internationalen **ISO**-Normen Entsprechung und setzen sich wie folgt zusammen:

### **ALLGEMEINE NORMEN**

Die neue harmonisierte Norm **EN 14411** gibt Begriffe, Klassifizierung, Gütemerkmale und Kennzeichnung für keramische Fliesen an und annulliert und ersetzt die Norm **EN 87**.

Die neue Norm **UNI EN ISO 105454\_1** legt die Regeln für die Zusammensetzung des Musterungsloses fest und ersetzt die vorherige Norm **EN 163**.

### **PRODUKTNORMEN**

Keramikfliesen werden nach ihrer Formungsweise und ihres Wasseraufnahmevermögens in Gruppen eingeteilt. Je nach der Formungsmethode werden die Gruppen **A** und **B** unterschieden:

**A** Gezogene Fliesen (das heißt Fliesen, die durch den Durchgang des Materials im plastischen Zustand durch eine Strangpresse zu einem Streifen geformt werden, der anschließend in einzelne Fliesen mit dem gewünschten Maß zerschnitten wird).

**B** Gepreßte Fliesen (die ausgehend von Rohmaterialien in Pulverform durch Pressung in speziellen Formwerkzeugen erzielt werden). Diese Fliesen können anschließend glasiert werden oder unglasiert bleiben.

Diese Gruppen werden wiederum nach ihrer Wasseraufnahme (Porosität) in Gruppen eingeteilt:

- Gruppe <b>B Ia</b> = E ≤ 0,5%	<b>UNI EN 14411_G</b>
- Gruppe <b>B Ib</b> = 0,5% < E ≤ 3%	<b>UNI EN 14411_H</b>
- Gruppe <b>B IIa</b> = 3% < E ≤ 6%	<b>UNI EN 14411_J</b>
- Gruppe <b>B IIb</b> = 6% < E ≤ 10%	<b>UNI EN 14411_K</b>
- Gruppe <b>B III</b> = E > 10%	<b>UNI EN 14411_L</b>

Die Normen bestimmen für jede Produktgruppe Abmessungen, Maßtoleranzen, mechanische, physikalische und chemische Eigenschaften, Aussehen und die Bezeichnung der Keramikfliesen. Alle Fliesen der derzeitigen Ragno-Produktpalette werden durch Pressung erzielt und gehören den Gruppen B Ia, B Ib, B IIa, B III an.

### **NORMEN FÜR DIE PRÜFMETHODEN**

Diese Normen bestimmen die Methoden zur Feststellung der Eigenschaften hinsichtlich der Abmessungen und des Aussehens, der physikalischen und der chemischen Merkmale. Die Norm **14411** bezieht sich auf die Prüfmethode nach den neuen Normen **UNI EN ISO 10545**.

Les normes **UNI EN**, reconnues par le CEN (Comité Européen de Normalisation), sont valables dans toute l'Europe et concernent tous les types de carreaux, pressés et étreés, émaillés et non émaillés, de n'importe quel format, exclusivement de premier choix. Les normes **UNI EN** se sont adaptées aux dernières dispositions des nouvelles normes internationales **ISO** et se composent de:

### **NORMES GÉNÉRALES**

La nouvelle norme harmonisée **EN 14411** qui fixe les définitions, la classification, les caractéristiques et le marquage des carreaux céramiques, annule et remplace la norme **EN 87**.

La nouvelle norme **UNI EN ISO 105454\_1** établit les règles pour la composition du lot d'échantillonnage et remplace la norme **EN 163**.

### **NORMES DE PRODUIT**

Les carreaux en céramique sont divisés en groupes selon le type de façonnage et leur porosité. Ils font partie de la classe **A** ou **B** suivant le type de façonnage:

**A** Carreaux extrudés (c'est-à-dire façonnés par le passage de la matière à l'état plastique dans une extrudeuse; la bande formée est ensuite coupée à la mesure désirée).

**B** Carreaux pressés (c'est-à-dire obtenus par pression de la matière première à l'état de poudre sèche, dans des moules spéciaux). Ces carreaux peuvent ensuite être émaillés ou non.

Les groupes sont divisés en sous-groupes suivant le degré d'absorption d'eau (porosité):

- Groupe <b>B Ia</b> = E ≤ 0,5%	<b>UNI EN 14411_G</b>
- Groupe <b>B Ib</b> = 0,5% < E ≤ 3%	<b>UNI EN 14411_H</b>
- Groupe <b>B IIa</b> = 3% < E ≤ 6%	<b>UNI EN 14411_J</b>
- Groupe <b>B IIb</b> = 6% < E ≤ 10%	<b>UNI EN 14411_K</b>
- Groupe <b>B III</b> = E > 10%	<b>UNI EN 14411_L</b>

Les normes définissent, pour chaque groupe de produits, les dimensions, les tolérances dimensionnelles, les caractéristiques mécaniques, physiques et chimiques, l'aspect et la désignation des carreaux céramiques. Les carreaux de la gamme Ragno sont tous obtenus par pressage et appartiennent aux groupes B Ia, B Ib, B IIa, B III.

### **NORMES POUR LES METHODES D'ESSAI**

Ces normes définissent les méthodes pour la détermination des caractéristiques dimensionnelles et d'aspect, des propriétés physiques et des propriétés chimiques.

La norme **14411** se réfère aux méthodes d'essai des nouvelles normes **UNI EN ISO 10545**.

Las normas **UNI EN**, acogidas por el CEN (Comisión Europea para la Normalización), se consideran válidas en toda Europa y comprenden todas las categorías de azulejos, prensados o extruidos, esmaltados y no esmaltados, de cualquier formato, únicamente de 1ª calidad. Las normas **UNI EN** están en sintonía con algunas modificaciones de las nuevas normas internacionales **ISO** y están formadas por:

### **NORMAS GENERALES**

La nueva norma armonizada **EN 14411**, que facilita las reglas para la composición de la partida de muestreo y denominación para los azulejos de cerámica y anula y sustituye a la norma **EN 87**.

La nueva normativa **UNI EN ISO 105454\_1**, que establece las reglas para la composición de la partida de muestreo y sustituye a la norma anterior **EN 163**.

### **NORMAS DE PRODUCTO**

Los azulejos cerámicos se dividen en grupos según el método de moldeo utilizado y el nivel de absorción del agua. Se distinguen 2 grupos **A** y **B** en función del método de moldeo:

**A** Azulejos extruidos (es decir, que se forman pasando la materia al estado plástico por medio de una "extrusora-nadora", que forma por una cinta que luego se corta de acuerdo con la medida deseada).

**B** Azulejos prensados (es decir, que se forman prensando la materia prima en polvo seco dentro de moldes especiales). Se trata de azulejos que se pueden esmaltar sucesivamente o dejar sin esmalte.

Los grupos se dividen a su vez en grupos secundarios de acuerdo con el nivel de absorción del agua (porosidad):

- Grupo <b>B Ia</b> = E ≤ 0,5%	<b>UNI EN 14411_G</b>
- Grupo <b>B Ib</b> = 0,5% < E ≤ 3%	<b>UNI EN 14411_H</b>
- Grupo <b>B IIa</b> = 3% < E ≤ 6%	<b>UNI EN 14411_J</b>
- Grupo <b>B IIb</b> = 6% < E ≤ 10%	<b>UNI EN 14411_K</b>
- Grupo <b>B III</b> = E > 10%	<b>UNI EN 14411_L</b>

Las normas establecen por cada grupo de productos, las dimensiones, las tolerancias dimensionales, las características mecánicas, físicas y químicas, el aspecto y la denominación de azulejos cerámicos.

Los azulejos de la actual gama Ragno se obtienen mediante prensado y pertenecen a los grupos B Ia, B Ib, B IIa, B III.

### **NORMAS PARA LOS MÉTODOS DE PRUEBA**

Dichas normas establecen los métodos para la determinación de las características dimensionales y de aspecto, de las propiedades físicas y de las propiedades químicas. La norma **14411** se refiere a los métodos de prueba de las nuevas normas **UNI EN ISO 10545**.

Normы **UNI EN**, принятые CEN (Comité Européen de Normalisation), имеют силу во всей Европе и распространяются на все типы плитки, прессованные и экструдированные, глазурованные и неглазурованные, любого формата, только 1 сорта. Нормы UNI EN соответствуют некоторым изменениям новых международных норм и включают в себя:

### **ОБЩИЕ НОРМЫ**

Новая согласованная норма **EN 14411** приводит определения, классификацию, характеристики и требования к маркировке керамической плитки, она отменяет и заменяет норму **EN 87**.

Новая норма **UNI EN ISO 105454\_1** определяет правила составления опытной партии и заменяет предыдущую норму **EN 163**.

### **НОРМЫ НА ПРОДУКЦИЮ**

Керамическая плитка подразделяется на группы по методам формовки и степени водопоглощения.

В зависимости от метода формовки выделяются две группы - **A** и **B**:

**A** Экструдированная плитка (то есть образованная прохождением пластичного сырья через экструдер и разрезанием иолуенной ленты по необходимому размеру).

**B** Прессованная плитка (то есть полученная прессованием сырья в виде сухого порошка в специальных пресс-формах). Далее эта плитка может глазуроваться или нет.

В свою очередь, группы подразделяются на подгруппы по степени имеющегося водопоглощения (пористости):

- Группа <b>B Ia</b> = E ≤ 0,5%	<b>UNI EN 14411_G</b>
- Группа <b>B Ib</b> = 0,5% < E ≤ 3%	<b>UNI EN 14411_H</b>
- Группа <b>B IIa</b> = 3% < E ≤ 6%	<b>UNI EN 14411_J</b>
- Группа <b>B IIb</b> = 6% < E ≤ 10%	<b>UNI EN 14411_K</b>
- Группа <b>B III</b> = E > 10%	<b>UNI EN 14411_L</b>

Для каждой группы продукции нормы определяют размеры, размерные допуски, механические, физические и химические характеристики, внешний вид, назначение керамической плитки. Плитка данной гаммы Ragno полностью получена прессованием и принадлежит к группам B Ia, B Ib, B IIa, B III.

### **НОРМЫ ДЛЯ МЕТОДОВ ИСПЫТАНИЯ**

Эти нормы устанавливают методы определения размерных характеристики и внешнего вида, физических и химических свойств.

Норма **14411** ссылается на методы испытания новых норм **UNI EN ISO 10545**.

CARATTERISTICA CHARACTERISTIC EIGENSCHAFTEN CARACTERISTIQUE CARACTERÍSTICA ХАРАКТЕРИСТИКА	METODO DI PROVA TESTING METHOD PRÜFMETHODE MÉTHODE D'ESSAI MÉTODO DE PRUEBA МЕТОД ИСПЫТАНИЯ	UNITA DI MISURA MEASUREMENT UNIT MABEINHEIT UNITE DE MESURE UNIDAD DE MEDIDA ЕДИНИЦА ИЗМЕРЕНИЯ	VALORI TIPICI MEDI AVERAGE TYPICAL VALUES TYPISCHE DURCHSCHNITTSWERTE VALEURS MOYENNES TYPIQUES VALORES TÍPICOS MEDIOS ТИПОВЫЕ ЗНАЧЕНИЯ	VALORI LIMITE PREVISTI ESTABLISHED LIMITS VORGEGEHENE GRENZWERTE VALEURS LIMITES PREVUES VALORES LIMITE PREVISTOS ПРЕДУСМОТРЕННЫЕ ПРЕДЕЛЬНЫЕ ЗНАЧЕНИЯ	NORMA DI RIFERIMENTO REFERENCE STANDARD BEZUGSNORM NORME DE REFERENCES NORMA DE REFERENCIA СТАНДАРТ ДЛЯ СРАВКИ	
Tolleranze dimensionali Dimensions - Abmessungen Dimensions - Dimensiones Размерные допуски	ISO 10545_2	mm %	Conforme Compliant Konform Conforme Conforme Соответствует	7 ≤ N < 15	N ≥ 15	UNI EN 14411-G
Lunghezza e larghezza Length and width Länge und Breite Longueur et largeur Longitud y anchura Длина и ширина				(a) ± 2% (max 5 mm)	(a) ± 2% (max 5 mm) ± 2% (max 5 mm)	
Ortogonalità - Rectangularity Rechtwinkigkeit - Orthogonalité Ortogonalidad - Ortogonalność				± 0,75 mm	± 0,5% ± 2,0 mm	
Spessore - Thickness Stärke - Epaisseur Espesor - Толщина				± 0,5 mm	± 5% ± 0,5 mm	
Rettilinearità degli spigoli Edge straightness Rechtlinigkeit der Kanten Rectitude des arêtes Rectitud de las esquinas Прямолинейность кромки				± 0,75 mm	± 0,5% ± 1,5 mm	
Planarità - Flatness Ebenflächigkeit - Planéité Planeidad - Плоскостность			(c) ± 0,75 mm	(c) ± 0,5% ± 2,0 mm		
Aspetto - Appearance Aspekt - Aspect Aspecto - Внешний вид				≥ 95%		
Assorbimento d'acqua Water absorption Wasseraufnahme Absorption d'eau Absorción de agua Водопоглощение	ISO 10545_3	%		≤ 0,5 Valore singolo massimo 0,6% Maximum single value 0,6% Maximaler Einzelwert 0,6 Valeur unitaire maximale 0,6 Valor máximo individual 0,6 Максимальное отдельное значение 0,6		
Resistenza alla flessione Resistance to bending Biegefestigkeit Résistance à la flexion Resistencia a la flexión Сопротивление изгибу	ISO 10545_4	N/mm <sup>2</sup>		R ≥ 35 Valore singolo minimo 32 Minimum single value 32 Geringer Einzelwert 32 Valeur unique minimale 32 Valor unico minimo 32 Минимальное отдельное значение 32	UNI EN 14411-G	
Sforzo di rottura Breaking strength Bruchkraft Force de Rupture Esfuerzo de rotura Разрывное усилие	ISO 10545_4	N	Conforme Compliant Konform Conforme Conforme Соответствует	Spessore Thickness Stärke < 7,5 mm Epaisseur Espesor Толщина ≥ 700 N	Spessore Thickness Stärke ≥ 7,5 mm Epaisseur Espesor Толщина ≥ 1300 N	UNI EN 14411-G
Resistenza all'abrasione profonda Resistance to deep abrasion Tiefenabriebfestigkeit Résistance à l'abrasion profonde Resistencia a la abrasión profunda Устойчивость к глубокому истиранию	ISO 10545_6	mm <sup>3</sup>		≤ 175		UNI EN 14411-G
Resistenza al gelo Frost resistance Frostbeständigkeit Résistance au gel Resistencia al helado Морозостойкость	ISO 10545_12		Conforme Compliant Konform Conforme Conforme Соответствует	Prova superata secondo la EN ISO 10545-1 - Test passed in accordance with EN ISO 10545-1 - Prüfung gemäß EN ISO 10545-1 bestanden - Essai réussi conformément à la norme EN ISO 10545-1 - Prueba superada de conformidad con la EN ISO 10545-1 - Испытание пройдено в соответствии со стандартом EN ISO 10545-1		UNI EN 14411-G
Resistenza agli sbalzi termici Thermal shock resistance Widerstandsfähigkeit Temperaturschwankungen Résistance aux chocs thermiques Resistencia al choque térmico Стойкость к тепловым перепадам	ISO 10545_9		Conforme Compliant Konform Conforme Conforme Соответствует	Prova superata secondo la EN ISO 10545-1 - Test passed in accordance with EN ISO 10545-1 - Prüfung gemäß EN ISO 10545-1 bestanden - Essai réussi conformément à la norme EN ISO 10545-1 - Prueba superada de conformidad con la EN ISO 10545-1 - Испытание пройдено в соответствии со стандартом EN ISO 10545-1		UNI EN 14411-G
Coefficiente di dilatazione termica lineare Coefficient of linear thermal expansion Linearer Wärmeausdehnungs-Koeffizient Coefficient lineaire de dilatation thermique Coeficiente de dilatación térmica lineal Коэффициент линейного теплового расширения	ISO 10545_8	X10 <sup>-6</sup> /°C		Valore dichiarato Value declared Erklärter wert Valeur déclarée Valor declarado Заявленное значение		UNI EN 14411-G
Resistenza alle macchie Resistance to staining Beständigkeit gegen Fleckenbildner Résistance aux produits tachants Resistencia a las manchas Стойкость к пятнообразованию	ISO 10545_14		classe 3 minimo class 3 minimum Mind. klasse 3 classe 3 minimum categoria 3 minimo минимум класс 3	Valore dichiarato Value declared Erklärter wert Valeur déclarée Valor declarado Заявленное значение		UNI EN 14411-G

CARATTERISTICA CHARACTERISTIC EIGENSCHAFTEN CARACTERISTIQUE CARACTERÍSTICA ХАРАКТЕРИСТИКА	METODO DI PROVA TESTING METHOD PRÜFMETHODE MÉTHODE D'ESSAI MÉTODO DE PRUEBA МЕТОД ИСПЫТАНИЯ	UNITA DI MISURA MEASUREMENT UNIT MABEINHEIT UNITE DE MESURE UNIDAD DE MEDIDA ЕДИНИЦА ИЗМЕРЕНИЯ	VALORI TIPICI MEDI AVERAGE TYPICAL VALUES TYPISCHE DURCHSCHNITTSWERTE VALEURS MOYENNES TYPIQUES VALORES TÍPICOS MEDIOS ТИПОВЫЕ ЗНАЧЕНИЯ	VALORI LIMITE PREVISTI ESTABLISHED LIMITS VORGEGEHENE GRENZWERTE VALEURS LIMITES PREVUES VALORES LIMITE PREVISTOS ПРЕДУСМОТРЕННЫЕ ПРЕДЕЛЬНЫЕ ЗНАЧЕНИЯ	NORMA DI RIFERIMENTO REFERENCE STANDARD BEZUGSNORM NORME DE REFERENCES NORMA DE REFERENCIA СТАНДАРТ ДЛЯ СРАВКИ
Resistenza ai prodotti chimici di uso domestico e sali per piscina Resistance to chemicals for household use and swimming pool salts Beständigkeit gegen Haushaltschemikalien und Zusätze für Schwimmbäder Résistance aux produits chimiques d'usage domestique et sels pour piscine Resistencia a los productos químicos para uso doméstico y sales para piscina Устойчивость к бытовым химическим соединениям и солям для бассейнов	ISO 10545_13		A	B minimo B minimum Mind. B B minimum B mínimo Минимальный B	UNI EN 14411-G
Resistenza agli acidi e alle basi Resistance to acids and bases Säure- und Laugenfestigkeit Résistance aux acides et aux bases Resistencia a los ácidos y a las bases Стойкость к кислотам и щелочам		LA-LB HA-HB		Valore dichiarato Value declared Erklärter wert Valeur déclarée Valor declarado Заявленное значение	UNI EN 14411-G
Resistenza dei colori alla luce Colour resistance to light exposure Farbtheit unter Lichteinfluss Résistance des couleurs à la lumière Resistencia de los colores a la exposición de la luz Светостойкость цветов	DIN 51094		Conforme Compliant Konform Conforme Conforme Соответствует		Non devono presentare apprezzabili alterazioni di colore / No sample must show noticeable colour modifications / Aucun échantillon ne doit présenter d'altérations appréciables de couleur / Kein Muster darf sichtbare Farbveränderungen aufweisen / Ninguna muestra ha de presentar alteraciones apreciables de color / Ни один из образцов не должен иметь значимых изменений цветов
Resistenza allo scivolamento Skid resistance - Rutschhemmung Résistance au glissement Resistencia al deslizamiento Сопротивление скольжению	RAMP METHOD		GALASSIA R9 Naturale R12 Rock	da R9 a R13 from R9 to R13 von R9 bis R13 de R9 à R13 de R9 a R13 от R9 до R13	DIN 51130 BGR 181*
Resistenza allo scivolamento Skid resistance - Rutschhemmung Résistance au glissement Resistencia al deslizamiento Сопротивление скольжению	RAMP METHOD		GALASSIA B Rock	da A a C from A to C von A bis C de A à C de A a C от A до C	DIN 51097 DGUV information 207-006
Resistenza allo scivolamento Skid resistance - Rutschhemmung Résistance au glissement Resistencia al deslizamiento Сопротивление скольжению	PENDULUM		GALASSIA Rock classe 2 / class 2 / klasse 2 / classe 2 / categoria 2 / класс 2		ENV 12633 BOE N°74 del 2006
Resistenza allo scivolamento Skid resistance - Rutschhemmung Résistance au glissement Resistencia al deslizamiento Сопротивление скольжению	PENDULUM		GALASSIA Rock PTV > 36	0 - 24 Scivoloso - Slippery - Rutschig - Glissant - Resbaladizo - Скользкий 25 - 35 Scivolosità moderata - Moderately slippery - Mäßige Rutschgefahr - Glissance modérée - Deslizamiento moderado - Умеренная скользкость ≥ 36 Basso rischio scivolamento - Low slipping risk - Geringe Rutschgefahr - Risque de glissement faible - Bajo riesgo de deslizamiento - Низкий риск скольжения	BS 7976-2: 2002/ BS EN 13036-4: 2011
Coefficiente di attrito medio Mean coefficient of friction Mittlerer Reibungskoeffizient Coefficient de frottement moyen Coefficient de roce medio Средний коэффициент трения	B.C.R.		GALASSIA Naturale / Rock μ > 0,40		D.M. N°236 14/6/1989

(a) Differenza ammissibile tra dimensione di fabbricazione e dimensione nominale - Permissible difference between work size and nominal size - Zulässige Differenz zwischen Werksmaß und Nennmaß - Différence admissible entre la dimension de fabrication et la dimension nominale - Diferencia admisible entre medida de fabricación y medida nominal - Допустимая разница между фактическим размером изделия и номинальным.

(b) Deviazione ammissibile in % della dimensione media di una singola piastrella (2 o 4 lati) dalla dimensione di fabbricazione - Permissible % variation in the average size of a single tile (2 or 4 sides) from the work size - Zulässige Abweichung, in %, der mittleren Größe einer Einzeile (2 oder 4 Seiten) vom Werksmaß - Déviation admissible en % de la dimension moyenne d'un seul carreau (2 ou 4 côtés) par rapport à la dimension de fabrication - En porcentaje, desviación admisible del tamaño medio de un solo azulejo (2 o 4 lados) con respecto a la medida de fabricación - Допустимое отклонение в % среднего размера каждой плитки (2 или 4 стороны) от фактических размеров.

(c) c.c. Deviazione massima ammissibile della curvatura del centro, in % oppure mm, in rapporto alla diagonale calcolata secondo le dimensioni di fabbricazione | e.c. Deviazione massima ammissibile della curvatura dello spigolo, in % oppure mm, in rapporto alle dimensioni di fabbricazione corrispondenti | w. Deviazione massima ammissibile dello svergolamento, in % oppure mm, in rapporto alla diagonale calcolata secondo le dimensioni di fabbricazione - c.c. Maximum permissible deviation, in % or mm, in the centre curvature from the diagonal calculated on the basis of the work size | e.c. Maximum permissible deviation, in % or mm, from the diagonal curvature from the corresponding work size | w. Maximum permissible deviation in warpage, in % or mm, from the diagonal calculated on the basis of the work size - c.c. Maximal zulässige Abweichung der Mittelpunktwölbung, in % oder mm, bezogen auf die über das Werksmaß berechnete Diagonale | e.c. Maximal zulässige Abweichung der Kantenwölbung, in % oder mm, bezogen auf das zugehörige Werksmaß | w. Maximal zulässige Abweichung der Windschiefte, in % oder mm, bezogen auf die über das Werksmaß berechnete Diagonale - c.c. Déviation maximale admissible de la courbure du centre, en % ou en mm, par rapport à la diagonale calculée selon les dimensions de fabrication | e.c. Déviation maximale admissible de la courbure de l'angle, en % ou en mm, par rapport aux dimensions de fabrication correspondantes | w. Déviation maximale admissible du voile en % ou en mm, par rapport à la diagonale calculée selon les dimensions de fabrication - c.c. En porcentaje o en milímetros, desviación máxima admisible de la curvatura del centro con respecto a la diagonal calculada según las medidas de fabricación | e.c. En porcentaje o en milímetros, desviación máxima admisible del abarquilamiento con respecto a la diagonal calculada según las medidas de fabricación - c.c. Максимальное допустимое отклонение изгиба центра в % или в мм относительно диагонали, рассчитанное по фактическим размерам | e.c. Максимальное допустимое отклонение изгиба кройки в % или в мм по отношению к соответствующим фактическим размерам | w. Максимальное допустимое отклонение перекоса в % или в мм по отношению к диагонали, рассчитанное по фактическим размерам.

N Dimensione nominale (cm) - Nominal dimension (cm) - Dimension nominale (cm) - Nennmaß (cm) - Dimensional nominal (cm) - Номинальный размер (см)

\* Pavimentazioni di ambienti lavorativi e zone operative con superfici sdrucciolevoli. - Flooring of work environments and operating areas with slippery surface. - Bodenbeläge für Arbeitsräume und Arbeitsbereiche mit Rutschgefahr. - Sols de locaux industriels et de zones de travail à surfaces dérapantes. - Pavimentaciones de zonas de trabajo y operativas con superficies resbaladizas. - Полы в рабочих помещениях и рабочих зонах со скользким покрытием.

\*\* Pavimentazioni per zone bagnate con calpestio a piedi scalzi. - Flooring for wet areas to be walked on barefoot. - Bodenbeläge in nassbelasteten Barfußbereichen. - Sols pour zones mouillées avec piétinement pieds nus. - Pavimentaciones para zonas mojadas donde se camina con pies descalzos. - Полы для влажных зон, предназначенные для хождения по ним босиком.

TECHNICAL CHARACTERISTICS **CARATTERISTICHE TECNICHE**

technische eigenschaften - caracteristiques technique - datos tecnicos - технические характеристики

**MAIORA**  
Marble Effect

I dati riportati sulla tabella tecnica si riferiscono solo ai fondi. / Technical chart data refer to plain tiles only. / Die technischen Daten beziehen sich nur auf die Grundfliesen. / Les données figurant dans le tableau technique se rapportent uniquement aux fonds. / Los datos que figuran en la tabla técnica se refieren únicamente a los fondos. / Данные, приведенные в технической таблице, относятся лишь только к фоновой плитке.

CARATTERISTICA CHARACTERISTIC EIGENSCHAFTEN CARACTERISTIQUE CARACTERÍSTICA ХАРАКТЕРИСТИКА	METODO DI PROVA TESTING METHOD PRÜFMETHODE MÉTHODE D'ESSAI MÉTODO DE PRUEBA МЕТОД ИСПЫТАНИЯ	UNITA DI MISURA MEASUREMENT UNIT MABEINHEIT UNITE DE MESURE UNIDAD DE MEDIDA ЕДИНИЦА ИЗМЕРЕНИЯ	VALORI TIPICI MEDI AVERAGE TYPICAL VALUES TYPISCHE DURCHSCHNITTSWERTE VALEURS MOYENNES TYPIQUES VALORES TÍPICOS MEDIOS ТИПОВЫЕ ЗНАЧЕНИЯ	VALORI LIMITE PREVISTI ESTABLISHED LIMITS VORGEGEHENE GRENZWERTE VALEURS LIMITES PREVUES VALORES LIMITE PREVISTOS ПРЕДУСМОТРЕННЫЕ ПРЕДЕЛЬНЫЕ ЗНАЧЕНИЯ	NORMA DI RIFERIMENTO REFERENCE STANDARD BEZUGSNORM NORME DE REFERENCES NORMA DE REFERENCIA СТАНДАРТ ДЛЯ СРАВКИ
Tolleranze dimensionali Dimensions - Abmessungen Dimensions - Dimensiones Размерные допуски	ISO 10545_2	mm %	Conforme Compliant Konform Conforme Conforme Соответствует	N ≥ 15	UNI EN 14411-G
Lunghezza e larghezza Length and width Länge und Breite Longueur et largeur Longitud y anchura Длина и ширина				(a) ± 2% (max 5 mm) ± 2% (max 5 mm)	
Ortogonalità - Rectangularity Rechtwinkligkeit - Orthogonalité Ortogonalidad - Ортогональность				± 0,5% ± 2,0 mm	
Spessore - Thickness Stärke - Epaisseur Espesor - Толщина				± 5% ± 0,5 mm	
Rettilinearità degli spigoli Edge straightness Rechtlinigkeit der Kanten Rectitude des arêtes Rectitud de las esquinas Плосколиннейность кромок				± 0,5% ± 1,5 mm	
Planarità - Flatness Ebenförmigkeit - Planéité Planeidad - Плоскостность				(c) ± 0,5% ± 2,0 mm	
Aspetto - Appearance Aspekt - Aspect Aspecto - Внешний вид				≥ 95%	
Assorbimento d'acqua Water absorption Wasseraufnahme Absorption d'eau Absorción de agua Водопоглощение	ISO 10545_3	%		≤ 0,5 Valore singolo massimo 0,6% Maximum single value 0,6% Maximaler Einzelwert 0,6 Valeur unitaire maximale 0,6 Valor máximo individual 0,6 Максимальное отдельное значение 0,6	
Resistenza alla flessione Resistance to bending Biegefestigkeit Résistance à la flexion Resistencia a la flexión Сопротивление изгибу	ISO 10545_4	N/mm²		R ≥ 35 Valore singolo minimo 32 Minimum single value 32 Geringer Einzelwert 32 Valeur unique minimale 32 Valor unico minimo 32 Минимальное отдельное значение 32	UNI EN 14411-G
Sforzo di rottura Breaking strength Bruchkraft Force de Rupture Esfuerzo de rotura Разрывное усилие	ISO 10545_4	N		≥ 700	UNI EN 14411-G
Resistenza all'abrasione profonda Resistance to deep abrasion Tiefenabriebfestigkeit Résistance à l'abrasion profonde Resistencia a la abrasión profunda Устойчивость к глубокому истиранию	ISO 10545_6	mm³	120-150	≤ 175	UNI EN 14411-G
Resistenza all'abrasione superficiale Resistance to surface abrasion Abriebfestigkeit Résistance à l'abrasion superficielle Resistencia a la abrasión superficial Стойкость к поверхностному истиранию	metodo interno internal method Interne Methode méthode interne método interno внутренний метод	classe interna internal class Interne Klassifizierung classe interne clase interna внутренний класс	G Naturale/Matt F Glossy		UNI EN 14411-G
Resistenza al gelo Frost resistance Frostbeständigkeit Résistance au gel Resistencia al helado Морозостойкость	ISO 10545_12			Conforme Compliant Konform Conforme Conforme Соответствует	UNI EN 14411-G
Resistenza agli sbalzi termici Thermal shock resistance Widerstandsfähigkeit Temperaturschwankungen Résistance aux chocs thermiques Resistencia al choque térmico Стойкость к тепловым колебаниям	ISO 10545_9			Conforme Compliant Konform Conforme Conforme Соответствует	UNI EN 14411-G
Coefficiente di dilatazione termica lineare Coefficient of linear thermal expansion Linearer Wärmeausdehnungs-Koeffizient Coefficient lineaire de dilatation thermique Coeficiente de dilatación térmica lineal Коэффициент линейного теплового расширения	ISO 10545_8	X10 <sup>-6</sup> /°C		≤ 9	UNI EN 14411-G

CARATTERISTICA CHARACTERISTIC EIGENSCHAFTEN CARACTERISTIQUE CARACTERÍSTICA ХАРАКТЕРИСТИКА	METODO DI PROVA TESTING METHOD PRÜFMETHODE MÉTHODE D'ESSAI MÉTODO DE PRUEBA МЕТОД ИСПЫТАНИЯ	UNITA DI MISURA MEASUREMENT UNIT MABEINHEIT UNITE DE MESURE UNIDAD DE MEDIDA ЕДИНИЦА ИЗМЕРЕНИЯ	VALORI TIPICI MEDI AVERAGE TYPICAL VALUES TYPISCHE DURCHSCHNITTSWERTE VALEURS MOYENNES TYPIQUES VALORES TÍPICOS MEDIOS ТИПОВЫЕ ЗНАЧЕНИЯ	VALORI LIMITE PREVISTI ESTABLISHED LIMITS VORGEGEHENE GRENZWERTE VALEURS LIMITES PREVUES VALORES LIMITE PREVISTOS ПРЕДУСМОТРЕННЫЕ ПРЕДЕЛЬНЫЕ ЗНАЧЕНИЯ	NORMA DI RIFERIMENTO REFERENCE STANDARD BEZUGSNORM NORME DE REFERENCES NORMA DE REFERENCIA СТАНДАРТ ДЛЯ СРАВКИ
Resistenza alle macchie Resistance to staining Beständigkeit gegen Fleckenbildner Résistance aux produits tachants Resistencia a las manchas Стойкость к пятнообразованию	ISO 10545_14		Naturale/Matt class 5 - class 5 - klasse 5 - classe 5 - categoria 5 - класс 5  Glossy da classe 5 a classe 3 - class 5 to class 3 - von Klasse 5 bis Klasse 3 - de classe 5 à classe 3 - de categoria 5 a categoria 3 - от класс 5 до класс 3	class 3 minimo class 3 minimum Mind. klasse 3 class 3 minimum categoria 3 mínimo минимум класс 3	UNI EN 14411-G
Resistenza ai prodotti chimici di uso domestico e sali per piscina - Resistance to chemicals for household use and swimming pool salts - Beständigkeit gegen Haushaltschemikalien und Zusätze für Schwimmbäder - Résistance aux produits chimiques d'usage domestique et sels pour piscine - Resistencia a los productos químicos para uso doméstico y sales para piscina - Устойчивость к бытовым химическим средствам и солям для бассейнов	ISO 10545_13		A Naturale/Matt A-B Glossy	B minimo B minimum Mind. B B minimum B mínimo Минимальный UB	UNI EN 14411-G
Resistenza agli acidi e alle basi Resistance to acids and bases Säure- und Laugenfestigkeit Résistance aux acides et aux bases Resistencia a los ácidos y a las bases Стойкость к кислотам и щелочам			LA - LB HA - HB	Valore dichiarato Value declared Erklärter wert Valeur déclarée Valor declarado Заявленное значение	UNI EN 14411-G
Resistenza dei colori alla luce Colour resistance to light exposure Farbchtheit unter Lichteinfluss Résistance des couleurs à la lumière Resistencia de los colores a la exposición de la luz Светостойкость цветов	DIN 51094		Conforme Compliant Konform Conforme Conforme Соответствует	Non devono presentare apprezzabili alterazioni di colore - No sample must show noticeable colour modifications - Aucun échantillon ne doit présenter d'altérations appréciables de couleur - Kein Muster darf sichtbare Farbveränderungen aufweisen - Ninguna muestra ha de presentar alteraciones apreciables de color - Ни один из образцов не должен иметь значимых изменений цветов	
Resistenza allo scivolamento - Skid resistance - Rutschhemmung - Résistance au glissement Resistencia al deslizamiento - Сопротивление скольжению	RAMP METHOD		R9 Naturale/Matt	da R9 a R13 - from R9 to R13 - von R9 bis R13 - de R9 à R13 - de R9 a R13 - от R9 до R13	DIN 51130 BGR 181*
Coefficiente di attrito medio Mean coefficient of friction Mittlerer Reibungskoeffizient Coefficient de frottement moyen Coefficient de roce medio Средний коэффициент трения	B.C.R.		μ > 0,40 Naturale/Matt	μ > 0,40	D.M. N°236 14/6/1989
Resistenza allo scivolamento - Skid resistance - Rutschhemmung - Résistance au glissement Resistencia al deslizamiento - Сопротивление скольжению	DIGITAL TRIBOMETER (D-COF)		> 0,42 Naturale/Matt	> 0,42	ANSI 137.1:2012

- (a) Differenza ammissibile tra dimensione di fabbricazione e dimensione nominale - Permissible difference between work size and nominal size - Zulässige Differenz zwischen Werksmaß und Nennmaß - Différence admissible entre la dimension de fabrication et la dimension nominale - Diferencia admisible entre medida de fabricación y medida nominal - Допустимая разница между фактическим размером изделия и номинальным.
- (b) Deviazione ammissibile in % della dimensione media di una singola piastrella (2 o 4 lati) dalla dimensione di fabbricazione - Permissible % variation in the average size of a single tile (2 or 4 sides) from the work size - Zulässige Abweichung, in %, der mittleren Größe einer Einzeileise (2 oder 4 Seiten) vom Werksmaß - Déviation admissible en % de la dimension moyenne d'un seul carreau (2 ou 4 côtés) par rapport à la dimension de fabrication - En porcentaje, desviación admisible del tamaño medio de un solo azulejo (2 o 4 lados) con respecto a la medida de fabricación - Допустимое отклонение в % среднего размера каждой плитки (2 или 4 стороны) от фактических размеров.
- (c) c.c. Deviazione massima ammissibile della curvatura del centro, in % oppure mm, in rapporto alla diagonale calcolata secondo le dimensioni di fabbricazione | e.c. Deviazione massima ammissibile della curvatura dello spigolo, in % oppure mm, in rapporto alle dimensioni di fabbricazione corrispondenti | w. Deviazione massima ammissibile dello svergolamento, in % oppure mm, in rapporto alla diagonale calcolata secondo le dimensioni di fabbricazione - c.c. Maximum permissible deviation, in % or mm, in the centre curvature from the diagonal calculated on the basis of the work size | e.c. Maximum permissible deviation, in % or mm, from the diagonal calculated on the basis of the work size - c.c. Maximal zulässige Abweichung der Mittelpunktwölbung, in % oder mm, bezogen auf die über das Werksmaß berechnete Diagonale | e.c. Maximal zulässige Abweichung der Kantenwölbung, in % oder mm, bezogen auf das zugehörige Werksmaß | w. Maximal zulässige Abweichung der Windschiefe, in% oder mm, bezogen auf die über das Werksmaß berechnete Diagonale - c.c. Déviation maximale admissible de la courbure du centre, en % ou en mm, par rapport à la diagonale calculée selon les dimensions de fabrication | e.c. Déviation maximale admissible de la courbure de l'angle, en % ou en mm, par rapport aux dimensions de fabrication correspondantes | w. Déviation maximale admissible du voile en % ou en mm, par rapport à la diagonale calculée selon les dimensions de fabrication - c.c. En porcentaje o en milímetros, desviación máxima admisible de la curvatura del centro con respecto a la diagonal calculada según las medidas de fabricación | e.c. En porcentaje o en milímetros, desviación máxima admisible de la curvatura de la esquina con respecto a las medidas de fabricación correspondientes | w. En porcentaje o en milímetros, desviación máxima admisible del abarquillamiento con respecto a la diagonal calculada según las medidas de fabricación - c.c. Максимальное допустимое отклонение изгиба центра в % или в мм относительно диагонали, рассчитанное по фактическим размерам | e.c. Максимальное допустимое отклонение изгиба кромок в % или в мм по отношению к соответствующим фактическим размерам | w. Максимальное допустимое отклонение перекоса в % или в мм по отношению к диагонали, рассчитанное по фактическим размерам.
- \* Pavimentazioni di ambienti lavorativi e zone operative con superfici sdrucciolevoli. - Flooring of work environments and operating areas with slippery surface. - Bodenbeläge für Arbeitsräume und Arbeitsbereiche mit Rutschgefahr. - Sols de locaux industriels et de zones de travail à surfaces dérapantes. - Pavimentaciones de zonas de trabajo y operativas con superficies resbaladizas. - Полы в рабочих помещениях и рабочих зонах со скользкими полами. - Холостям.
- \*\* Pavimentazioni per zone bagnate con calpestio a piedi scalzi. - Flooring for wet areas to be walked on barefoot. - Bodenbeläge in nassbelasteten Barfußbereichen. - Sols pour zones mouillées avec piétinement pieds nus. - Pavimentaciones para zonas mojadas donde se camina con pies descalzos. - Полы для влажных зон, предназначенные для хождения по ним босиком.

TECHNICAL CHARACTERISTICS **CARATTERISTICHE TECNICHE**

technische eigenschaften - caracteristiques technique - datos tecnicos - технические характеристики

**MAIORA**  
Concrete Effect

I dati riportati sulla tabella tecnica si riferiscono solo ai fondi. / Technical chart data refer to plain tiles only. / Die technischen Daten beziehen sich nur auf die Grundfliesen. / Les données figurant dans le tableau technique se rapportent uniquement aux fonds. / Los datos que figuran en la tabla técnica se refieren únicamente a los fondos. / Данные, приведенные в технической таблице, относятся лишь только к фоновой плитке.

CARATTERISTICA CHARACTERISTIC EIGENSCHAFTEN CARACTERISTIQUE CARACTERÍSTICA ХАРАКТЕРИСТИКА	METODO DI PROVA TESTING METHOD PRÜFMETHODE MÉTHODE D'ESSAI MÉTODO DE PRUEBA МЕТОД ИСПЫТАНИЯ	UNITA DI MISURA MEASUREMENT UNIT MABEINHEIT UNITE DE MESURE UNIDAD DE MEDIDA ЕДИНИЦА ИЗМЕРЕНИЯ	VALORI TIPICI MEDI AVERAGE TYPICAL VALUES TYPISCHE DURCHSCHNITTSWERTE VALEURS MOYENNES TYPIQUES VALORES TÍPICOS MEDIOS ТИПОВЫЕ ЗНАЧЕНИЯ	VALORI LIMITE PREVISTI ESTABLISHED LIMITS VORGEGEHENE GRENZWERTE VALEURS LIMITES PREVUES VALORES LIMITE PREVISTOS ПРЕДУСМОТРЕННЫЕ ПРЕДЕЛЬНЫЕ ЗНАЧЕНИЯ	NORMA DI RIFERIMENTO REFERENCE STANDARD BEZUGSNORM NORME DE REFERENCES NORMA DE REFERENCIA СТАНДАРТ ДЛЯ СРАВКИ	
Tolleranze dimensionali Dimensions - Abmessungen Dimensions - Dimensiones Размерные допуски	ISO 10545_2	mm %	Conforme Compliant Konform Conforme Conforme Соответствует	UNI EN 14411-G		
Lunghezza e larghezza Length and width Länge und Breite Longueur et largeur Longitud y anchura Длина и ширина						N ≥ 15
Ortogonalità - Rectangularity Rechtwinkligkeit - Orthogonalité Ortogonalidad - Ортогональность						(a) ± 2% (max 5 mm) ± 2% (max 5 mm)
Spessore - Thickness Stärke - Epaisseur Espesor - Толщина						(b) ± 0,6% ± 2,0 mm
Rettilinearità degli spigoli Edge straightness Rechtlinigkeit der Kanten Rectitude des arêtes Rectitud de las esquinas Плосколинейность Кромки						± 0,5% ± 2,0 mm
Planarità - Flatness Ebenförmigkeit - Planéité Planeidad - Плоскостность						
Aspetto - Appearance Aspekt - Aspect Aspecto - Внешний вид						
Assorbimento d'acqua Water absorption Wasseraufnahme Absorption d'eau Absorción de agua Водопоглощение	ISO 10545_3	%		≤ 0,5		
Resistenza alla flessione Resistance to bending Biegefestigkeit Résistance à la flexion Resistencia a la flexión Сопротивление изгибу	ISO 10545_4	N/mm²		R ≥ 35 Valore singolo minimo 32 Minimum single value 32 Geringer Einzelwert 32 Valeur unique minimale 32 Valor unico minimo 32 Минимальное отдельное значение 32	UNI EN 14411-G	
Modulo di rottura Modulus of rupture Bruchlast - Module de rupture Módulo de rotura Предел прочности при разрыве						
Sforzo di rottura Breaking strength Bruchkraft Force de Rupture Esfuerzo de rotura Разрывное усилие	ISO 10545_4	N		≥ 700	UNI EN 14411-G	
Resistenza all'abrasione profonda Resistance to deep abrasion Tiefenabriebfestigkeit Résistance à l'abrasion profonde Resistencia a la abrasión profunda Устойчивость к глубокому истиранию	ISO 10545_6	mm³		120-150	UNI EN 14411-G	
Resistenza all'abrasione superficiale Resistance to surface abrasion Abriebfestigkeit Résistance à l'abrasion superficielle Resistencia a la abrasión superficial Стойкость к поверхностному истиранию	metodo interno internal method Interne Methode méthode interne método interno внутренний метод	classe interna internal class Interne Klassifizierung classe interne classe interna внутренний класс			UNI EN 14411-G	
Resistenza al gelo Frost resistance Frostbeständigkeit Résistance au gel Resistencia al helado Морозостойкость	ISO 10545_12		Conforme Compliant Konform Conforme Conforme Соответствует	Prova superata secondo la EN ISO 10545-1 - Test passed in accordance with EN ISO 10545-1 - Prüfung gemäß EN ISO 10545-1 bestanden - Essai réussi conformément à la norme EN ISO 10545-1 - Prueba superada de conformidad con la EN ISO 10545-1 - Испытание пройдено в соответствии со стандартом EN ISO 10545-1	UNI EN 14411-G	
Resistenza agli sbalzi termici Thermal shock resistance Widerstandsfähigkeit Temperaturschwankungen Résistance aux chocs thermiques Resistencia al choque térmico Стойкость к тепловым колебаниям	ISO 10545_9		Conforme Compliant Konform Conforme Conforme Соответствует	Prova superata secondo la EN ISO 10545-1 - Test passed in accordance with EN ISO 10545-1 - Prüfung gemäß EN ISO 10545-1 bestanden - Essai réussi conformément à la norme EN ISO 10545-1 - Prueba superada de conformidad con la EN ISO 10545-1 - Испытание пройдено в соответствии со стандартом EN ISO 10545-1	UNI EN 14411-G	
Coefficiente di dilatazione termica lineare Coefficient of linear thermal expansion Linearer Wärmeausdehnungs-Koeffizient Coefficient lineaire de dilatation thermique Coeficiente de dilatación térmica lineal Коэффициент линейного теплового расширения	ISO 10545_8	X10 <sup>-4</sup> /°C		≤ 9	UNI EN 14411-G	

CARATTERISTICA CHARACTERISTIC EIGENSCHAFTEN CARACTERISTIQUE CARACTERÍSTICA ХАРАКТЕРИСТИКА	METODO DI PROVA TESTING METHOD PRÜFMETHODE MÉTHODE D'ESSAI MÉTODO DE PRUEBA МЕТОД ИСПЫТАНИЯ	UNITA DI MISURA MEASUREMENT UNIT MABEINHEIT UNITE DE MESURE UNIDAD DE MEDIDA ЕДИНИЦА ИЗМЕРЕНИЯ	VALORI TIPICI MEDI AVERAGE TYPICAL VALUES TYPISCHE DURCHSCHNITTSWERTE VALEURS MOYENNES TYPIQUES VALORES TÍPICOS MEDIOS ТИПОВЫЕ ЗНАЧЕНИЯ	VALORI LIMITE PREVISTI ESTABLISHED LIMITS VORGEGEHENE GRENZWERTE VALEURS LIMITES PREVUES VALORES LIMITE PREVISTOS ПРЕДУСМОТРЕННЫЕ ПРЕДЕЛЬНЫЕ ЗНАЧЕНИЯ	NORMA DI RIFERIMENTO REFERENCE STANDARD BEZUGSNORM NORME DE REFERENCES NORMA DE REFERENCIA СТАНДАРТ ДЛЯ СРАВКИ
Resistenza alle macchie Resistance to staining Beständigkeit gegen Fleckenbildner Résistance aux produits tachants Resistencia a las manchas Стойкость к пятнообразованию	ISO 10545_14		classe 5 class 5 klasse 5 classe 5 categoria 5 класс 5	classe 3 minimo class 3 minimum Mind. klasse 3 classe 3 minimum categoria 3 minimo минимум класс 3	UNI EN 14411-G
Resistenza ai prodotti chimici di uso domestico e sali per piscina Resistance to chemicals for household use and swimming pool salts Beständigkeit gegen Haushaltschemikalien und Zusätze für Schwimmbäder Résistance aux produits chimiques d'usage domestique et sels pour piscine Resistencia a los productos químicos para uso doméstico y sales para piscina Устойчивость к бытовым химическим средствам и солям для бассейнов	ISO 10545_13		A	B minimo B minimum Mind. B B minimum B minimo Минимальный B	UNI EN 14411-G
Resistenza agli acidi e alle basi Resistance to acids and bases Säure- und Laugenfestigkeit Résistance aux acides et aux bases Resistencia a los ácidos y a las bases Стойкость к кислотам и щелочам			LA - LB HA - HB	Valore dichiarato Value declared Erklärter wert Valeur déclarée Valor declarado Заявленное значение	UNI EN 14411-G
Resistenza dei colori alla luce Colour resistance to light exposure Farblichkeit unter Lichteinfluss Résistance des couleurs à la lumière Resistencia de los colores a la exposición de la luz Светостойкость цветов	DIN 51094		Conforme Compliant Konform Conforme Conforme Соответствует	Non devono presentare apprezzabili alterazioni di colore - No sample must show noticeable colour modifications - Aucun échantillon ne doit présenter d'alterations appréciables de couleur - Kein Muster darf sichtbare Farbveränderungen aufweisen - Ninguna muestra ha de presentar alteraciones apreciables de color - Ни один из образцов не должен иметь значимых изменений цветов	
Resistenza allo scivolamento - Skid resistance - Rutschhemmung - Résistance au glissement Resistencia al deslizamiento - Скользящие свойства	RAMP METHOD		R10	da R9 a R13 - from R9 to R13 - von R9 bis R13 - de R9 à R13 - de R9 a R13 - от R9 до R13	DIN 51130 BGR 181*
Coefficiente di attrito medio Mean coefficient of friction Mittlerer Reibungskoeffizient Coefficient de frottement moyen Coefficient de roce medio Средний коэффициент трения	B.C.R.		μ > 0,40	μ > 0,40	D.M. N°236 14/6/1989
Resistenza allo scivolamento - Skid resistance - Rutschhemmung - Résistance au glissement Resistencia al deslizamiento - Скользящие свойства	PENDULUM		classe 1 - classe 1 - classe 1 - classe 1 - categoria 1 - класс 1		ENV 12633 BOE N°74 del 2006
Resistenza allo scivolamento Skid resistance Rutschhemmung Résistance au glissement Resistencia al deslizamiento Скользящие свойства	PENDULUM		PTV > 36 (slider 96)	0 - 24 Scivoloso - Slippery - Rutschig - Glissant - Resbaladizo - Скользящий 25 - 35 Scivolosità moderata - Moderately slippery - Mäßige Rutschgefahr - Glissance modérée - Deslizamiento moderado - Умеренная скользкость > 36 Basso rischio scivolamento - Low slipping risk - Geringe Rutschgefahr - Risque de glissement faible - Bajo riesgo de deslizamiento - Низкий риск скольжения	BSEN13036-4:2011
Resistenza allo scivolamento - Skid resistance - Rutschhemmung - Résistance au glissement Resistencia al deslizamiento - Скользящие свойства	DIGITAL TRIBOMETER (D-COF)		> 0,42	> 0,42	ANSI 137.1:2012

- (a) Differenza ammissibile tra dimensione di fabbricazione e dimensione nominale - Permissible difference between work size and nominal size - Zulässige Differenz zwischen Werksmaß und Nennmaß - Différence admissible entre la dimension de fabrication et la dimension nominale - Diferencia admisible entre medida de fabricación y medida nominal - Допустимая разница между фактическим размером изделия и номинальным.
  - (b) Deviazione ammissibile in % della dimensione media di una singola piastrella (2 o 4 lati) dalla dimensione di fabbricazione - Permissible % variation in the average size of a single tile (2 or 4 sides) from the work size - Zulässige Abweichung, in %, der mittleren Größe einer Einzelfliese (2 oder 4 Seiten) vom Werksmaß - Déviation admissible en % de la dimension moyenne d'un seul carreau (2 ou 4 côtés) par rapport à la dimension de fabrication - En porcentaje, desviación admisible del tamaño medio de un solo azulejo (2 o 4 lados) con respecto a la medida de fabricación - Допустимое отклонение в % среднего размера каждой плитки (2 или 4 стороны) от фактических размеров.
  - (c) c.c. Deviazione massima ammissibile della curvatura del centro, in % oppure mm, in rapporto alla diagonale calcolata secondo le dimensioni di fabbricazione | e.c. Deviazione massima ammissibile della curvatura dello spigolo, in % oppure mm, in rapporto alle dimensioni di fabbricazione corrispondenti | w. Deviazione massima ammissibile dello svergolamento, in % oppure mm, in rapporto alla diagonale calcolata secondo le dimensioni di fabbricazione - c.c. Maximum permissible deviation, in % or mm, in the centre curvature of the diagonal calculated on the basis of the work size | e.c. Maximum permissible deviation, in % or mm, from the diagonal calculated on the basis of the work size - c.c. Maximal zulässige Abweichung der Mittelpunktwölbung, in % oder mm, bezogen auf die über das Werksmaß berechnete Diagonale | e.c. Maximal zulässige Abweichung der Kantenwölbung, in % oder mm, bezogen auf das zugehörige Werksmaß | w. Maximal zulässige Abweichung der Windschiefe, in% oder mm, bezogen auf die über das Werksmaß berechnete Diagonale - c.c. Déviation maximale admissible de la courbure du centre, en % ou en mm, par rapport à la diagonale calculée selon les dimensions de fabrication | e.c. Déviation maximale admissible de la courbure de l'angle, en % ou en mm, par rapport à la diagonale calculée selon les dimensions de fabrication - c.c. En porcentaje o en milímetros, desviación máxima admisible de la curvatura del centro con respecto a la diagonal calculada según las medidas de fabricación | e.c. En porcentaje o en milímetros, desviación máxima admisible de la curvatura de la esquina con respecto a las medidas de fabricación correspondientes | w. En porcentaje o en milímetros, desviación máxima admisible del abarquillamiento con respecto a la diagonal calculada según las medidas de fabricación - c.c. Максимальное допустимое отклонение изгиба центра в % или в мм относительно диагонали, рассчитанное по фактическим размерам | e.c. Максимальное допустимое отклонение изгиба кромок в % или в мм по отношению к соответствующим фактическим размерам | w. Максимальное допустимое отклонение перегиба в % или в мм по отношению к диагонали, рассчитанное по фактическим размерам.
- \* Pavimentazioni di ambienti lavorativi e zone operative con superfici sdrucciolevoli. - Flooring of work environments and operating areas with slippery surface. - Bodenbeläge für Arbeitsräume und Arbeitsbereiche mit Rutschgefahr. - Sols de locaux industriels et de zones de travail à surfaces dérapantes. - Pavimentaciones de zonas de trabajo y operativas con superficies resbaladizas. - Полы в рабочих помещениях и рабочих зонах со скользкими поверхностями.
- \*\* Pavimentazioni per zone bagnate con calpestio a piedi scalzi. - Flooring for wet areas to be walked on barefoot. - Bodenbeläge in nassbelasteten Barfußbereichen. - Sols pour zones mouillées avec piétinement pieds nus. - Pavimentaciones para zonas mojadas donde se camina con pies descalzos. - Полы для влажных зон, предназначенные для хождения по ним босиком.

Per ordini di due o più articoli nello stesso formato - o anche in formati differenti purché modulari - si raccomanda di riporre le lastre in un'unica cassa, fino al suo riempimento.

È opportuno spedire le casse in condizioni di massimo carico.

Cassa per lastre 120x120	Cassa per lastre 120x240	Cassa per lastre 120x278
<b>Cassa in legno</b> (Pz sfusi) dimensioni cm 139 x 139 x 38h - Mq lastra 1,44 - Kg lastra 22,95 - Lastre per cassa 24 - Mq per cassa 34,56 - Kg cassa piena 632	<b>Cassa in legno</b> (Pz sfusi) dimensioni cm 139 x 266 x 41h - Mq lastra 2,88 - Kg lastra 45,90 - Lastre per cassa 20 - Mq per cassa 57,60 - Kg cassa piena 1021	<b>Cassa in legno</b> (Pz sfusi) dimensioni cm 140 x 291 x 41h - Mq lastra 3,34 - Kg lastra 52,99 - Lastre per cassa 18 - Mq per cassa 60,05 - Kg cassa piena 1074

For orders for two or more articles in the same size - or in multiple modular sizes - slabs must be placed in the same crate, until full.  
Crates should be shipped filled to capacity.

Crate for slabs of 120x120	Crate for slabs of 120x240	Crate for slabs of 120x278
<b>Wooden crate</b> (Loose pcs) dimensions 139 x 139 x 38h - Slab area 1.44 m <sup>2</sup> - Slab weight 22.95 kg - Slabs per crate 24 - M <sup>2</sup> per crate 34.56 - Weight of full crate 632 kg	<b>Wooden crate</b> (Loose pcs) dimensions 139 x 266 x 41h - Slab area 2.88 m <sup>2</sup> - Slab weight 45.90 kg - Slabs per crate 20 - M <sup>2</sup> per crate 57.60 - Weight of full crate 1021 kg	<b>Wooden crate</b> (Loose pcs) dimensions 140 x 291 x 41h - Slab area 3.34 m <sup>2</sup> - Slab weight 52.99 kg - Slabs per crate 18 - M <sup>2</sup> per crate 60.05 - Weight of full crate 1074 kg

Für Bestellungen von einem oder mehreren Artikeln desselben Formats - oder auch mehrerer, jedoch modularer Formate - wird empfohlen, die Platten in einer einzigen Kiste zu verpacken, bis diese gefüllt ist.

Es wird empfohlen, die Kisten vollbeladen zu versenden.

Kiste für Platten 120x120	Kiste für Platten 120x240	Kiste für Platten 120x278
<b>Holz-kiste</b> (Losgut) Abmessungen 139 x 139 x H38 cm - Plattenfläche 1,44 m <sup>2</sup> - Plattengewicht 22,95 kg - Platten pro Kiste 24 - Fläche pro Kiste 34,56 m <sup>2</sup> - Vollst. beladene Kiste 632 kg	<b>Holz-kiste</b> (Losgut) Abmessungen 139 x 266 x H41 cm - Plattenfläche 2,88 m <sup>2</sup> - Plattengewicht 45,90 kg - Platten pro Kiste 20 - Fläche pro Kiste 57,60 m <sup>2</sup> - Vollst. beladene Kiste 1021 kg	<b>Holz-kiste</b> (Losgut) Abmessungen 140 x 291 x H41 cm - Plattenfläche 3,34 m <sup>2</sup> - Plattengewicht 52,99 kg - Platten pro Kiste 18 - Fläche pro Kiste 60,05 m <sup>2</sup> - Vollst. beladene Kiste 1074 kg

Pour des commandes de deux ou plusieurs articles du même format (ou de formats différents, à condition d'être modulaires), il est recommandé de mettre les dalles dans une seule caisse jusqu'à que qu'elle soit pleine.

Il convient d'expédier des caisses chargées au maximum.

Caisse pour dalles de 120x120	Caisse pour dalles de 120x240	Caisse pour dalles de 120x278
<b>Caisse en bois</b> (Pièces en vrac) dimensions 139 cm x 139 cm x h38 cm - Dalle 1,44 m <sup>2</sup> - Dalles par caisse 24 - m <sup>2</sup> par caisse 34,56 - Caisse pleine 632 kg	<b>Caisse en bois</b> (Pièces en vrac) dimensions 139 cm x 266 cm x h41 cm - Dalle 2,88 m <sup>2</sup> - Dalles par caisse 20 - m <sup>2</sup> par caisse 57,60 - Caisse pleine 1021 kg	<b>Caisse en bois</b> (Pièces en vrac) dimensions 140 cm x 291 cm x h41 cm - Dalle 3,34 m <sup>2</sup> - Dalles par caisse 18 - m <sup>2</sup> par caisse 60,05 - Caisse pleine 1074 kg

En el caso de pedidos de dos o más artículos del mismo formato -o también de formatos diferentes, pero modulares- se recomienda embalar las placas en una única caja, hasta llenarla por completo.

Resulta oportuno transportar las cajas en condiciones de carga máxima.

Caja para placas de 120 x 120 cm	Caja para placas de 120 x 240 cm	Caja para placas de 120 x 278 cm
<b>Caja de madera</b> (Piezas sueltas) medidas de 139 x 139 x 38 h cm - placa 1,44 m <sup>2</sup> - placa 22,95 kg - 24 placas en cada caja grande - 34,56 m <sup>2</sup> por caja grande - Caja grande llena 632 kg	<b>Caja de madera</b> (Piezas sueltas) medidas de 139 x 266 x 41 h cm - placa 2,88 m <sup>2</sup> - placa 45,90 kg - 20 placas en cada caja grande - 57,60 m <sup>2</sup> por caja grande - Caja grande llena 1021 kg	<b>Caja de madera</b> (Piezas sueltas) medidas de 140 x 291 x 41 h cm - placa 3,34 m <sup>2</sup> - placa 52,99 kg - 18 placas en cada caja grande - 60,05 m <sup>2</sup> por caja grande - Caja grande llena 1074 kg

При заказе двух или более артикулов одного формата, а также разных, но кратных форматах, рекомендуется упаковывать плиты в один ящик, вплоть до его заполнения.

Рекомендуется отправлять максимально заполненные ящики.

Ящик для плит 120 x 120	Ящик для плит 120 x 240	Ящик для плит 120 x 278
<b>Деревянный ящик</b> (Изделия россыпью) размеры 139 x 139 x В. 38 см - Площадь плиты: 1,44 кв.м. - Вес плиты: 22,95 кг - Плит в ящике: 24 шт. - Кв.м. в ящике: 34,56 - Вес полного ящика: 632 кг	<b>Деревянный ящик</b> (Изделия россыпью) размеры 139 x 266 x В. 41 см - Площадь плиты: 2,88 кв.м. - Вес плиты: 45,90 кг - Плит в ящике: 20 шт. - Кв.м. в ящике: 57,60 - Вес полного ящика: 1021 кг	<b>Деревянный ящик</b> (Изделия россыпью) размеры 140 x 291 x В. 41 см - Площадь плиты: 3,34 кв.м. - Вес плиты: 52,99 кг - Плит в ящике: 18 шт. - Кв.м. в ящике: 60,05 - Вес полного ящика: 1074 кг

L'utilizzo dei cavalletti avviene solo su richiesta del cliente.

Per ordini di due o più articoli nello stesso formato - o anche in formati differenti purché modulari - si raccomanda di riporre le lastre in un unico cavalletto, fino al suo riempimento.

È opportuno spedire i cavalletti in condizioni di massimo carico.

<b>Cavalletto</b> (Pz sfusi) - 120x240 dimensioni cm 75 x 250 x 160h - Mq lastra 2,88 - Kg lastra 45,90 - Lastre per cavalletto 40 - Mq per cavalletto 115,20 - Kg cavalletto pieno 2006	<b>Cavalletto</b> (Pz sfusi) - 120x278 dimensioni cm 75 x 290 x 160h - Mq lastra 3,34 - Kg lastra 52,99 - Lastre per cavalletto 36 - Mq per cavalletto 120,10 - Kg cavalletto pieno 2088
--	--

A-frames are only used when requested by the customer.

For orders for two or more articles in the same size - or in multiple modular sizes - slabs must be placed in the same A-frame, until full.

A-frames should be shipped filled to capacity.

<b>A-Frame</b> (Loose pcs) - 120x240 dimensions 75 x 250 x 160h cm - Slab area 2.88 m <sup>2</sup> - Slab weight 45.90 kg - Slabs per A-frame 40 - M <sup>2</sup> per A-frame 115.20 - Weight of full A-frame 2006 kg	<b>A-Frame</b> (Loose pcs) - 120x278 dimensions 75 x 290 x 160h cm - Slab area 3.34 m <sup>2</sup> - Slab weight 52.99 kg - Slabs per A-frame 36 - M <sup>2</sup> per A-frame 120.10 - Weight of full A-frame 2088 kg
---	---

Die Verpackung in Transportgestellen erfolgt nur auf Anfrage des Kunden.

Für Bestellungen von einem oder mehreren Artikeln desselben Formats - oder auch mehrerer, jedoch modularer Formate - wird empfohlen, die Platten in einem einzigen Transportgestell zu verpacken, bis dieses gefüllt ist.

Es wird empfohlen, die Transportgestelle vollbeladen zu versenden.

<b>Transportgestell</b> (Losgut) - 120x240 Abmessungen 75 x 250 x H160 cm - Plattenfläche 2,88 m <sup>2</sup> - Plattengewicht 45,90 kg - Platten pro Transportgestell 40 - Fläche pro Transportgestell 115,20 m <sup>2</sup> - Vollst. beladenes Transportgestell 2006 kg	<b>Transportgestell</b> (Losgut) - 120x278 Abmessungen 75 x 290 x H160 cm - Plattenfläche 3,34 m <sup>2</sup> - Plattengewicht 52,99 kg - Platten pro Transportgestell 36 - Fläche pro Transportgestell 120,10 m <sup>2</sup> - Vollst. beladenes Transportgestell 2088 kg
--	--

L'utilisation des chevalets de transport n'est effectuée qu'à la demande du client.

Pour des commandes de deux ou plusieurs articles du même format (ou de formats différents, à condition d'être modulaires), il est recommandé de mettre les dalles sur un seul chevalet jusqu'à que qu'il soit plein.

Il convient d'expédier des chevalets chargés au maximum.

<b>Chevalet de transport</b> (Pièces en vrac) 120x240 dimensions 75 cm x 250 cm x h160 cm - Dalle 2,88 m <sup>2</sup> - Dalle 45,90 kg - Dalles par chevalet de transport 40 - m <sup>2</sup> par chevalet de transport 115,20 - Chevalet de transport plein 2006 kg	<b>Chevalet de transport</b> (Pièces en vrac) - 120x278 dimensions 75 cm x 290 cm x h160 cm - Dalle 3,34 m <sup>2</sup> - Dalle 52,99 kg - Dalles par chevalet de transport 36 - m <sup>2</sup> par chevalet de transport 120,10 - Chevalet de transport plein 2088 kg
--	--

Se usarán caballetes solamente si así lo solicita el cliente.

En el caso de pedidos de dos o más artículos del mismo formato -o también de formatos diferentes, pero modulares- se recomienda embalar las placas en un único caballete, hasta llenarlo por completo.

Resulta oportuno transportar los caballetes en condiciones de carga máxima.

<b>Caballete</b> (Piezas sueltas) - 120x240 medidas 75 x 250 x 160 h cm - placa 2,88 m <sup>2</sup> - placa 45,90 kg - 40 placas por caballete - 115,20 m <sup>2</sup> por caballete - Caballete lleno 2006 kg	<b>Caballete</b> (Piezas sueltas) - 120x278 medidas 75 x 290 x 160 h cm - placa 3,34 m <sup>2</sup> - placa 52,99 kg - 36 placas por caballete - 120,10 m <sup>2</sup> por caballete - Caballete lleno 2088 kg
--	--

Упаковка на подставках осуществляется лишь только по заказу клиента.

При заказе двух или более артикулов одного формата, а также разных, но кратных форматах, рекомендуется размещать плиты на одной подставке, вплоть до ее заполнения.

Рекомендуется отправлять максимально заполненные подставки.

<b>Подставка</b> (Изделия россыпью) - 120x240 размеры 75 x 250 x В. 160 см - Площадь плиты: 2,88 кв.м. - Вес плиты: 45,90 кг - Плит на подставке: 40 шт. - Кв.м. на подставке: 115,20 - Вес полной подставки: 2006 кг.	<b>Подставка</b> (Изделия россыпью) - 120x278 размеры 75 x 290 x В. 160 см - Площадь плиты: 3,34 кв.м. - Вес плиты: 52,99 кг - Плит на подставке: 36 шт. - Кв.м. на подставке: 120,10 - Вес полной подставки: 2088 кг.
--	--

ADVICE FOR LAYING AND MAINTENANCE **CONSIGLI DI POSA E MANUTENZIONE**  
verlegungs- und Pflegehinweise - conseils pour la pose et l'entretien  
consejos de colocación y mantenimiento - рекомендации по укладке и уходу EN

#### POSA IN OPERA

Prima di iniziare le operazioni di posa di una qualsiasi superficie si raccomanda di accertarsi che la partita di materiale sia adeguata e sufficiente per quantità, tono e calibro, a quella necessaria. Si dovranno poi seguire tutte le norme e le precauzioni che sono alla base di una corretta esecuzione del lavoro (preparazione del sottofondo, composizione della malta o dei collanti, rispetto dei tempi di essiccazione, posizionamento dei giunti di dilatazione, battitura, ecc...).

#### POSA CON ADESIVI

- La posa deve essere effettuata da personale qualificato con l'ausilio di attrezzi adeguati.
- La superficie su cui si effettua la posa (massetto) deve essere perfettamente piana. Valore massimo consigliato non superiore a 3 mm. per un dislivello determinato sotto un regolo di 2 m.
- La superficie su cui si effettua la posa deve essere ben stagionata, priva di polvere e di fessurazioni visibili.
- Durante l'operazione di posa è vivamente consigliato l'utilizzo di un'adeguata illuminazione.
- La scelta dell'adesivo è condizionata dalla tipologia delle piastrelle (gruppo di appartenenza e formato), dal tipo di superficie da rivestire e dalla sua destinazione d'uso.
- E' opportuno verificare la posa del materiale prima che il collante sia secco, per facilitare eventuali correzioni.

#### POSA CON MALTA FRESCA

La posa a malta cementizia fresca o "strato spesso" è sconsigliata per formati aventi lato > 30 cm e con supporti non assorbenti.

#### REALIZZAZIONE DEI GIUNTI

I giunti sono elementi molto importanti per il mantenimento di una buona superficie piastrellata e si consiglia di avvalersi della collaborazione e/o consulenza di un posatore professionista. Si declina ogni responsabilità per la posa senza fuga; si considera posa a "giunto minimo" quella con fuga a 2 mm.

I giunti devono essere posizionati:

- su raccordi strutturali (giunti strutturali)
- tra suolo e parete (giunti perimetrali)
- tra una piastrella e l'altra (giunti di posa o fuga)
- tra piastrelle ed altri materiali (es. accostamento ceramica / linoleum / legno).

#### STUCCATURA SUPERFICIE POSATA

Prima di realizzare le fughe è consigliabile attendere fino a completa asciugatura del collante e assicurarsi che i giunti di posa siano vuoti e liberi da ogni traccia di collante e/o polveri.

- Stuccare piccole superfici per volta (4-5 mq). Questo è da tenere in particolare considerazione per prodotti strutturati, antiscivolo e levigati.
- Eliminare l'eccesso di fugante dalla superficie con movimenti diagonali quando il prodotto è ancora umido e togliere tutti i residui, in particolar modo per le superfici da esterno.
- Pulire accuratamente con una spugna bagnata in acqua limpida e pulita e ripassare con straccio umido su tutta la superficie, fughe comprese.
- Per fughe in netto contrasto cromatico con le piastrelle posate è consigliabile testare il fugante su un'area circoscritta e nascosta.
- Per gli stucchi epossidici si raccomanda la pulizia con spugna e abbondante acqua. La velocità di reazione e indurimento di questi prodotti rende impossibile la rimozione dei residui successivamente all'indurimento. Il giorno dopo la stuccatura effettuare una pulizia completa con detergente alcalino.
- Si consiglia di consultare i produttori di materiale fugante per verificare la scelta corretta della fuga rispetto al tipo di piastrella.

#### PULIZIA E MANUTENZIONE DOPO LA POSA

Un cantiere si può considerare completamente finito quando è sgombro da qualunque utensile/materiale derivante dalle lavorazioni. Per ridurre i rischi di danneggiamento della superficie piastrellata, è necessario proteggerla ed evitare il più possibile la presenza di materiali abrasivi (polveri o residui da lavorazioni successive).

#### PULIZIA INIZIALE

Il lavaggio dopo la posa è una fase di fondamentale importanza per tutti gli interventi successivi e per una corretta manutenzione.

Un accurato lavaggio iniziale permette ai pavimenti di restare belli e protetti a lungo e si esegue normalmente una sola volta prima dell'utilizzo del pavimento. Si raccomanda di effettuare la pulizia iniziale dopo 4-5 giorni e non più tardi di 10, dalla posa e stuccatura della superficie.

La superficie fugata e pulita può presentare un film di residui cementizi che non sono asportabili con sola acqua per cui si rende necessario l'utilizzo di un prodotto a base acida, opportunamente diluito (diluizione da 1:10 a 1:4 in acqua fredda), in base a quanto dichiarato dal produttore.

La prima operazione da eseguire è quella di bagnare la superficie piastrellata ed in particolare le fughe (di norma non resistenti agli acidi). Spargere la soluzione acida preparata e lasciare agire per un breve tempo (2 min). Non lasciare asciugare il prodotto applicato.

Procedere alla rimozione della soluzione aiutandosi con una macchina monospazzola (disco non abrasivo), aspiraliquidi, altri mezzi e/o manualmente e alla fine risciacquare abbondantemente.

E' importante sottolineare che la pulizia eseguita con macchine (particolarmente consigliata per prodotti strutturati e per grandi superfici), va sempre completata manualmente nei punti difficilmente raggiungibili, soprattutto negli angoli, lungo le pareti dei locali e in ogni zona in cui la monospazzola non può operare.

E' sempre consigliabile testare la resistenza del prodotto agli acidi su un pezzo non posato o su una piccola porzione nascosta della superficie piastrellata; in particolare per prodotti lappati o levigati. L'uso di prodotti di pulizia contenenti acido fluoridrico (HF) e suoi derivati sono da evitare.

#### PULIZIA ORDINARIA

Gli interventi di pulizia ordinaria delle superfici hanno lo scopo di rimuovere lo sporco, cancellare i segni e ripristinare l'aspetto originale.

Le piastrelle in gres porcellanato smaltato non necessitano di trattamenti di protezione e una corretta e sistematica pulizia è sufficiente a mantenere inalterata la superficie.

Un'accurata pulizia deve essere fatta con un normale lavaggio con acqua calda, straccio/ spugna morbida ed eventualmente con l'utilizzo di detergenti neutri.

Per locali con grandi superfici possono essere utilizzate macchine industriali lavasciuga con completamento manuale dove necessario.

Raccomandazioni:

- evitare di strofinare le superfici con strumenti abrasivi, come pagliette in metallo o spazzole dure, che potrebbero lasciare graffi e segni indelebili;
- rimuovere eventuali residui grassi o oleosi con detergenti contenenti solventi organici o con detergenti alcalini (pH>9) e fare seguire un accurato risciacquo;
- evitare l'utilizzo di saponi in quanto tendono a lasciare uno strato viscido, in particolare se utilizzati in abbinamento ad acque dure;
- non utilizzare prodotti contenenti cere o brillantanti;
- evitare l'uso di detergenti abrasivi su superfici lucide e/o levigate; possono essere utilizzati su materiali matt., previa verifica su una piccola porzione piastrellata. In generale l'uso di qualunque detergente non neutro, deve essere preliminarmente testato su una piastrella non posata o su una porzione nascosta della pavimentazione.

#### CONSIGLI DI POSA A PAVIMENTO PER FORMATI RETTANGOLARI

Per i formati rettangolari, oltre alla posa ortogonale, si consiglia la posa a correre, regolare o irregolare, con una differenza tra pezzo e pezzo di:

- max 1/4 per formati: 15x90 - 10x120 - 15x120 - 20x120 - 30x120 - 60x120 - 58x116 - 29x116 -19,5x116 - 14,4x116
- max 1/3 per formati: 14,5x58 - 15x60 - 30x60 - 37,5x75 - 29x58 - 20x40

Per approfondimenti consultare il sito [www.ragno.it](http://www.ragno.it)

#### LAYING

Before laying on any surface, make sure that the material is appropriate and sufficient in terms of quantity, shade and work-size to suit the laying needs. All regulations and precautions concerning the correct execution of the works must be followed (preparing the bed, grout or adhesive composition, respect for drying times, position of the expansion joints, beating, etc....).

#### LAYING WITH ADHESIVES

- Laying must be done by qualified staff using appropriate equipment.
- The surface to be laid (screed) must be perfectly level. Maximum recommended value no more than 3 mm for an uneven surface measured with a 2 m ruler.
- The surface to be laid must be well seasoned, dust-free and with no visible cracks.
- During laying the use of appropriate lighting is strongly recommended.
- The choice of adhesive depends on the type of tile (type and size), the type of surface laid on and the type of foreseen use.
- Check that the tiles are laid correctly before the adhesive dries in order to facilitate any required corrections.

#### LAYING WITH FRESH MORTAR

Laying with fresh cement-based mortar or "thick layers" is not recommended for sizes more than 30 cm long and with non-absorbent supports.

#### JOINTS

Joints are very important elements for maintaining a good tiled surface, it is recommended to make use of the collaboration and/or advice of a professional layer. The company declines all responsibility for laying without joints; minimum joint laying has a gap of 2 mm.

The joints must be positioned:

- on structural joints;
- between the floor and the wall (perimeter joints);
- between one tile and another (laying joints);
- between the tiles and other materials (e.g. combinations of ceramics/linoleum / wood).

#### GROUTING LAID SURFACES

Before grouting wait for the adhesive to dry completely and make sure that the laying joints are empty and free of all traces of adhesive and/or dust.

- Grout small areas at a time (4-5 m2). This is particularly important for structured products, non-slip and polished surfaces.
- Remove excess grout from the tiles using diagonal movements when the product is still damp and remove all residues, particularly for external surfaces.
- Clean carefully using a sponge dampened in clean, limpid water and go over the whole surface, including the gaps, with a damp cloth.
- For grouting which has a strong colour contrast to the laid tiles, test the grout on a small, hidden area.
- When using epoxy grouts, clean with a sponge and plenty of water. The reaction and hardening times of these products make it impossible to remove any residues once they have hardened. The day after grouting, completely clean the surface with an alkaline detergent.
- Consult the grout manufacturers to verify the correct choice of grout for the type of tile.

#### CLEANING AND MAINTENANCE AFTER LAYING

Worksites are deemed to be completely finished once they have been cleared of all tools and materials used during the operations. To reduce the risk of damaging tiled surfaces, protect them and avoid the presence of abrasive materials (dust and residues from operations carried out after laying) as far as possible.

#### INITIAL CLEANING

Washing after laying is of fundamental importance to all operations carried out afterwards and to assure correct maintenance.

Careful initial cleaning keeps floors beautiful and protected longer and is done once only before using the floor.

Initial cleaning should be carried out 4-5 days after laying, and in any case no longer than 10 days after laying and grouting.

The grouted and cleaned surface may have a concrete film which cannot be removed using water alone, and therefore an acid-based product, suitably diluted (from 1:10 to 1:4 in cold water) should be used, following the manufacturer's instructions.

The first operation is to wet the tiled surface and particularly the gaps (grout is not usually acid-resistant). Spread the prepared acid solution and leave for a short time (2 minutes). Do not allow the applied product to dry.

Remove the solution using a brushing machine (with a non-abrasive disk), wet vac or other means and/or manually, then rinse well.

It should be remembered that machine cleaning (which is particularly recommended for textured products and large surfaces) must always be completed by hand in tight corners, along walls and any spaces that the brushing machine cannot easily reach.

It is always advisable to test the resistance of the product to acids on an unglazed tile or a small hidden surface; particularly for lapped or polished products. It is not recommended to use cleaning products containing hydrofluoric acid (HF) or its derivatives.

#### ORDINARY CLEANING

Ordinary cleaning removes dirt and marks and restores the surface to its original appearance.

Porcelain stoneware tiles do not require protective treatment, and a thorough, systematic clean is sufficient to maintain the surface.

Careful cleaning must be done by washing normally using hot water, a cloth or soft sponge and, if required, neutral detergents.

For large areas, industrial washing machines can be used, with completion by hand where required.

Recommendations:

- Do not rub the surfaces using abrasive tools, such as metallic sponges or hard brushes, which could scratch them or leave indelible marks;
- Grease and oil residues can be removed using detergents using organic or alkaline solvents (pH>9) followed by careful rinsing;
- Avoid the use of soap as this tends to leave a slimy layer, particularly when used with hard water;
- Do not use products containing wax or shining agents;
- Avoid the use of abrasive detergents on shiny and/or polished surfaces; they may be used on matt materials, checking first on a small hidden tiled area. Generally speaking, when using any non-neutral detergent, check first on an unglazed tile or a small hidden portion of the floor.

#### RECOMMENDATIONS FOR LAYING RECTANGULAR TILES AS A FLOOR COVERING

Apart from laying aligned in both directions, rectangular sizes should be laid in regular or irregular rows, or staggered rows with a distance between joints of:

- max 1/4 of a tile for sizes: 15x90 - 10x120 - 15x120 - 20x120 - 30x120 - 60x120 - 58x116 - 29x116 - 19,5x116 - 14,4x116
- max 1/3 of a tile for sizes: 14,5x58 - 15x60 - 30x60 - 37,5x75 - 29x58 - 20x40

For further details, visit [www.ragno.it](http://www.ragno.it)

## ADVICE FOR LAYING AND MAINTENANCE **CONSIGLI DI POSA E MANUTENZIONE**

verlegungs- und Pflegehinweise - conseils pour la pose et l'entretien

consejos de colocación y mantenimiento - рекомендации по укладке и уходу EN

### BAUSEITIGE VERLEGUNG

Stellen Sie, bevor Sie mit der Verlegung der Fliesen beginnen, sicher, dass die Materialpartie im Hinblick auf Menge, Farbton und Größenklasse die Anforderungen erfüllt und ausreicht. Es müssen außerdem alle Normen und Vorsichtsmaßnahmen eingehalten werden, die die Grundlage für eine korrekte Ausführung der Arbeiten darstellen (Vorbereitung des Untergrunds, Zusammensetzung des Mörtels oder der Kleber, Trocknungszeiten, Lage der Dehnungsfugen, Anklopfen usw....).

### VERLEGUNG MIT KLEBER

- Die Verlegung muss durch qualifiziertes Personal mit geeigneten Werkzeugen durchgeführt werden.
- Die Fläche, auf der die Verlegung erfolgt (Estrich) muss perfekt eben sein. Empfohlener maximaler Wert der Abweichung nicht über 3 mm beim Anlegen eines 2 m-langen Richtscheits.
- Die Fläche, auf der die Verlegung erfolgen soll, muss vollständig trocken und frei von Staub und sichtbaren Rissen sein.
- Während der Verlegung wird dringend empfohlen, eine ausreichende Beleuchtung zu gewährleisten.
- Die Wahl des Klebers hängt von der Art der Fliesen (Gruppe und Größe), von der Art der Oberfläche, auf der verlegt werden soll und vom Bestimmungszweck ab.
- Die Verlegung der Fliesen sollte überprüft werden, bevor der Kleber trocken ist, um Korrekturen zu ermöglichen.

### VERLEGUNG MIT FRISCHEM MÖRTEL

Die Verlegung mit frischem Zementmörtel oder „Dickbettverlegung“ wird für Formate empfohlen, deren Seitenmaße größer als 30 cm sind und die auf nicht absorbierenden Untergründen verlegt werden sollen.

### DIE VERFUGUNG

Die Fugen sind für den Erhalt einer guten Fliesenoberfläche sehr wichtig und wir empfehlen, dafür die Arbeit bzw. Beratung eines Fachmanns in Anspruch zu nehmen. Wir übernehmen keine Haftung für eine fugenlose Verlegung, unter einer Verlegung mit sehr schmalen Fugen versteht man die Verlegung von 2 mm breiten Fugen.

Die Fugen müssen positioniert werden:

- an strukturellen Anschlüssen (Strukturfugen)
- zwischen Boden und Wand (Randfugen)
- zwischen einer Fliese und der anderen (Verlegefugen oder Fugen)
- zwischen Fliesen und anderen Materialien (z.B. Kombination von Keramik/ Linoleum/Holz).

### VERFUGEN VERLEGTER OBERFLÄCHEN

Bevor die Fugen ausgeführt werden, wird empfohlen, zu warten, bis der Kleber komplett trocken ist. Stellen Sie sicher, dass die Verlegefugen leer und frei von jeglichen Spuren von Klebstoff und/oder Staub sind.

- Verfugen Sie jeweils kleine Flächen (4 - 5 m<sup>2</sup>). Dies gilt vor allem für strukturierte, rutschfeste und polierte Fliesen.
- Entfernen Sie die überschüssige Fugenmasse mit diagonalen Bewegungen von der Oberfläche aus, wenn das Produkt noch feucht ist und entfernen Sie, vor allem in Außenbereichen, alle Rückstände.
- Gründlich mit einem Schwamm, der in reinem und klarem Wasser befeuchtet wurde, reinigen und mit einem feuchten Tuch über die gesamte Fläche einschließlich der Fugen nachwischen.
- Für Fugen, die im eindeutigen Farbkontrast zu den verlegten Fliesen stehen, sollten Sie die Fugenmasse an einer begrenzten, verdeckten Fläche vorher testen.
- Für Epoxyd-Fugenmörtel wird die Reinigung mit einem Schwamm und sauberm Wasser empfohlen. Die schnelle Reaktion und das schnelle Härten dieser Produkte macht die Beseitigung von Rückständen nach dem Aushärten unmöglich. Am Tag nach der Verfugung ist eine gründliche Reinigung mit alkalischen Reinigungsmitteln erforderlich.
- Für die jeweilige Wahl der Fuge für die jeweilige Fliese wenden Sie sich bitte an den Hersteller des Fugenmittels.

### REINIGUNG UND PFLEGE NACH DER VERLEGUNG

Eine Baustelle ist erst vollständig beendet, wenn sie frei von jedem Arbeitsmaterial ist. Um die Gefahr der Beschädigung der Fliesenoberfläche zu senken, ist es notwendig, sie zu schützen und so weit wie möglich die Anwesenheit von abrasiven Materialien (Pulver oder Rückstände der weiteren Verarbeitung) zu vermeiden.

### GRUNDREINIGUNG

Die Grundreinigung nach der Verlegung ist wichtig, um die spätere Reinigung und Pflege zu ermöglichen.

Eine sorgfältige Grundreinigung sorgt dafür, dass die Böden lange schön und geschützt bleiben. Sie wird normalerweise nur einmal vor der Benutzung des Bodens ausgeführt.

Es wird empfohlen, die Erstreinigung nach 4-5 Tagen, spätestens aber nach 10 Tagen ab dem Verlegen und Verfugen der Oberfläche durchzuführen.

Die verfugte und gereinigte Oberfläche kann einen Zementschleier aufweisen, der aber leicht nur mit Wasser entfernt werden kann. Dafür ist ein Reinigungsmittel auf Säurebasis erforderlich, das je nach den Anweisungen des Herstellers entsprechend verdünnt (Verdünnung von 1:10 bis 1:4 mit kaltem Wasser). Zuerst muss die geffieste Fläche mit Wasser gespült werden, dies gilt vor allem für die Fugen (die normalerweise nicht säurebeständig sind). Verteilen Sie die vorbereitete säurehaltige Lösung auf der Oberfläche und lassen Sie diese kurz einwirken (2 Minuten). Lassen Sie das aufgebrachte Mittel nicht eintrocknen.

Entfernen Sie dann die Lösung mit einer Einbürstemaschine (nichtscheuernde Scheibe), einem Flüssigkeitssauger oder einem anderen Gerät, und/oder spülen Sie mit reichlich klarem Wasser nach. Es muss darauf hingewiesen werden, dass die maschinelle Reinigung einer Oberfläche (die besonders für strukturierte und große Oberflächen empfohlen wird) an den schwierig zu erreichenden Stellen stets eine manuelle Nachreinigung erforderlich macht, vor allem in den Ecken, entlang der Wände und in allen Bereichen, die von der Einbürstemaschine nicht erreicht werden. Es ist immer ratsam, die Haltbarkeit des Produktes gegen Säuren auf einer noch nicht verlegten Fliese oder in einem versteckten Bereich der bereits verfliesen Oberfläche zu testen, dies gilt insbesondere für gelappte oder polierte Fliesen. Die Verwendung von Reinigungsmitteln mit Flusssäure (HF) und seinen Derivate ist zu vermeiden.

### GEWÖHNLICHE REINIGUNG UND PFLEGE

Die gewöhnliche Reinigung der Oberflächen dient der Entfernung von Schmutz, Spuren und Abdrücken. Sie hat das Ziel, das ursprüngliche Aussehen wieder herzustellen.

Glasierete Feinsteinzeugfliesen benötigen keine Schutzbehandlung und die korrekte und systematische Reinigung ist ausreichend, um die Oberfläche dauerhaft schön zu halten.

Eine gründliche Reinigung sollte mit warmem Wasser, einem Lappen oder weichen Schwamm und eventuell mit neutralen Reinigungsmitteln erfolgen.

Für Räume mit großen Flächen können industrielle Reinigungsmaschinen verwendet werden, ggf. mit manueller Nachreinigung.

Empfehlungen:

- vermeiden Sie es, die Oberflächen mit Schleifmitteln, wie Scheuerschwämmen oder harten Bürsten zu reinigen, das kann zu Kratzern und Spuren führen, die sich nicht mehr entfernen lassen;
- entfernen Sie eventuell verbleibende Fett- oder Ölrückstände mit Reinigungsmitteln, die organische Lösemittel enthalten, oder alkalischen Reinigungsmitteln (pH> 9) und spülen Sie dann gründlich nach;
- Vermeiden Sie Seifen, da sie dazu neigen, eine schmierige Schicht zu hinterlassen, besonders wenn sie in Verbindung mit hartem Wasser verwendet werden;
- Verwenden Sie keine Produkte mit Wachs oder Glanzzusätzen;
- Vermeiden Sie Scheuermittel auf polierten oder glänzenden Oberflächen. Sie können auf jedoch matten Materialien verwendet werden, nachdem ein Test auf einem kleinen bereits verlegten Bereich erfolgt ist. Im Allgemeinen muss jedes nicht neutrale Reinigungsmittel zuerst auf einer nicht verlegten Fliese oder in einem verdeckten bereits verlegten Bereich getestet werden.

### HINWEISE ZUR VERLEGUNG VON RECHTECKFORMATEN ALS BODENBELAG

Für die Rechteckformate wird, neben der rechtwinkligen Verlegung, die fortlaufende Verlegung im regelmäßigen oder unregelmäßigen Verband mit dem folgenden Versatz empfohlen:

- Kantenverhältnis max. 4:1 für die Formate: 15x90 - 10x120 - 15x120 - 20x120 - 30x120 - 60x120 - 58x116 - 29x116 - 19,5x116 - 14,4x116
- Kantenverhältnis max. 3:1 für die Formate: 14,5x58 - 15x60 - 30x60 - 37,5x75 - 29x58 - 20x40

Ausführliche Informationen finden Sie auf [www.ragno.it](http://www.ragno.it)

### POSE

Avant de commencer les opérations de pose d'une surface quelle qu'elle soit, il est recommandé de veiller à ce que le matériau soit adapté et de quantité suffisante, que le ton et le calibre correspondent aux besoins. Il faudra ensuite se conformer à toutes les normes et prendre toutes les précautions qui sont à la base d'une bonne exécution du travail (préparation de la sous-couche, composition du mortier ou des colles, temps de séchage, mise en place des joints de dilatation, battage, etc....).

### POSE AVEC DES ADHÉSIFS

- La pose doit être effectuée par un personnel qualifié qui se servira d'outils appropriés.
- La surface sur laquelle la pose est effectuée (chape) doit être parfaitement plane. Valeur maximum conseillée : max 3 mm pour une dénivellation au-dessous d'une règle de 2 m.
- La surface sur laquelle le matériau est posé doit être à parfaite maturation, sans poussière ni fissurations visibles.
- Au cours de la pose, un bon éclairage est vivement conseillé.
- L'adhésif sera choisi en fonction de la typologie des carreaux (catégorie et format), du type de surface à revêtir et du domaine d'application auquel les carreaux sont destinés.
- Il convient de vérifier la manière dont le matériau est posé avant que l'adhésif ne soit sec, afin de pouvoir effectuer plus facilement des corrections si besoin est.

### POSE AVEC MORTIER FRAIS

La pose avec du mortier à base de ciment frais ou par "couche épaisse" est déconseillée pour des formats ayant un côté >30 cm et avec des supports non absorbants.

### RÉALISATION DES JOINTS

Les joints sont des éléments très importants pour qu'une surface carrelée se maintienne bien. C'est une phase pour laquelle il est conseillé de demander la collaboration et/ou les conseils d'un carreleur professionnel.

La responsabilité du fabricant ne pourra pas être mise en cause en cas de pose sans jointoiments. On appelle "pose à joint minimum" une pose avec un joint de 2 mm.

Les joints doivent être positionnés :

- sur des raccords structurels (joints structurels)
- entre sol et mur (joints périmétraux)
- entre deux carreaux (joints de pose ou jointoiment)
- entre des carreaux et d'autres matériaux (ex. juxtaposition céramique/lino/bois).

### JOINTOIEMENT DES SURFACES POSÉES

Avant de procéder au jointoiment, il est conseillé d'attendre que l'adhésif soit bien sec et de s'assurer que les joints de pose sont vides et libres de toute trace d'adhésif et/ou de poussières.

- Jointoyer le carrelage en procédant par petites surfaces (4-5 m<sup>2</sup>). Ce conseil doit surtout être suivi pour des produits structurés, antidérapants et polis.
- Éliminer le surplus de coulis de remplissage des joints de la surface en effectuant des mouvements en diagonale quand le produit est encore humide et enlever toutes les traces excédentaires, surtout pour les surfaces posées à l'extérieur.
- Nettoyer soigneusement avec une éponge imbibée d'eau claire et propre et repasser avec un chiffon humide sur toute la surface, joints compris.
- En présence de joints nettement contrastants avec la couleur des carreaux posés, il est conseillé de tester le coulis de remplissage des joints sur une petite surface dissimulée.
- Pour les joints époxy, il est recommandé de nettoyer à grande eau avec une éponge. La vitesse de réaction et de durcissement de ces produits empêche l'élimination des excédents après qu'ils ont durci. Le lendemain du jointoiment, effectuer un nettoyage complet avec un nettoyeur alcalin.
- Il est conseillé de consulter les fabricants de coulis de remplissage des joints pour vérifier si le choix effectué est correct par rapport au type de carreau.

### NETTOYAGE ET ENTRETIEN APRÈS LA POSE

Un chantier peut être considéré comme entièrement fini quand il est débarrassé de tous les outils et de tout le matériel ayant servi à sa réalisation. Pour réduire les risques d'endommager la surface carrelée, il est nécessaire de la protéger et d'éviter le plus possible la présence de matières abrasives (poussières ou résidus laissés par les travaux effectués successivement).

### NETTOYAGE INITIAL

Le lavage après la pose est une opération d'une extrême importance pour toutes les opérations qui s'ensuivront et pour pouvoir effectuer un entretien correct au quotidien.

Bien nettoyer le carrelage au départ permet aux sols de garder longtemps leur beauté et d'être protégés à long terme. Généralement, ce nettoyage est effectué une seule fois avant d'utiliser le sol.

Il est recommandé d'effectuer le nettoyage initial entre 4 et 5 jours (pas plus de 10) après la pose et le jointoiment.

La surface jointoyée et nettoyée peut présenter un film d'excédents cimentaires qui ne peut pas être éliminé à l'eau. Il est donc nécessaire d'utiliser un produit à base acide, correctement dilué (dilution de 1:10 à 1:4 dans l'eau froide), en fonction des conseils d'utilisation donnés par le fabricant.

La première opération à exécuter est de mouiller la surface carrelée et en particulier les joints (qui généralement ne résistent pas aux acides). Répandre la solution acide préparée et laisser agir environ 2 minutes. Ne pas laisser sécher le produit appliqué. Procéder à l'élimination de la solution avec une laveuse monobrosse (disque non abrasif), aspirateurs de liquides, autres appareils et/ou à la main. Rincer à grande eau à la fin.

Soulignons que le nettoyage effectué avec des appareils (particulièrement conseillé pour des produits structurés et pour de grandes surfaces), doit toujours être parachévé par une intervention manuelle aux endroits difficiles à atteindre, c'est-à-dire dans les coins, le long des murs et partout où la monobrosse ne peut pas arriver.

Il est toujours conseillé de vérifier la résistance du produit aux acides en les testant sur un carreau non posé ou sur un endroit peu en vue d'un carreau de la surface déjà posée, surtout pour les produits rodés ou polis. L'utilisation de nettoyeurs contenant de l'acide fluorhydrique (HF) et de ses dérivés doit être évitée.

### ENTRETIEN COURANT

Les opérations d'entretien courant des surfaces ont pour but d'éliminer la saleté, d'effacer les traces et de rendre au carrelage son aspect premier.

Les carreaux en grès cérame émaillé n'ont pas besoin d'être traités pour être protégés. Un nettoyage correct et systématique suffit à préserver la beauté de leur surface. Un nettoyage soigné doit être fait par un lavage normal avec de l'eau chaude, une serpillière/éponge douce et éventuellement avec un nettoyeur neutre. Pour les locaux recouverts de grandes surfaces, une machine industrielle lavante-séchante peut être utilisée. Finir par un lavage à la main là où cela s'avère nécessaire.

Recommandations :

- éviter de frotter les surfaces avec des instruments abrasifs tels que les pailles de fer ou les brosses dures, qui pourraient laisser des rayures et des traces indélébiles ;
- éliminer toute trace de graisse ou d'huile éventuellement présente au moyen de nettoyeurs contenant des solvants organiques, ou avec des nettoyeurs alcalins (pH>9) et terminer en rinçant soigneusement ;
- éviter d'utiliser des savons car ils ont tendance à laisser un film visqueux, surtout s'ils sont utilisés avec des eaux dures ;
- ne pas utiliser de produits contenant des cires ou des brillanteurs ;
- éviter d'utiliser des nettoyeurs décapants sur des surfaces lustrées et/ou polies ; ils peuvent être utilisés sur des matériaux mats, après les avoir testés sur un petit coin carrelé. En général, l'utilisation de tout nettoyeur non neutre doit être testée au préalable sur un carreau non posé ou sur une portion peu en vue du sol.

### CONSEILS DE POSE SUR SOLS POUR LES FORMATS RECTANGULAIRES

Pour les formats rectangulaires, outre une pose orthogonale, il est conseillé de procéder à une pose à l'anglaise régulière ou irrégulière, avec un décalage entre les pièces de :

- max 1/4 pour les formats : 15x90 - 10x120 - 15x120 - 20x120 - 30x120 - 60x120 - 58x116 - 29x116 - 19,5x116 - 14,4x116
- max 1/3 pour les formats : 14,5x58 - 15x60 - 30x60 - 37,5x75 - 29x58 - 20x40

Pour plus de renseignements, veuillez consulter le site [www.ragno.it](http://www.ragno.it)

ADVICE FOR LAYING AND MAINTENANCE **CONSIGLI DI POSA E MANUTENZIONE**  
verlegungs- und Pflegehinweise - conseils pour la pose et l'entretien  
consejos de colocación y mantenimiento - raccomandazioni по укладке и уходу EN

## COLOCACIÓN

Antes de iniciar las operaciones de colocación de cualquier superficie, se recomienda asegurarse de que la cantidad del lote de material sea suficiente y de que el tono y el calibre sean adecuados. Deberán seguirse luego todas las normas y precauciones para una correcta ejecución del trabajo (preparación de la base, composición del mortero o de los adhesivos, respeto de los tiempos de secado, posición de las juntas de dilatación, golpeado, etc...).

## COLOCACIÓN CON ADHESIVOS

- La colocación ha de ser efectuada por personal cualificado con la ayuda de herramientas adecuadas.
- La superficie sobre la que se efectúe la colocación (placa) ha de ser totalmente plana. Valor máximo aconsejado no superior a 3 mm para un desnivel determinado bajo una regla de 2 m.
- La superficie sobre la que se efectúe la colocación deberá estar bien seca, sin polvo ni fisuraciones visibles.
- Es importante utilizar una iluminación adecuada durante la operación de colocación.
- La elección del adhesivo dependerá del tipo de baldosa (grupo de pertenencia y formato), del tipo de superficie a recubrir y del uso previsto.
- Conviene comprobar la colocación del material antes de que el adhesivo esté seco, con el fin de facilitar posibles correcciones.

## COLOCACIÓN CON MORTERO FRESCO

La colocación con mortero de cemento fresco o "capa gruesa" está aconsejada para formatos con lado > 30 cm y con soportes no absorbentes.

## REALIZACIÓN DE LAS JUNTAS

Las juntas son elementos muy importantes para el mantenimiento de una buena superficie embaldosada; se aconseja servirse de la colaboración y/o del asesoramiento de un solador profesional. Se declina toda responsabilidad por la colocación sin juntas; se considera colocación de "junta mínima" la efectuada con una junta de 2 mm.

Las juntas deberán estar posicionadas:

- en uniones estructurales (juntas estructurales)
- entre el suelo y la pared (juntas perimetrales)
- entre una baldosa y otra (juntas de colocación o juntas)
- entre baldosas y otros materiales (por ej. combinación de cerámica / linóleo / madera)

## REJUNTADO DE LA SUPERFICIE EMBALDOSADA

Antes de realizar las juntas, es aconsejable esperar a que el adhesivo esté completamente seco y asegurarse de que las juntas de colocación estén vacías y libres de todo rastro de adhesivo y/o polvo.

- Efectuar el rejuntado de pequeñas superficies cada vez (4-5 m<sup>2</sup>). Ello deberá tenerse en cuenta sobre todo para productos estructurados, antideslizantes y pulidos.
- Eliminar de la superficie el material de rejuntado en exceso efectuando movimientos diagonales cuando el producto todavía está húmedo y quitar todos los residuos, especialmente para las superficies de exterior.
- Limpiar cuidadosamente con una esponja mojada en agua limpia y repasar con un paño húmedo por toda la superficie, incluidas las juntas.
- Para juntas cuyo color contraste fuertemente con el de las baldosas colocadas, se aconseja probar el material de rejuntado en una zona limitada y escondida.
- Para los rellenos de juntas epoxi, se recomienda limpiar con una esponja y agua abundante. La velocidad de reacción y endurecimiento de estos productos impide poder quitar los residuos después del endurecimiento. Efectuar una limpieza completa con detergente alcalino al día siguiente de haber realizado el rejuntado.
- Se aconseja consultar a los fabricantes del material de rejuntado para comprobar si elección de la junta es correcta para el tipo de baldosa.

## LIMPIEZA Y MANTENIMIENTO DESPUÉS DE LA COLOCACIÓN

Una obra puede considerarse completamente acabada cuando está libre de todas las herramientas y de todos los materiales derivados de los trabajos llevados a cabo. Para impedir que se dañe la superficie embaldosada, es necesario protegerla y evitar lo más posible la presencia de materiales abrasivos (polvo o residuos de trabajos sucesivos).

## LIMPIEZA INICIAL

La limpieza después de la colocación es una fase de fundamental importancia para todas las intervenciones sucesivas y para un correcto mantenimiento. Una cuidadosa limpieza inicial permitirá que los pavimentos permanezcan bonitos y protegidos durante largo tiempo; suele efectuarse una sola vez antes de la utilización del pavimento.

Se recomienda efectuar la limpieza inicial después de 4-5 días, y no más tarde de 10, de la colocación y del rejuntado de la superficie.

La superficie con las juntas y limpia puede presentar una película de residuo de cemento que no es posible quitar sólo con agua, siendo necesaria la utilización de un producto de base ácida, oportunamente diluido (dilución de 1:10 a 1:4 en agua fría), según lo declarado por el fabricante.

La primera operación a efectuar es mojar la superficie embaldosada y en particular las juntas (normalmente no resistentes a los ácidos). Esparcir la solución ácida preparada y dejar actuar durante breve tiempo (2 min.). No dejar secar el producto aplicado.

Remover la solución con la ayuda de una máquina monocepillo (con disco no abrasivo), un aspirador de líquidos, otros medios y/o de forma manual y aclarar con agua abundante al final. Es importante subrayar que la limpieza efectuada con máquinas (especialmente aconsejada para productos estructurados y para grandes superficies) ha de completarse siempre de forma manual en aquellos puntos difíciles de alcanzar, sobre todo en los rincones, en las paredes de los locales y en todas aquellas zonas en las que la máquina monocepillo no puede operar.

Es aconsejable siempre probar la resistencia del producto a los ácidos en una baldosa sin colocar o sobre una pequeña porción escondida de la superficie embaldosada, sobre todo para productos lapeados o pulidos. Evitar el uso de productos de limpieza que contengan ácido fluorhídrico (HF) y sus derivados.

## LIMPIEZA ORDINARIA

Las operaciones de limpieza ordinaria de las superficies tienen la finalidad de eliminar la suciedad, borrar las señales y restablecer el aspecto original.

Las baldosas de gres porcelánico esmaltado no necesitan tratamientos de protección; una correcta y sistemática limpieza es suficiente para mantener inalterada la superficie.

Para una cuidadosa limpieza deberá efectuarse un fregado normal con agua caliente, paño/esponja suave y, si es necesario, con la utilización de detergentes neutros. En los locales con grandes superficies podrán utilizarse máquinas industriales fregadoras-secadoras, completando la limpieza de manera manual donde sea necesario.

Recomendaciones:

- no restregar las superficies con instrumentos abrasivos, como estropajos de metal o cepillos duros, que pudieran dejar arañazos y señales indelebles;
- quitar los posibles residuos oleosos o de grasas con detergentes que contengan disolventes orgánicos o con detergentes alcalinos (pH>9) y efectuar un cuidadoso aclarado;
- evitar la utilización de jabones, pues tienden a dejar una capa viscosa, sobre todo si se utilizan con aguas duras;
- no utilizar productos que contengan ceras o agentes de abrillantado;
- evitar el uso de detergentes abrasivos sobre superficies brillantes y/o pulidas; pueden utilizarse sobre materiales mates, pero controlando previamente sobre una pequeña porción embaldosada. El uso de cualquier detergente no neutro deberá ser probado previamente sobre una baldosa sin colocar o sobre una porción escondida del pavimento.

## CONSEJOS PARA LA PAVIMENTACIÓN CON FORMATOS RECTANGULARES

En lo que concierne a los formatos rectangulares, además de la colocación ortogonal, se aconseja el solado corrido regular o irregular con un escalonamiento recomendado entre pieza y pieza de:

- como máximo 1/4 en los formatos de: 15x90 - 10x120 - 15x120 - 20x120 - 30x120 - 60x120 - 58x116 - 29x116 - 19,5x116 - 14,4x116
- como máximo 1/3 en los formatos de: 14,5x58 - 15x60 - 30x60 - 37,5x75 - 29x58 - 20x40

Para mayor información, consulte el sitio web [www.ragno.it](http://www.ragno.it)

## UKLADKA

Перед началом работ по укладке на любой поверхности рекомендуем убедиться в том, что имеющийся материал соответствует требованиям по количеству, тону и калибру. Далее следует соблюдать все правила и меры предосторожности, которые лежат в основе правильного выполнения работ (подготовка подстилающего слоя, состав раствора или клея, соблюдение сроков высыхания, расположение расширительных швов, трамбовка и т.д.).

## UKLADKA С ПРИМЕНЕНИЕМ КЛЕЯЩИХ СОСТАВОВ

- Укладка должна производиться квалифицированным персоналом с помощью соответствующих инструментов.
- Поверхность, на которую производится укладка (цементная стяжка), должна быть абсолютно ровной. Максимально допустимый перепад уровня не должен превышать 3 мм при измерении линейкой длиной 2 м.
- Поверхность, на которую производится укладка, должна быть хорошо выдержанной, очищенной от пыли и без видимых трещин.
- Во время выполнения укладки настоятельно рекомендуем использовать соответствующее освещение.
- Выбор клеящего состава зависит от типа плитки (группа принадлежности и формат), типа покрываемой поверхности и ее назначения.
- Для устранения возможных дефектов следует проверять укладку материала, прежде чем клеящий состав высохнет.

## Укладка с применением свежего цементного раствора

Для форматов со стороной более 30 см не рекомендуется укладка с применением свежего цементного раствора или на «толстый слой» при неабсорбирующей подстилающей основе.

## Выполнение швов

Швы являются важнейшим элементом для поддержания поверхности, облицованной плиткой, в хорошем состоянии, именно поэтому мы рекомендуем привлекать к сотрудничеству и/или консультацию профессионального укладчика. Отклоняется любая ответственность в случае укладки без швов; минимальным швом считается зазор 2 мм.

Швы должны присутствовать:

- на конструктивных соединениях (конструктивные швы)
- между полом и стеной (периметральные швы)
- между плитками (укладочные швы)
- между плитками и другими материалами (например, сочленение керамики/линолеума/дерева).

## Затирка швов на уложенной поверхности

Перед началом затирки швов рекомендуется выждать до полного высыхания клея и убедиться в том, что укладочные швы чистые и не содержат остатков клея и/или пыли.

- Швы следует заделывать по частям небольшими поверхностями (4-5 кв.м). Это особенно важно учитывать при укладке структурной, нескользящей и полированной плитки.
- Удалите с поверхности избыток затирочного материала диагональными движениями, пока затирка влажная, и уберите все излишки, особенно с наружных поверхностей.
- Аккуратно промойте губкой, смоченной в чистой прозрачной воде, и протрите всю поверхность, включая швы, влажной тряпкой.
- Для швов, контрастных по цвету с уложенной плиткой, рекомендуется протестировать затирку на ограниченном скрытом участке поверхности.
- Для эпоксидных затирок рекомендуется очистка с помощью обильно смоченной водой губки. Скорость реакции и затверждение этих продуктов делает невозможным их удаление после затверждения. На следующий день после затирки швов следует выполнить полную уборку с применением щелочного моющего средства.
- Рекомендуется проконсультироваться у производителей затирочного материала, чтобы убедиться в правильном его выборе относительно типа плитки.

## Уборка и уход после укладки

Строительство можно считать законченным, когда его площадка полностью расчищена от любого материала/инструментария, использованных во время работ. Для снижения рисков повреждения поверхности, покрытой плиткой, необходимо предохранять ее и не допускать присутствия каких-либо абразивных материалов (пыль или остатки затирочных материалов).

## Начальная уборка

Промывание после укладки имеет исключительно важное значение для всех последующих действий и для правильного ухода за поверхностью.

Тщательная начальная промывка обеспечивает полам хороший внешний вид и длительную защищенность, обычно она выполняется однократно перед началом эксплуатации полов. Начальную промывку рекомендуется выполнять по истечении 4-5 дней и не позднее 10 дней после затирки швов.

На очищенной поверхности с заделанными швами может появиться пленка из цементного осадка, которая не удаляется только водой; в этом случае необходимо применение моющего средства с кислотной основой, правильно разведенного в воде (разбавление в холодной воде в пропорции от 1:10 до 1:4) в соответствии с указаниями производителя.

Первое, что необходимо выполнить, это смочить водой покрытую плиткой поверхность и, особенно, швы (как правило, нестойкие к воздействию кислот). Затем нанесите приготовленный кислотный раствор и оставьте действовать на короткое время (2 мин.). Не допускайте высыхания нанесенного продукта. Далее приступайте к удалению раствора с помощью поломочной машины (с неабразивным диском), водным пылесосом, другими средствами и/или вручную и в конце следует обильное промывание. Важно подчеркнуть, что очистка, выполненная с помощью машин (особенно рекомендуемая для структурной продукции и больших поверхностей), должна обязательно завершаться ручной уборкой труднодоступных мест, особенно, в углах, вдоль стен внутри помещения и во всех местах, куда щетка не может добраться). Рекомендуется всегда протестировать устойчивость материала к воздействию кислот на неукладочной плитке или на маленьком скрытом участке, покрытом плиткой; это особенно важно для полуполированной и полированной плитки. Следует избегать применения мощных средств, содержащих плавиковую кислоту (HF) и ее производные.

## Регулярная уборка

Регулярная уборка поверхности производится для удаления грязи, следов и для восстановления изначального внешнего вида. Плитка из глазурованного керамогранита не нуждается в защитной обработке, для поддержания поверхности в неизменном виде достаточно правильно и систематически производить ее уборку. Тщательная уборка должна производиться путем обычного промывания теплой водой, тряпкой/мягкой губкой, при необходимости, с применением нейтральных моющих средств. Для помещений с большими поверхностями можно использовать промышленные поломочные машины, дополняя, где необходимо, ручной промывкой. Рекомендации:

- не допускать натирания поверхностей абразивными материалами, как например, губки из металлической стружки или жесткие щетки, которые могут оставить царапины и несмываемые следы;
- удалить возможные жирные или масляные пятна с помощью моющих средств, содержащих органические растворители, или с помощью щелочных моющих средств (pH>9), после чего тщательно прополоскать.
- не применять мыло, так как после него образуется липкая пленка, особенно если используется жесткая вода;
- не применять продукты, содержащие воск или придающие блеск вещества;
- не применять абразивные моющие средства на блестящих и/или полированных поверхностях; они могут использоваться на матовых материалах, однако, предварительно их следует протестировать на маленьком участке плиточной поверхности. В целом, использование любого не нейтрального моющего средства, должно быть предварительно опробовано на неукладочной плитке или на скрытом участке пола.

## РЕКОМЕНДАЦИИ ПО НАПОЛЬНОЙ UKLADKE ПРЯМОУГОЛЬНЫХ ФОРМАТОВ

Помимо ортогональной укладки, для прямоугольных форматов рекомендуется укладка с равномерным или неравномерным разгоном между двумя соседними элементами, равным:

- макс. 1/4 для форматов: 15x90 - 10x120 - 15x120 - 20x120 - 30x120 - 60x120 - 58x116 - 29x116 - 19,5x116 - 14,4x116
- макс. 1/3 для форматов: 14,5x58 - 15x60 - 30x60 - 37,5x75 - 29x58 - 20x40

Более подробную информацию см. на сайте [www.ragno.it](http://www.ragno.it)



TREATMENT PROCEDURES **NORME DI TRATTAMENTO**

behandlungshinweise - normes de traitement - normas de tratamiento - правила промывки

GRES FINE PORCELLANATO: TIPO NATURALE; TIPO LEVIGATO FINE PORCELAIN STONEWARE: MATT TYPE; POLISHED TYPE FEINSTEINZEUG: MATTE FLIESE; POLIERTE FLIESE	GRES CERAME FIN: TYPE BRUT; TYPE POLI GRES FINO PORCELÁNICO: TIPO MATE; TIPO PULIDO КЕРАМОГРАНИТ: НАТУРАЛЬНЫЙ, ПОЛИРОВАННЫЙ	MACCHINE MACHINES GERÄTE MACHINES MÁQUINAS МАШИНЫ
LAVAGGIO CLEANING REINIGUNG NETTOYAGE LAVADO МОЙКА	Lavaggio di fondo e risciacquo - Tipo naturale Thorough washing and rinsing - Matt type Gründliche Reinigung und Abspülen - Matte Fliese Nettoyage à fond et rinçage - Type brut Fregado a fondo y enjuague - Tipo mate Тщательная мойка и промывка - Натуральный тип	Monospazzola / Aspiraliquidi Single-brush machine / Wet vacuum Einbürstenmaschine / Nasssauger Mono-brosse / Aspirateur à eau Máquina fregadora / Aspiradora de líquidos Однощеточная машина со сбором жидкостей
TRATTAMENTO TREATMENT BEHANDLUNG TRAITEMENT TRATAMIENTO ОБРАБОТКА	Impregnazione - Tipo levigato Impregnation - Polished type Imprägnierung - Polierte Fliese Imprégnation - Type poli Impregnación - Tipo pulido Плитка - Полированный тип	
MANUTENZIONE MAINTENANCE PFLEGE ENTRETIEN MANTENIMIENTO УХОД	Pulizia ordinaria - Tipo naturale e levigato Routine cleaning - Matt and polished type Normale Reinigung - Matte und polierte Fliese Nettoyage ordinaire - Type brut et poli Limpieza ordinaria - Tipo mate y pulido Обычный уход - Натуральный и полированный тип  Pulizia straordinaria - Tipo naturale Special cleaning - Matt type Sonderreinigung - Matte Fliese Nettoyage extraordinaire - Type brut Limpieza extraordinaria - Tipo mate Экстренный уход - Натуральный тип  Smacchiatura - Tipo levigato Stain removal - Polished type Fleckenentfernung - Polierte Fliese Elimination des taches - Type poli Eliminación manchas - Tipo pulido Выведение пятен - Полированный тип	Lava-asciuga Scrubber-dryer Bodenreinigungs-maschine Laveuse-sècheuse Fregadora-secadora Машина для мойки и сушки пола  Monospazzola / Aspiraliquidi Single-brush machine / Wet vacuum Einbürstenmaschine / Nasssauger Mono-brosse / Aspirateur à eau Máquina fregadora / Aspiradora de líquidos Однощеточная машина со сбором жидкостей

GRES FINE PORCELLANATO: TIPO NATURALE; TIPO LEVIGATO FINE PORCELAIN STONEWARE: MATT TYPE; POLISHED TYPE FEINSTEINZEUG: MATTE FLIESE; POLIERTE FLIESE	GRES CERAME FIN: TYPE BRUT; TYPE POLI GRES FINO PORCELÁNICO: TIPO MATE; TIPO PULIDO КЕРАМОГРАНИТ: НАТУРАЛЬНЫЙ, ПОЛИРОВАННЫЙ	ATTREZZI EQUIPMENT WERKZEUGE OUTLIS ÚTILES ОУСТАТКА	PRODOTTO * PRODUCT* PRODUKT* PRODUIT* PRODUCTO*	NOTE NOTES BEMERKUNGEN NOTES NOTAS ПРИМЕЧАНИЯ
Disco morbido Soft disk Weiche Scheibe Disque doux Disco blando Мягкий диск	Disincrostante acido Acid-based scale remover Säurehaltiger Entkalker Détartrant acide Desincrustante ácido Кислотный очиститель отложений			Diluire come da indicazioni sull'etichetta, stendere la soluzione. Lavare, aspirare. Risciacquare, aspirare. Dilute as per instructions on the label. Spread the solution. Wash, vacuum. Rinse, vacuum. Gemäß den Angaben auf dem Aufkleber verdünnen, die Lösung auftragen. Waschen, absaugen. Abspülen, absaugen. Diluer selon les indications sur l'étiquette, étaler la solution. Laver, aspirer. Rincer, aspirer. Diluir siguiendo las indicaciones de la etiqueta. Aplicar la solución. Fregar, aspirar. Enjuagar, aspirar. Разбавить согласно указаниям на этикетке, нанести раствор на поверхность. Промыть, собрать. Ополоснуть, собрать.
Pennellessa Flat brush Flachpinsel Brocha plana Большая кисть	Impermeabilizzante Waterproofing product Abdichtendes Mittel Imperméabilisant Impermeabilizante Герметик			Rimuovere il residuo secco dopo 24 ore con monospazzola o disco morbido. Remove the dry residue after 24 hours with a single-brush machine and soft disk. Das überschüssige, getrocknete Produkt nach 24 Stunden mit einem Einbürstengerät mit weicher Scheibe entfernen. Enlever le résidu sec au bout de 24 heures avec une machine mono-brosse et disque doux. Remover el residuo seco transcurridas 24 horas con máquina fregadora y disco blando. Удалить сухой остаток через 24 часа с помощью однощеточной машины с мягким диском
Scopa - Straccio Broom - Rag Besen - Tuch Balai - Serpillère Escoba - Trapo/fregona Щетка, тряпка	Detergente per pavimenti ceramici Detergent for ceramic floors Reinigungsmittel für keramische Böden Détergent pour sols céramiques Detergente para pavimentos cerámicos Моющее средство для керамических полов			Per la pulizia di tutti i giorni; per rimuovere lo sporco di passaggio For daily cleaning; for removing dirt from traffic. Pour le nettoyage de tous les jours; pour éliminer la saleté due au passage. Für die tägliche Reinigung; um den durch Begehung entstandenen Schmutz zu entfernen. Para la limpieza diaria; para eliminar la suciedad provocada por el paso. Для ежедневной уборки; для удаления грязи от хождения.
Straccio Rag Tuch Serpillère Trapo/fregona Тряпка	Lavapavimenti forte Strong floor detergent Starkes Bodenreinigungs-mittel Détergent puissant pour sols Fregasuelos fuerte Сильнодействующее средство для мытья полов			Diluire come da indicazioni sull'etichetta Dilute as per instructions on the label Gemäß den Angaben auf dem Aufkleber verdünnen Diluer selon les indications sur l'étiquette Diluir siguiendo las indicaciones de la etiqueta Растворить согласно указаниям на этикетке
	Detergente smacchiatore Detergent-stain remover Reiniger/Fleckenentferner Détergent détachant Detergente quitamanchas Пятновыводящее моющее средство			Versare il prodotto puro sulla macchia e sull'intera mattonella, lasciare asciugare, risciacquare. Apply the product on the stain and the entire affected tile, without diluting, leave to dry, rinse. Das unverdünnte Produkt auf den Fleck und die gesamte Fliese auftragen, trocknen lassen, abspülen. Verser le produit pur sur la tache et sur tout le carreau. Laisser sécher, rincer. Verter el producto puro sobre la mancha y sobre todo el azulejo, dejar secar, enjuagar. Налить на пятно и на всю поверхность плитки чистый раствор, высушить, промыть.

\* Produttori consigliati / Producers recommended / Empfohlene Hersteller / Fabricants recommandés / Fabricantes aconsejados / Рекомендуемые производители:

BONASYSTEMS ITALIA S.r.l. info@bonasystemsitalia.it www.bonasystemsitalia.it  
 FILA S.p.A. fila@filachim.it www.filachim.com  
 FABER CHIMICA s.r.l. info@faberchimica.com www.faberchimica.com  
 GEAL-CHIM s.r.l. info@geal-chim.it www.geal-chim.it

L'Azienda si riserva la facoltà di modificare in qualunque momento le informazioni e le caratteristiche tecniche illustrate nel presente catalogo, che non sono comunque da ritenersi legalmente vincolanti. Pesì, colori e misure possono subire variazioni tipiche del particolare processo di cottura del materiale ceramico. I colori e le caratteristiche estetiche dei prodotti sono quanto più possibile vicini a quelli reali, nei limiti consentiti dai processi di stampa.

The Company reserves the right, at any time and without prior notice, to change the information and technical characteristics given in this catalogue, none of which are to be considered legally binding. Weights, colours and dimensions are subject to the normal variations resulting from the ceramic firing process. Within the limits of printed material, the colours and aesthetic features of the products illustrated correspond as closely as possible to those of the actual products.

Die Firma behält sich das Recht vor, die in diesem Katalog enthaltenen, unverbindlichen Angaben und technischen Eigenschaften jederzeit zu verändern. Gewichte, Farben und Abmessungen können infolge des besonderen Brennverfahrens des Keramikmaterials variieren. Die Abbildungen der Farben und die ästhetischen Merkmale entsprechen nach Möglichkeit und innerhalb der durch die Drucktechnik gesetzten Grenzen den Produkten.

L'entreprise se réserve le droit de modifier à tout moment les informations et les caractéristiques figurant dans ce catalogue lesquelles ne sauraient en tout état de cause engager juridiquement l'entreprise. Les poids, les coloris et les dimensions peuvent subir des variations, dues au processus de cuisson particulier du matériau céramique. Les coloris et les caractéristiques esthétiques des produits sont présentés de la façon la plus réaliste possible, dans les limites permises par les processus d'impression.

La empresa se reserva el derecho de modificar en cualquier momento las informaciones y las características técnicas ilustradas en el presente catálogo que no se deben considerar, de todos modos, jurídicamente vinculantes. Los valores del peso, los colores y las medidas pueden sufrir variaciones típicas del particular proceso de cocción del material cerámico. Los colores y las características estéticas de los productos ilustrados se parecen en la manera de lo posible a los originales, considerando las limitaciones del proceso de impresión.

Компания оставляет за собой право изменить в любой момент приведенные в данном каталоге сведения и технические характеристики, которые не должны считаться легально обязательными. Вес, цвета и размеры могут претерпеть изменения, свойственные особенному процессу обжига керамических материалов. Цвета и эстетические характеристики продукции максимально приближены к реальности, в степени, допустимой возможностями печати.

Print: 01.20

